



PANEL FASTENERS

Fastenings for Panels in the Groove  
Fastenings for Panels on the Groove

Panel fasteners  
Products in this section

5



**Cover Profiles PP**

- Ideal for covering grooves or fixing panels
- Available in several colours

165



**Lip Seals**

- Durable elastic hold for panel elements
- Cover edges to prevent dirt and dampness getting in

167



**Multiblocks PA**

- Variable thanks to two contact faces and height adjuster
- Screw attachment ensures a firm hold

169

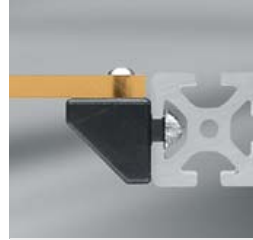

**Multiblocks Zn**

- Exceptionally stable fasteners
- Easy adjustment for material thickness

172



**Safety Fastening Set Multiblock 8**

- The captive panel fastener
- For use with Multiblock 8 PA and 8 Zn

173



**Multi Bracket 12 Zn**

- For fastening panel elements to Profiles 12
- Simple adjustment to the height of the element

174



**Quick Multiblocks**

- Prevent inadvertent opening of fixings
- Secure panel fastening – cannot be released without being destroyed

176



**Clamp Multiblocks PA**

- For fastening panels on the groove without the need for machining
- Flexible locating lug securely holds panels of different thicknesses

178



**Panel-Clamping Strips**

- Retrofit panels in closed frames
- Holds all types of panels on the groove

180



**Double Panel Profiles**

- For building double-walled frame elements
- Straightforward assembly

182



**Rebate Profiles Al**

- Flexible panel fastening anchored in the groove
- Also suitable as a rebate strip for doors

185



**Panel/Glass Clamp**

- Fasten panel elements without needing to machine them
- Continuous air gap between frame and panel

188

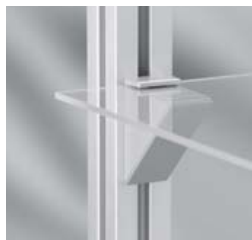

**Support Arm X 6-8**

- Shelf support with clamping system for the panel element
- Clean, elegant design

190



**Table-Top Fastening Set**

- Secure table tops to profile frames
- Self-tapping screws for all types of wooden panels

191



**Flange**

- Mounting plate for table columns
- Used with Column Profile D110

192



## Cover Profiles PP

The multi-purpose solution

- Ideal for covering grooves or fixing panels
- Available in several colours
- Also ESD-safe



5

Cover Profile can be used as a cover for the profile groove or as a panel-fixing profile for panel elements.

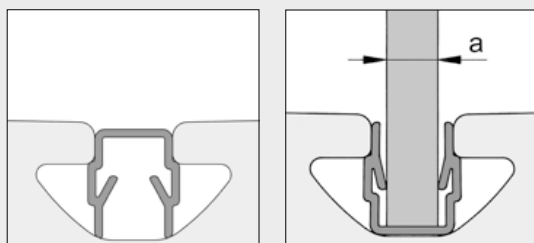

Cover Profile	a [mm]
5	1.5-2.0
6	2.0-3.5
8 (ESD)	4.0-5.5
10 (ESD)	4.0-8.0
12	6.0-9.5

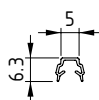

### Cover Profile 5



PP/TPE  
m = 13.5 g/m

natural, 1 pce., length 2000 mm	0.0.391.73
black, 1 pce., length 2000 mm	0.0.391.74
grey similar to RAL 7042, 1 pce., length 2000 mm	0.0.639.02

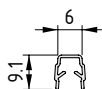

### Cover Profile 6



PP/TPE  
m = 20.4 g/m

natural, 1 pce., length 2000 mm	0.0.419.48
black, 1 pce., length 2000 mm	0.0.431.01



### Cover Profile 8



PP/TPE  
m = 26 g/m

natural, 1 pce., length 2000 mm	0.0.422.23
black, 1 pce., length 2000 mm	0.0.422.26
green, similar to RAL 6016, 1 pce., length 2000 mm	0.0.489.44
red, similar to RAL 3003, 1 pce., length 2000 mm	0.0.489.46
yellow, similar to RAL 1018, 1 pce., length 2000 mm	0.0.489.43
blue, similar to RAL 5010, 1 pce., length 2000 mm	0.0.481.01
grey similar to RAL 7042, 1 pce., length 2000 mm	0.0.489.45



### Cover Profile 8 ESD



PP/TPE  
m = 26 g/m

black, 1 pce., length 2000 mm	0.0.617.80
-------------------------------	------------

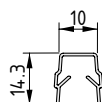

### Cover Profile 10



PP/TPE  
m = 31.5 g/m

natural, 1 pce., length 2000 mm

0.0.632.10

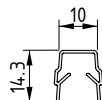

### Cover Profile 10 ESD



PP/TPE  
m = 31.5 g/m

black, 1 pce., length 2000 mm

0.0.632.04

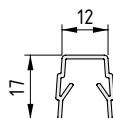

### Cover Profile 12



PP/TPE  
m = 58 g/m

natural, 1 pce., length 2000 mm

0.0.005.08

black, 1 pce., length 2000 mm

0.0.005.28

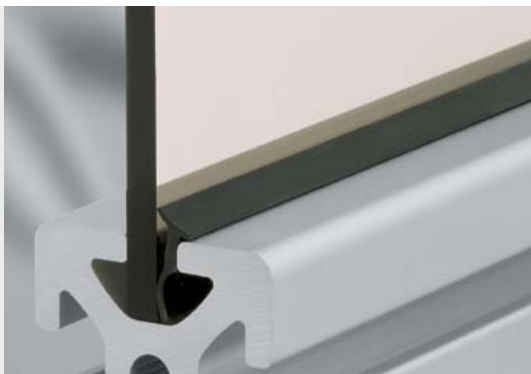

## Lip Seals

Long-term elasticity and resistance

- Fix panel elements in the groove
- Neatly cover over edges
- Resistant to cleaning agents

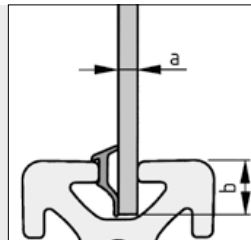
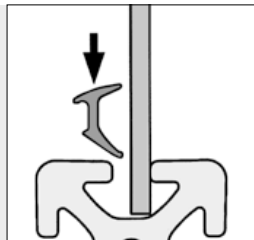

The Assembly Tool facilitates the process of pressing the Lip Seal into the profile groove in the right orientation.

Assembly Tool Lip Seal 587

The Lip Seals are best wetted with soapy water prior to assembly to ensure they are fitted easily and correctly. Careful pressure must be applied to lock them into the profile groove.

Lip Seal	a [mm]	b [mm]
5 2-3	2-3	5.3
6 2-4	2-4	8.7
8 2-4	2-4	11.2
8 4-6	4-6	11.2
12 6-8	6-8	17.3

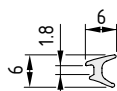

### Lip Seal 5 2-3mm

TPE  
m = 13 g/m

black, 1 roll length 20 m

0.0.437.12

grey, similar to RAL 7040, 1 roll length 20 m

0.0.484.39

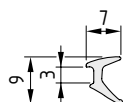

### Lip Seal 6 2-4mm

TPE  
m = 20 g/m

black, 1 roll length 20 m

0.0.439.20

grey, similar to RAL 7040, 1 roll length 20 m

0.0.491.08

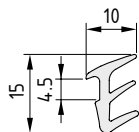

### Lip Seal 8 2-4mm

TPE  
m = 52 g/m

black, 1 roll length 20 m

0.0.436.85

grey, similar to RAL 7040, 1 roll length 20 m

0.0.489.91

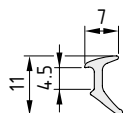

### Lip Seal 8 4-6mm

TPE  
m = 26 g/m

black, 1 roll length 20 m

0.0.436.88

grey, similar to RAL 7040, 1 roll length 20 m

0.0.489.94

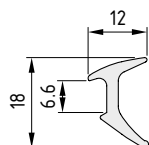

### Lip Seal 12 6-8mm

TPE  
m = 58 g/m

black, 1 roll length 20 m

0.0.005.33

grey, similar to RAL 7040, 1 roll length 20 m

0.0.005.37



## Double-Lip Seal 8 4-6mm

- For panels made from plastic or safety glass
- Prevent direct contact with the aluminium profile
- Absorb vibrations and seal the groove



Double-Lip Seal 8 is used for fitting panel elements directly into grooves of Profiles 8. It provides a sealing function and prevents direct contact with the aluminium profile. Double-Lip Seal 8 completely encloses panel elements of thickness 4 to 6 mm in the profile groove.

Double-Lip Seal 8 4-6mm is ideal for all types of panel elements – including those made of plastic or safety glass.

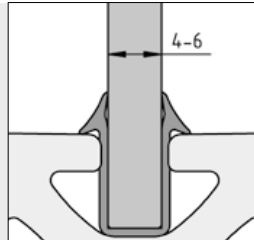

N.B.: Double-Lip Seal 8 is best installed using soapy water. It is then slipped onto the panel element and pushed into the profile groove. The profile frame is assembled around the panel element.

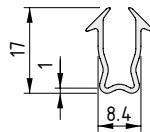

### Double-Lip Seal 8 4-6mm



TPE

m = 50 g/m

black, 1 roll length 20 m

0.0.495.08

grey similar to RAL 7042, 1 roll length 20 m

0.0.611.40



## Multiblocks PA

- Variable thanks to two contact faces and height adjuster
- Screw attachment ensures a firm hold for panel elements
- One fastening – four positions



5



Multiblock PA is inserted into the profile groove at any position. Light cladding panels and panel elements made from Acrylic Glass, Plastic or Compound Material must be provided with a bore at the appropriate location and screwed to the Multiblock.

Multiblock PA has two mounting locations plus a height adjuster which combine to give four offset positions from the edge of the profile. This allows different distances to be set to the edge of the profile so that panel elements of varying thicknesses can be screwed on flush.

The panels are secured by screw connection with the square nut inserted in the Multiblock. This nut can be moved within a slot, a fact that allows a considerable degree of tolerance for the position of the bores in the panel element.

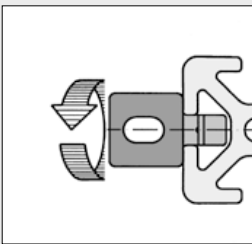

Twisting the Multiblock PA into the profile groove. The Multiblocks can be moved within the groove in order to align them with the bore in the panel element.

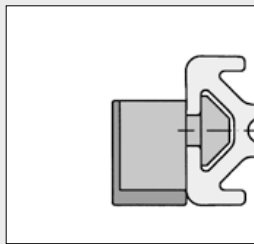

The contact face can be varied thanks to two different mounting orientations and the movable height adjuster.

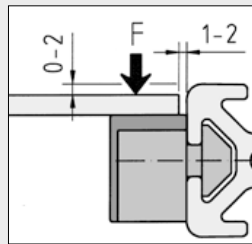

Recommendation for mounting the panel element and permissible loading forces for Multiblocks PA.

Multiblock	F [N]
5 PA	100
6 PA	150
8 PA	250
10 PA	400

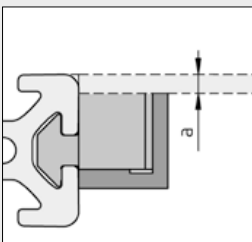

Possible offset distances between the mounting locations and the edge of the profile.

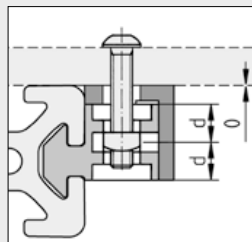
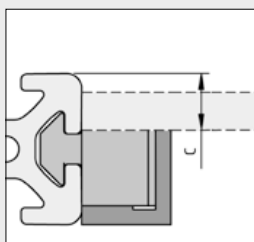
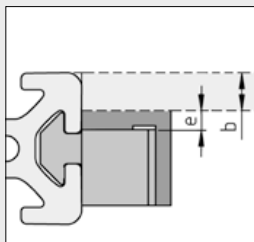

The length of the fastening screw depends on the thickness of the panel element and use of the height adjuster.

Multiblock	5 PA	6 PA	8 PA	10 PA
a [mm]	2	3	5	5
b [mm]	4	6	10	10
c [mm]	6	9	15	15
d [mm]	8	9	10	15
e [mm]	2	3	5	5

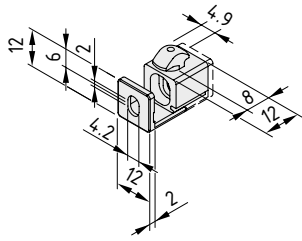

### Multiblock 5 PA



Basic unit and height adjuster, PA-GF  
 Square nut DIN 562-M4, St, bright zinc-plated  
 m = 2.0 g

black, 1 pce.	0.0.370.71
grey, 1 pce.	0.0.641.58

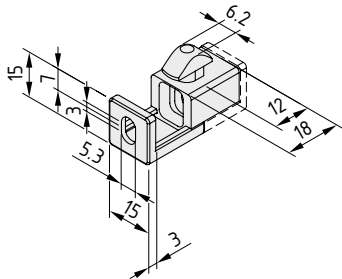

### Multiblock 6 PA



Basic unit and height adjuster, PA-GF  
 Square nut DIN 557-M5, St, bright zinc-plated  
 m = 6.0 g

black, 1 pce.	0.0.419.58
grey, 1 pce.	0.0.635.68

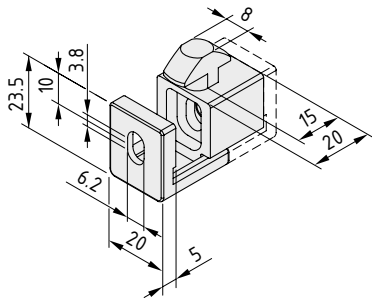

### Multiblock 8 PA



Basic unit and height adjuster, PA-GF  
 Square nut DIN 557-M6, St, bright zinc-plated  
 Spring clip, St, bright zinc-plated  
 m = 14.0 g

black, 1 pce.	0.0.026.72
grey, 1 pce.	0.0.630.28

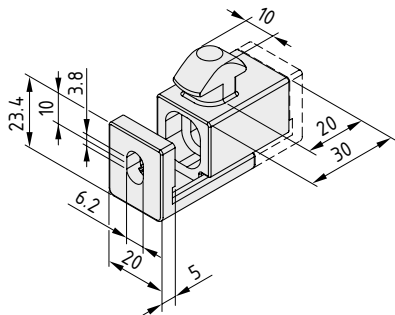

### Multiblock 10 PA



Basic unit and height adjuster, PA-GF  
 Square nut DIN 557-M6, St, bright zinc-plated  
 Spring clip, St, bright zinc-plated  
 m = 19.1 g

grey, 1 pce.	0.0.635.09
--------------	------------





## Multiblocks X 8 PA

- Compatible with Profiles X
- Easy-to-use fastening for pre-drilled panel elements
- Variable thanks to two contact faces
- Screw attachment ensures a firm hold for panel elements



5

The shape and colour of Multiblocks X 8 PA matches Profiles X 8. Multiblocks X 8 PA each have two contact faces for panel elements of different thicknesses.



To insert Multiblock X PA in profiles with closed grooves, it is recommended to remove the groove cover at the relevant location using a counterbore. The Step Drill, Universal Connection 6 (Art. No. 0.0.431.19) is ideal for this purpose. The required counterbore depth is just 2 mm!

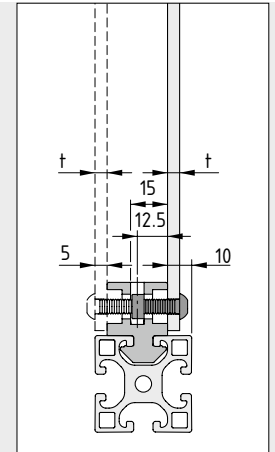
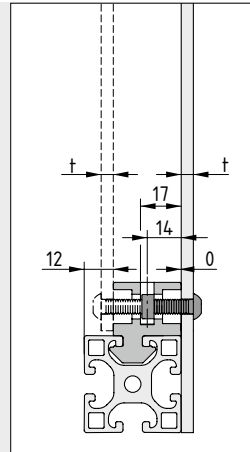
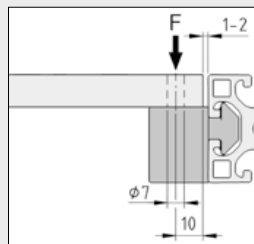

Recommendation for mounting the panel element. The permissible load for Multiblocks X 8 PA is  $F = 250 \text{ N}$ .

The length of the fastening screw depends on the thickness of the panel element.

When using a thick panel element, the Multiblock can be secured from the inside by drilling and tapping a blind hole in the panel. In such a case, the square nut can be removed from the Multiblock.

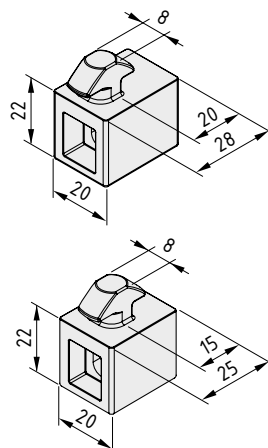

### Multiblock X 8 PA 0/12 mm



Basic unit, PA-GF  
 Spring, St, stainless  
 Square nut DIN 557-M6, St, bright zinc-plated  
 $m = 18.0 \text{ g}$   
 grey, 1 pce.

0.0.603.14

### Multiblock X 8 PA 5/10 mm



Basic unit, PA-GF  
 Spring, St, stainless  
 Square nut DIN 557-M6, St, bright zinc-plated  
 $m = 15.0 \text{ g}$   
 grey, 1 pce.

0.0.603.15



## Multiblocks Zn

High-strength panel fastening

- Exceptionally stable fixings
- Panel elements are securely held by screw fixings
- Easy adjustment for material thickness



For fixing panel elements to profile grooves, particularly where heavy loads are involved. Multiblock Zn is screwed to the profile groove with a screw and T-Slot Nut. The anti-torsion pin, which is adjustable in millimetre increments, ensures flush attachment for panels of

different thicknesses. The panel elements must be drilled in the appropriate position to line up with either the through bore or the square nut (which is secured against falling out by a leaf spring) incorporated in the Multiblock.

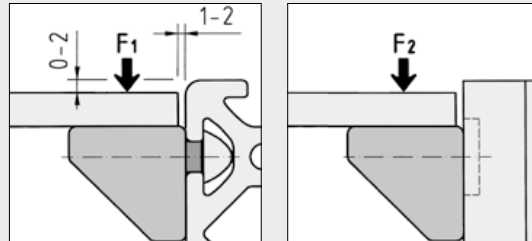

	F <sub>1</sub> [N]	F <sub>2</sub> [N]
	1,000	500
	2,000	1,000

Recommended mounting arrangement and load data across and along the groove.

### Multiblock 6 Zn

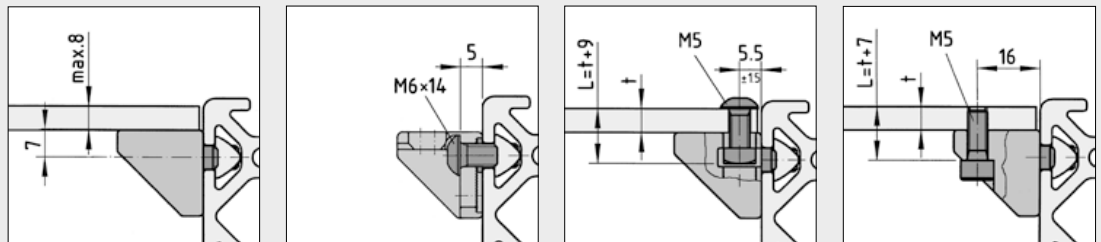

### Multiblock 8 Zn

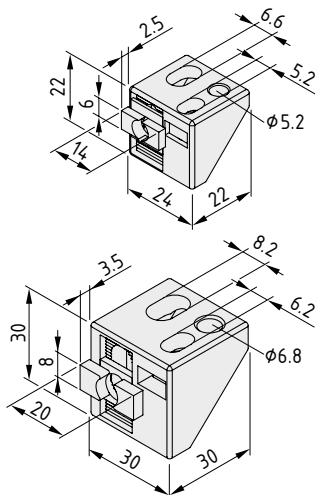
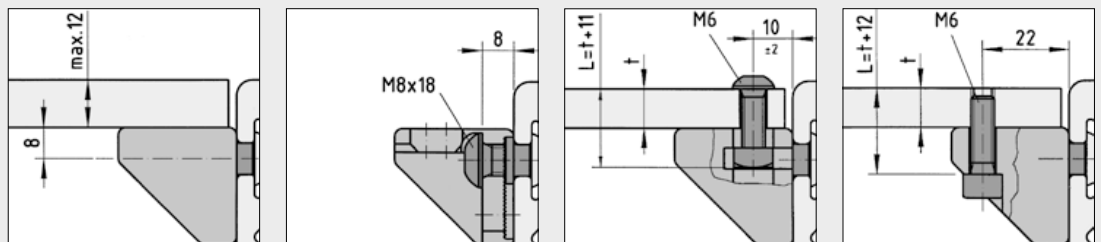

#### Multiblock 6 Zn

Basic unit and locating lug, die-cast zinc, black  
Square nut DIN 557-M5, St, bright zinc-plated  
Leaf spring, St, stainless  
m = 44.0 g

1 pce.

0.0.439.85

#### Multiblock 8 Zn

Basic unit and locating lug, die-cast zinc, black  
Square nut DIN 557-M6, St, bright zinc-plated  
Leaf spring, St, stainless  
m = 66.0 g

1 pce.

0.0.373.23



## Safety Fastening Set Multiblock 8

**Safe and secure.**

- For use with Multiblock 8 PA and 8 Zn
- Creates a permanently joined unit after fitting



5

Panel fastening in line with Machinery Directive 2006/42/EC: Safety Fastening Set Multiblock 8. After fitting, the screw and retaining spring form a single, permanently joined unit that is secured in the through hole. You will always be able to tell when a screw has become loose by the position of the panel element.

Suitable for use with Multiblocks 8 PA and Zn and with Multi Bracket 12 Zn for panel thicknesses from 2 to 10 mm.

Security L-Key Set 596

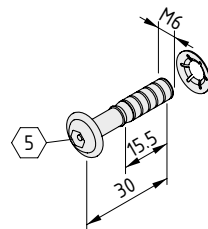

### Safety Fastening Set Multiblock 8



Security flanged button head screw M6x30, St, bright zinc-plated  
Retaining spring M6, St, stainless  
m = 7.5 g

1 set

0.0.626.63



## Multi Bracket 12 Zn

- For fastening panel elements to Profiles 12
- Simple adjustment to the height of the element



Universal element for fastening panels to Line 12 profiles. Since the location lug can be adjusted in various positions within the bracket across the profile groove, panels can be positioned virtually flush with the outer face of the profile irrespective of their thickness.

Multi Bracket 12 can be moved along the profile groove so that it can be easily aligned with the hole in the panel element.

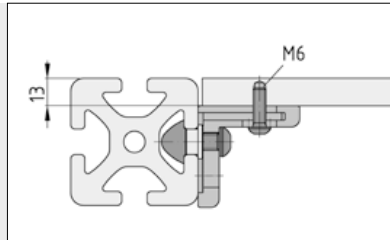

The panel element with through hole is secured by means of an M6 bolt fitted into the square nut of Multi Bracket 12 Zn.

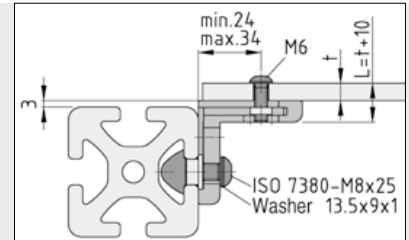

If the panel element is of sufficient thickness, Multi Bracket 12 can also be secured internally so that the fastening is not visible and cannot be detached.

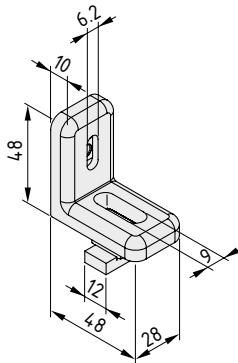

### Multi Bracket 12 Zn



Bracket, die-cast zinc, RAL9006 white aluminium  
 Locating lug, die-cast zinc, RAL9006 white aluminium  
 Square nut DIN 562-M6, St, bright zinc-plated  
 Retaining plate, St  
 m = 120.0 g

1 set

0.0.007.18



## Anti-Loss Washer

- Hold screws securely and permanently in their holes
- Simply push on and screw into place
- Can be easily combined with Multiblocks or Angle Brackets

5

Create captive screws for a whole range of fasteners such as Multiblocks and Angle Brackets using the universal Anti-Loss Washers (M4, M5 and M6). Simply place these onto a screw that has been inserted into its through hole and, when the screw connection is dismantled, the screw will be held safely and securely in the through hole of the panel element.

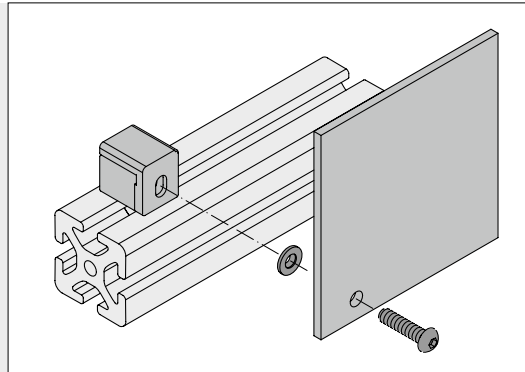

A mounting aid and safety device in one.

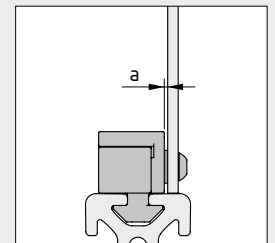

Note: the thickness of the washer (a) determines the position of the panel element.

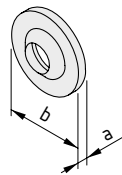

### Anti-Loss Washer M4

PA  
 a = 1.2 mm    b = 9.0 mm    m = 0.1 g  
 natural, 1 pce. 0.0.627.71

### Anti-Loss Washer M5

PA  
 a = 1.65 mm    b = 10.1 mm    m = 0.1 g  
 natural, 1 pce. 0.0.627.70

### Anti-Loss Washer M6

PA  
 a = 1.3 mm    b = 12.5 mm    m = 0.2 g  
 natural, 1 pce. 0.0.627.69

5



## Quick Multiblocks with Securing Pin and with Slotted Pin

- For rapid opening and closing
- No tools required
- Plastic or metal pin, as required



Quick Multiblocks 8 offer the option of fastening a panel element securely in a profile frame in such a way that it can easily be removed. The securing pin is operated either by hand without the need for a tool or using a coin (Quick Multiblock 8 with Slotted Pin).

Lightweight metal sheet and panel elements made from Acrylic Glass, Plastic or Compound Material must be provided with a drill hole at the appropriate location. They are locked in place using the securing pin.

Plastic securing pins are suitable for very occasional operation and die-cast zinc pins for more frequent use or high loads.

Quick Multiblocks 8 can be moved within the groove in order to align them with the hole in the panel element.

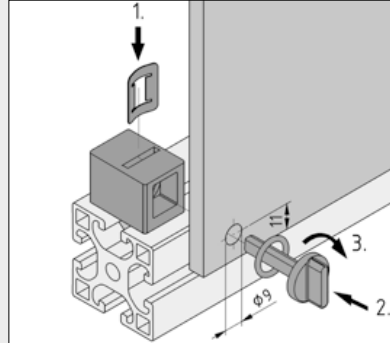

Quick Multiblocks can be used for panel elements of any thickness (up to 8 mm). They can be adapted to the thickness of the panel thanks to two different mounting positions (4 or 8 mm from the edge of the profile). The spring clip is to be inserted in the Quick Multiblock according to the direction in which the load is applied. The concave side of the spring must face the panel and pin. Locking the pin also tightens the spring.

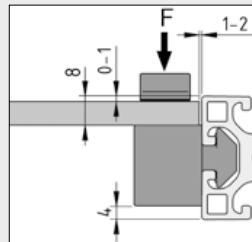

Recommendation for mounting the panel element. The permissible load for Quick Multiblocks 8 is  $F = 250 \text{ N}$ .

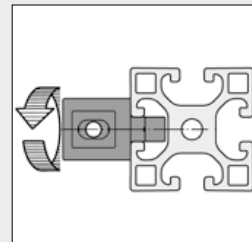

Quick Multiblock 8 is inserted in the profile groove and locked in place with a 90° turn to the right.

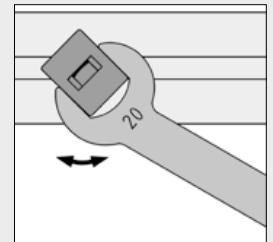

A wrench 20 A/F is recommended for this operation.

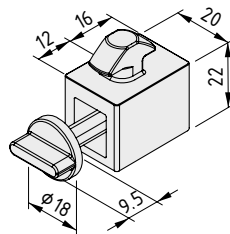

### Quick Multiblock 8 with Securing Pin PA



Basic unit, PA-GF  
Spring clip, St, stainless  
O-ring 12x2, NBR, black  
Securing pin PA  
 $m = 14.0 \text{ g}$

grey, 1 pce.

0.0.604.10

### Quick Multiblock 8 with Securing Pin Zn



Basic unit, PA-GF  
Spring clip, St, stainless  
O-ring 12x2, NBR, black  
Securing pin die-cast zinc  
 $m = 23.0 \text{ g}$

grey, 1 pce.

0.0.603.41

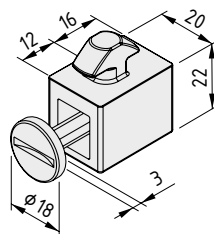

### Quick Multiblock 8 with Slotted Pin Zn



Basic unit, PA-GF  
Spring clip, St, stainless  
O-ring 12x2, NBR, black  
Slotted pin die-cast zinc, white aluminium  
 $m = 20.0 \text{ g}$

grey, 1 pce.

0.0.603.42



## Quick Multiblock 8 with Non-Removable Pin

### The quick-action non-removable fastening

- Prevent inadvertent opening of fixings
- Secure panel fastening – cannot be released without being destroyed



5

It doesn't get any faster: push the non-removable pin through the hole in the panel element and into the Quick Multiblock – that's it, the secure panel fastening cannot be released without destroying it.

Safe and sound: say goodbye to unauthorised access!

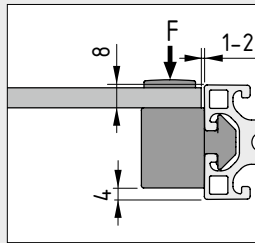

Recommendation for mounting the panel element.  
Permissible loading force for Multiblocks 8 is  $F = 250 \text{ N}$ .

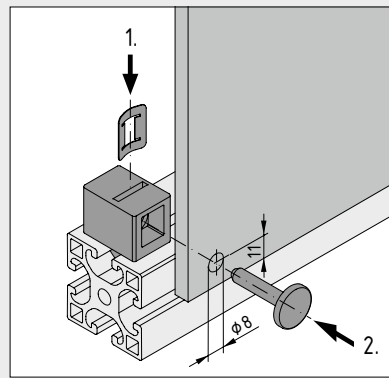

Quick Multiblocks can be used for panel elements of any thickness (up to 8 mm). They can be adapted to the thickness of the panel thanks to two different mounting positions (4 or 8 mm from the edge of the profile). The spring clip is to be inserted in the Quick Multiblock according to the direction in which the load is applied: the convex side of the clip must face away from the panel and pin. Pressing in the pin also tightens the spring.



The head of the pin needs to be broken off before the pin can be removed.

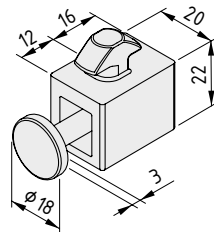

### Quick Multiblock 8 with Non-Removable Pin



Quick Multiblock 8, PA  
Non-removable pin, PA  
Spring clip, St, stainless  
 $m = 14.0 \text{ g}$

black, 1 set	0.0.625.91
grey, 1 set	0.0.625.90

5



## Clamp Multiblocks PA

- For machining-free panel fastening
- Flexible securing clip securely holds panels of different thicknesses



Clamp Multiblocks secure panel elements in profile frames without need for further machining. Clamp Multiblock PA is inserted into the profile groove; a locating lug secures lightweight panel elements of different thicknesses, such as cladding panels, panel elements made from Acrylic Glass, etc.

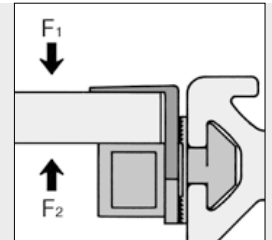
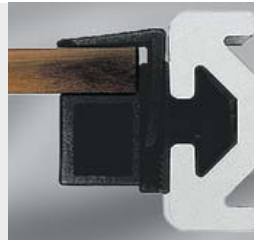

The securing clip can be detached again by means of a screwdriver.

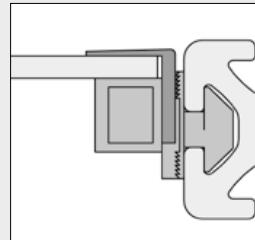
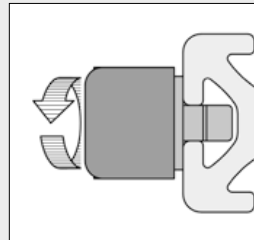

	F <sub>1</sub> [N]	F <sub>2</sub> [N]
5	100	20
6	150	30
8	250	50

The basic unit is twisted into the groove, the panel element fitted and clamped in position by means of the securing clip.

### Clamp Multiblock 5 PA

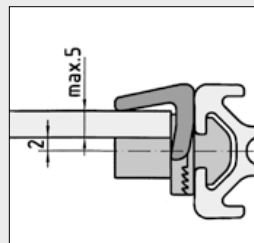
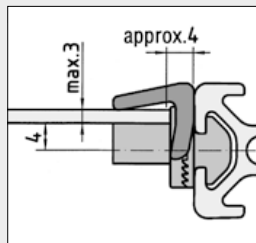

Two mounting dimensions are available depending on the orientation of the Multiblock.

### Clamp Multiblock 6 PA

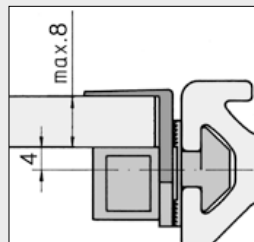
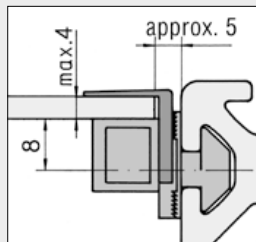

### Clamp Multiblock 8 PA

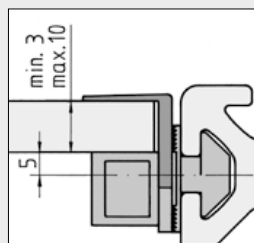
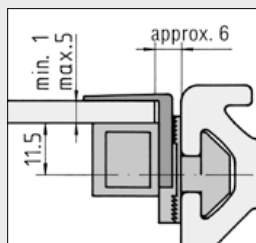



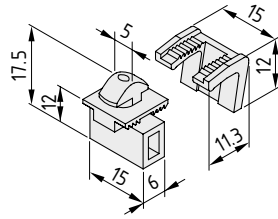

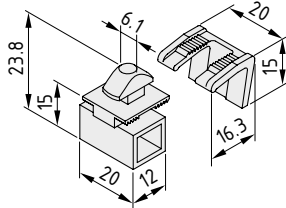

<b>Clamp-Multiblock 5 PA</b> 	
PA-GF Basic unit and securing clip m = 2.0 g	
black, 1 pce.	0.0.437.24
grey, 1 pce.	0.0.641.59

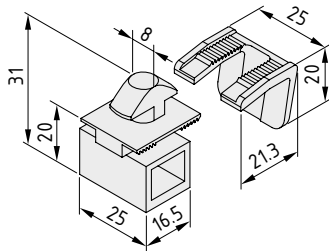

<b>Clamp-Multiblock 6 PA</b> 	
PA-GF Basic unit and securing clip m = 4.0 g	
black, 1 pce.	0.0.439.66
grey, 1 pce.	0.0.636.22



<b>Clamp-Multiblock 8 PA</b> 	
PA-GF Basic unit and securing clip m = 10.0 g	
black, 1 pce.	0.0.196.63
grey, 1 pce.	0.0.641.45





## Panel-Clamping Strips

- Retrofit panels in closed frames
- Existing constructions do not need to be opened up
- Virtually flush with the outer surface of the profile



Panel-Clamping Strips are ideal for retrofitting panel elements (primarily made of Acrylic Glass, PET-G or Polycarbonate) into an assembled profile frame. Apart from straight saw cuts, no further machining of the panel element or Panel-Clamping Strips is required.

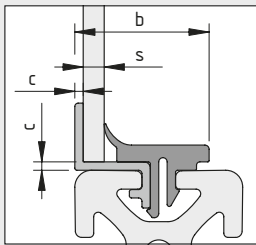

	Al		s [mm]			
	b [mm]	c [mm]	2-4	4-6	6-8	8-10
	24	1.6	2-4	4-6		
	34	2.0	2-4	4-6	6-8	8-10
	42	2.0		4-6		

Panel-Clamping Strips secure the panel element so that there is a minimal offset of 2 mm to the outer edge of the profile. This produces a smooth outer wall for protective enclosures and helps reduce turbulence caused by air flows.

The thickness of the panel element (s) determines which Panel-Clamping Strip is required:

s = 2 - 4 / 4 - 6 / 6 - 8 / 8 - 10 mm

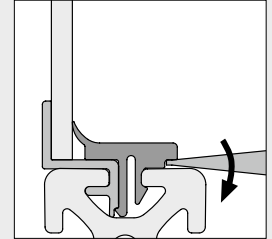
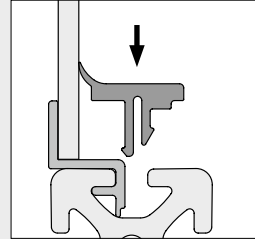

Panel-Clamping Strips consist of two components. The first of these, an aluminium strip, locates into the profile groove and holds the panel element in place. A second strip, made of flexible plastic, is then used to secure both the panel element and the aluminium strip in the groove. If necessary, the plastic strip can be levered out in order to remove the panel element from the frame.

A screwdriver is used to lever out the Panel-Clamping Strip so as to enable removal of the panel element from the frame.

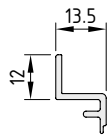

### Panel-Clamping Strip 6 Al



Al, anodized  
m = 124.0 g/m

natural, cut-off max. 3000 mm

0.0.615.01

natural, 1 pce., length 3000 mm

0.0.615.00

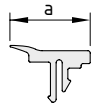

### Panel-Clamping Strip 6 2-4mm



PP/TPE  
a = 21.4 mm m = 85.0 g/m

grey similar to RAL 7042, cut-off max. 3000 mm

0.0.614.94

grey similar to RAL 7042, 1 pce., length 3000 mm

0.0.614.93

### Panel-Clamping Strip 6 4-6mm



PP/TPE  
a = 19.4 mm m = 78.5 g/m

grey similar to RAL 7042, cut-off max. 3000 mm

0.0.614.91

grey similar to RAL 7042, 1 pce., length 3000 mm

0.0.614.90

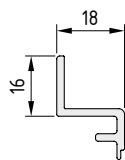

<b>Panel-Clamping Strip 8 Al</b>	
Al, anodized m = 238 g/m	
natural, cut-off max. 3000 mm	0.0.495.05
natural, 1 pce., length 3000 mm	0.0.493.53

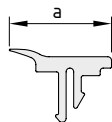

<b>Panel-Clamping Strip 8 2-4mm</b>	
PP/TPE a = 30 mm      m = 151 g/m	
grey similar to RAL 7042, cut-off max. 3000 mm	0.0.495.04
grey similar to RAL 7042, 1 pce., length 3000 mm	0.0.493.75

<b>Panel-Clamping Strip 8 4-6mm</b>	
PP/TPE a = 28.2 mm      m = 142 g/m	
grey similar to RAL 7042, cut-off max. 3000 mm	0.0.495.03
grey similar to RAL 7042, 1 pce., length 3000 mm	0.0.494.64

<b>Panel-Clamping Strip 8 6-8mm</b>	
PP/TPE a = 27 mm      m = 127 g/m	
grey similar to RAL 7042, cut-off max. 3000 mm	0.0.495.02
grey similar to RAL 7042, 1 pce., length 3000 mm	0.0.493.73

<b>Panel-Clamping Strip 8 8-10mm</b>	
PP/TPE a = 25 mm      m = 135 g/m	
grey similar to RAL 7042, cut-off max. 3000 mm	0.0.614.76
grey similar to RAL 7042, 1 pce., length 3000 mm	0.0.614.71

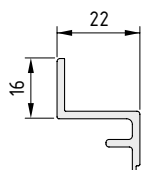

<b>Panel-Clamping Strip 10 Al</b>	
Al, anodized m = 306 g/m	
natural, cut-off max. 3000 mm	0.0.632.89
natural, 1 pce., length 3000 mm	0.0.632.88

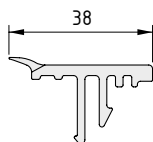

<b>Panel-Clamping Strip 10 4-6mm</b>	
PP/TPE m = 178 g/m	
grey similar to RAL 7042, cut-off max. 3000 mm	0.0.632.91
grey similar to RAL 7042, 1 pce., length 3000 mm	0.0.632.90





## Double Panel Profile 8 Al E

- For building double-walled frame elements
- Extremely easy to fit



Double Panel Profile 8 Al E can be locked into the groove of Profiles 8 without the need for screw connections.

Panel elements can be secured to both sides of the Double Panel Profile using Self-Tapping Screws.

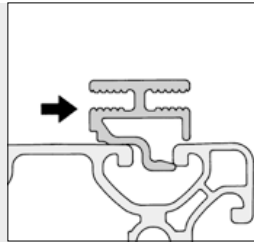

Assembling Double Panel Profile 8 Al E.

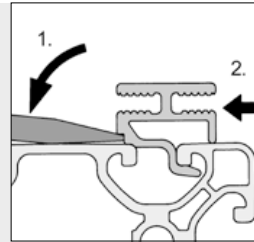

Disassembling Double Panel Profile 8 Al E.

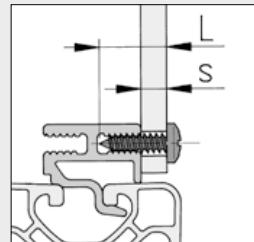
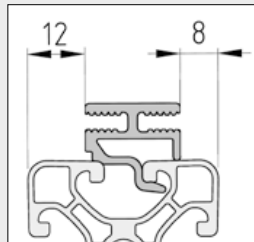
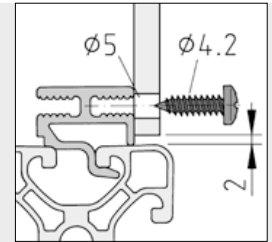

s [mm]	L [mm]
< 3	4.2 x 9.5
3 - 6	4.2 x 13
6 - 9	4.2 x 16
9 - 12	4.2 x 19
12 - 15	4.2 x 22
15 - 18	4.2 x 25

The length of the screws for fixing the panel elements depends on the element's thickness.

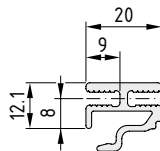

### Double Panel Profile 8 Al E



Al, anodized

A [cm<sup>2</sup>]    m [kg/m]

1.35    0.36

natural, cut-off max. 3000 mm

7.0.001.65

natural, 1 pce., length 3000 mm

0.0.453.71



## Double Panel Profile 8 Al

- For building double-walled frame elements
- Fastening still possible when the groove is already partially in use



5

Double Panel Profile 8 Al is ideal for profile constructions in which the groove cannot be used along its entire length. Fastening to the profile groove is via Clip 8 PA.

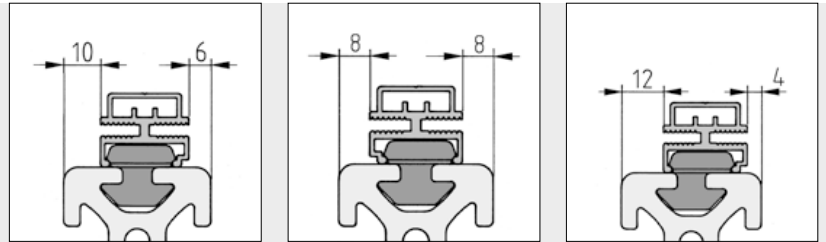

Matching to the wall thickness of the Panel Element by adjusting the positions of Double Panel Profile 8 Al and Clip 8 PA.

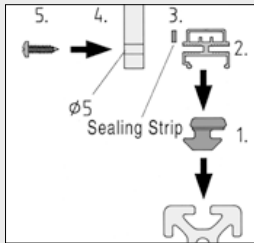

- 1 Clip 8 PA
- 2 Double Panel Profile 8 Al
- 3 Sealing Strip 6x3 sk
- 4 Panel element
- 5 Self-Tapping Screw

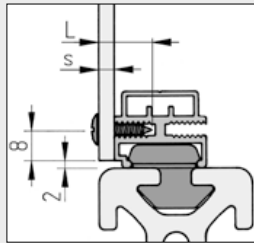

s [mm]	L [mm]
< 3	4.2 x 9.5
3 - 6	4.2 x 13
6 - 9	4.2 x 16
9 - 12	4.2 x 19
12 - 15	4.2 x 22
15 - 18	4.2 x 25

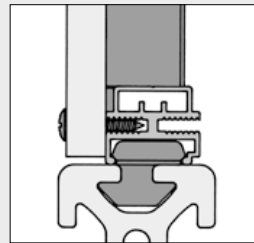

Double Panel Profile in conjunction with Lip Seal 6x3 sk and Sound-Insulating Material 20 mm.

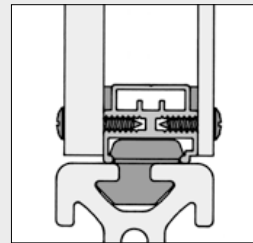

Double Panel Profile in conjunction with Sealing Strip 6x3 sk when used for double-walled constructions.

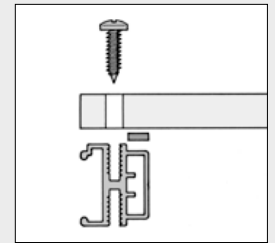

Sealing Strip, self-adhesive on one side, for sealing frame elements. Can also be used as a damping element on mating surfaces, particularly in combination with Double Panel Profile 8 Al.

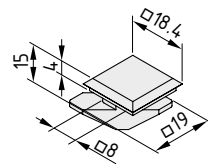
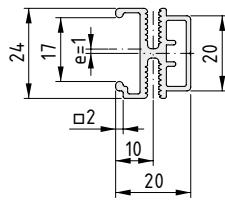

### Double Panel Profile 8 Al



Al, anodized

A [cm<sup>2</sup>]      m [kg/m]

1.62      0.44

natural, cut-off max. 3000 mm

0.0.420.99

natural, 1 pce., length 3000 mm

0.0.453.70

### Clip 8 PA



PA-GF

Recommended number: 4 pce./m

m = 3.0 g

black, 1 pce.

0.0.422.38

The following applies to all the products below:

Cellular rubber  
 closed-cell, self-adhesive on one side  
 Temperature range: -30°C to +110°C  
 Resistant to many oils, fuels, acids and alkaline solutions

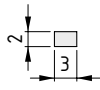

**Sealing Strip 3x2 sk**

m = 1.6 g/m  
 black, 1 pce., length 1000 mm 0.0.479.98

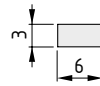

**Sealing Strip 6x3 sk**

m = 3 g/m  
 black, 1 roll length 10 m 0.0.422.66

5



**Panel-Fixing Strip**

- Fasten panels rapidly on Double Panel Profile 8 AL
- No need to machine the panel element

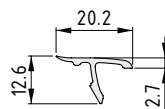
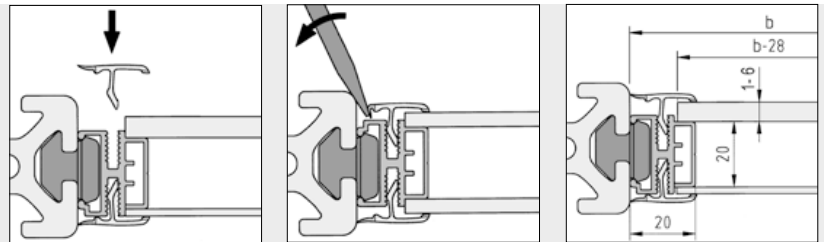

**Panel-Fixing Strip 8**

PVC  
 m = 55 g/m  
 black, 1 pce., length 2000 mm 0.0.429.64





## Listelli angolari Al

- il fissaggio variabile per elementi di qualsiasi tipo
- molto resistente grazie al sicuro ancoraggio nella scanalatura
- utilizzabile come listello di battuta per porte



5

Il fissaggio per elementi piani, scalini o apparecchi di montaggio tra i profilati: il listello angolare passante consente di realizzare costruzioni a tenuta, ad esempio per elementi piani, oppure listelli di battuta per porte.

Elevata capacità di carico grazie ad una distribuzione delle forze ideale e uniforme.

Il listello angolare 8 Al 19" serve per il montaggio di piastre frontali da 19", involucri da 19" o altri componenti piani. In tal caso il fissaggio avviene mediante dadi a gabbia che è possibile inserire nelle aperture passanti quadrate del listello angolare. 1 HE corrisponde a una lunghezza di 44,45 mm

Misure per l'accoppiamento del listello angolare di alluminio ai profilati.

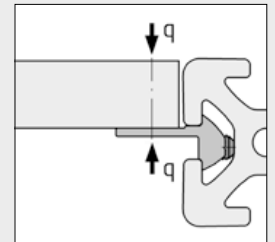
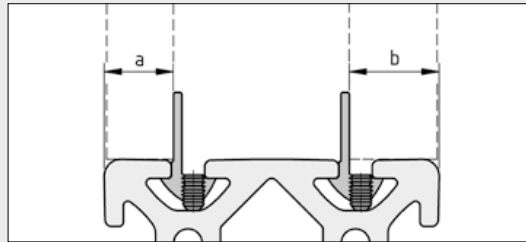
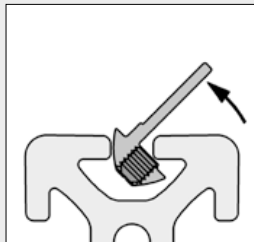
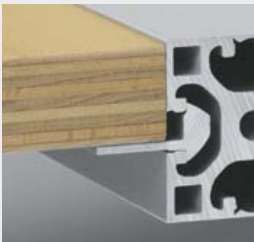

Il listello angolare si inserisce nella scanalatura e si fissa mediante perni filettati. I listelli angolari 8 alluminio 16 M5, 8 alluminio M6 e 10 alluminio M6 sono già provvisti dei fori e dei perni filettati necessari.

Listello angolare	a [mm]	b [mm]	$q_{max}$ [N/m]
8 Al (M6; 19")	10,5	27,0	1.000
8 Al 16 (M5)	16,5	21,5	1.000
10 Al	10,5	36,5	1.200

Carico parziale ammissibile dei listelli angolari.

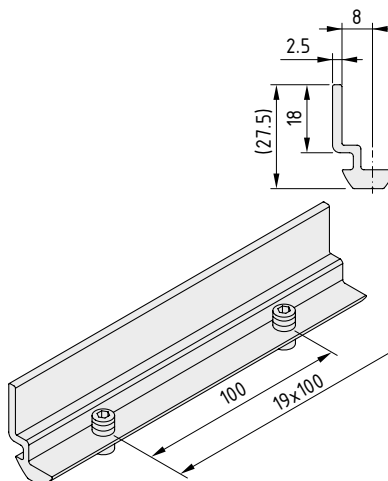

### Listello angolare 8 Al

Al, anodizzato  
m = 310 g/m

naturale, 1 pezzo da 2000 mm

0.0.411.14

### Listello angolare 8 Al M6

Alluminio, anodizzato, naturale  
completamente lavorato con 20 filettature M6  
inclusi grani filettati DIN 913-M6x12, acciaio, zincati  
m = 540,0 g

naturale, 1 pezzo da 2000 mm

0.0.444.89

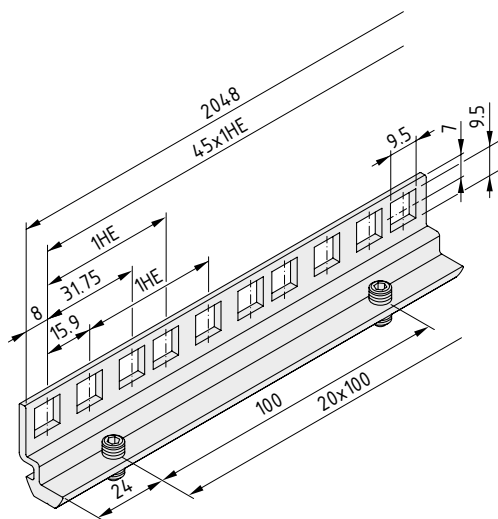

### Listello angolare 8 Al 19"



Alluminio, anodizzato, naturale  
 completamente lavorato con fori e 21 filettature M6 inclusi grani filettati DIN  
 913-M6x12, acciaio, zincati  
 m = 576,0 g

naturale, 1 pezzo da 2048 mm

0.0.398.19

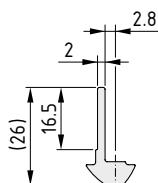

### Listello angolare 8 Al 16



Al, anodizzato  
 m = 268 g/m

naturale, 1 pezzo da 2000 mm

0.0.607.10

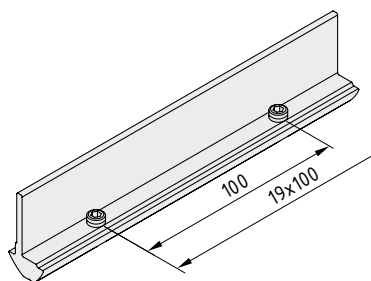

### Listello angolare 8 Al 16 M5



Alluminio, anodizzato, naturale  
 completamente lavorato con 20 filettature M5  
 incluse le viti senza testa DIN 913-M5x6  
 m = 554,0 g

naturale, 1 pezzo da 2000 mm

0.0.605.21

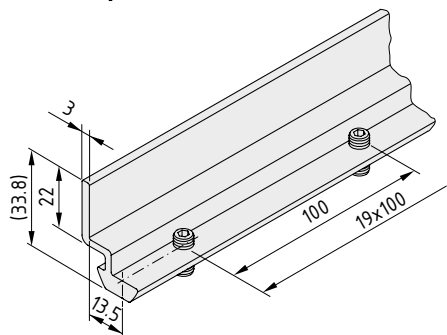

### Listello angolare 10 Al M6



Alluminio, anodizzato, naturale  
 completamente lavorato con 20 filettature M6  
 inclusi grani filettati DIN 913-M6x14, acciaio, zincati  
 m = 1000,0 g

naturale, 1 pezzo da 2000 mm

0.0.625.30





### Captive Nuts

- Nut clips into Rebate Profile 8 Al 19"
- Quickly fitted and removed

Universal usage for installation in Rebate Profile 8 Al 19" or in panel elements. The Captive Nuts can be installed by snapping the latch springs into the corresponding recess.

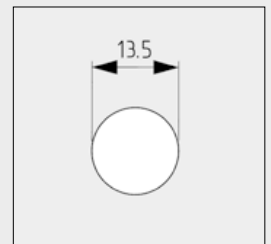
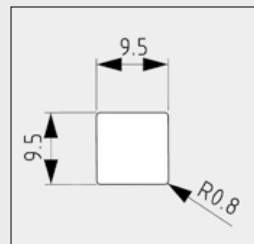
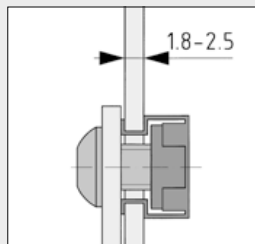

The recesses can be either:  
 - Square - with anti-torsion feature  
 - Round - no anti-torsion feature

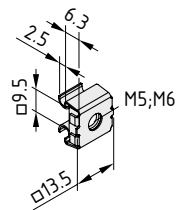

#### Captive Nut M5

St  
 Cage and square nut  
 m = 5.0 g  
 bright zinc-plated, 1 pce. 0.0.411.62

#### Captive Nut M6

St  
 Cage and square nut  
 m = 5.0 g  
 bright zinc-plated, 1 pce. 0.0.411.63

5



## Panel Clamp

- Fasten panel elements without needing to machine them
- Clamping screw fastens the panel and Panel Clamp to a profile



For securing panel elements to Profiles 8 without the need for additional machining. Tightening the clamping screw fixes the Panel Clamp to both the panel element and the profile.

Particularly suitable for attachment of unframed panels etc. Not suitable for mesh and corrugated mesh. The panel elements of thickness 4 - 10 mm can be clamped in position by the asymmetrical spacer washers. Depending on the particular application, it may be necessary to invert the spacer washers in the housing.

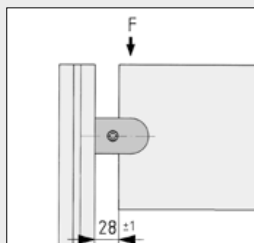
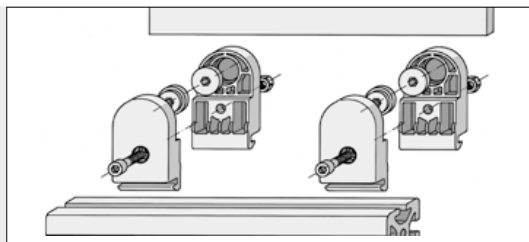

Max. loading for each Panel Clamp without pinning.  
 $F_{max} = 100 \text{ N}$

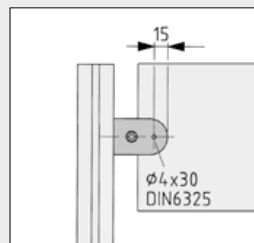

Possible pinning position for securing the panel element against movement.

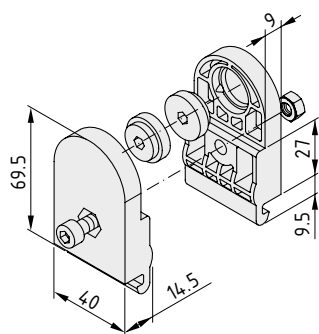

### Panel Clamp 8



- 2 housing halves, PA-GF, black
- Hexagon Socket Head Cap Screw DIN 912-M6x20, St, bright zinc-plated
- Hexagon Nut DIN 934-M6, St, bright zinc-plated
- 2 spacer washers, NBR, black
- $m = 56.0 \text{ g}$

1 set

0.0.388.91



## Panel Clamp X 6-8

- Elegant support that holds panels without the need for machining work
- Elastic inserts dampen vibrations
- Rigid fastening thanks to internal bolts



5

Panel Clamp X 6-8 is a fastener for unframed panels (4 - 8 mm thick) that does not require any further machining of the panel element. The panel element is held securely by elastic inserts.

Fitting the panel element securely using internal bolts is also an option.

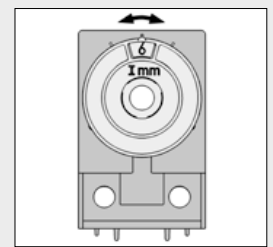
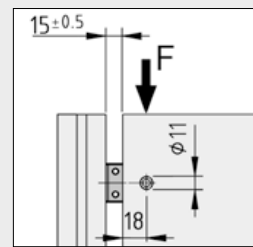
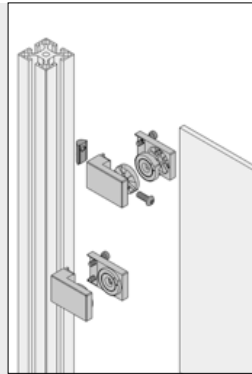

The Panel Clamp is fastened in the groove in Profiles 8 using a screw connection with T-Slot Nut 8. When using the Panel Clamp with Line 6 profiles, a T-Slot Nut 6 St M6 with a Button-Head Screw M6x14 is required. The anti-torsion elements are also to be removed as appropriate for this purpose.

A clearance of 15 mm is to be ensured when cutting the panel element. When using fastening bolts, through bores with a diameter of 11 mm also need to be cut. Max. load for each Panel Clamp without a fastening bolt  $F_{max.} = 100 \text{ N}$ .

The Panel Clamp can be adapted to panel elements between 4 and 8 mm thick by turning the elastomer inserts. A window in the insert shows the selected panel thickness.

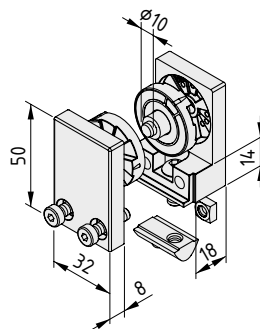

### Panel Clamp X 6-8



- 2 housing components, die-cast zinc, white aluminium
- 2 inserts, PUR, transparent
- Bolt D6x21.5, St, bright zinc-plated
- Collar D6/D10, PUR, grey
- T-Slot Nut V 8 St M6, bright zinc-plated
- Button-Head Screw ISO 7380-M6x16, St, bright zinc-plated
- 2 Hexagon Socket Head Cap Screws DIN 7984-M5x20, St, bright zinc-plated
- 2 square nuts similar to DIN 557-M5, St, bright zinc-plated
- m = 175.0 g

1 set

0.0.605.41



## Support Arm X 6-8

- Aesthetically appealing support for shelving
- Concealed clamping system provides a secure fixing



Support Arm X 6-8 is a support for glass shelves or other inherently stable panel elements. Rear clamping of the panel element allows cantilever fastening to a Line 6 or Line 8 profile structure. The form of Support Arm X 6-8 corresponds to the clean contour of profile form X.

The load-carrying capacity of the shelf and the holding force indicated for the Support Arms must not be exceeded. The total load applies to the indicated distances between supports with an even distribution of weight!

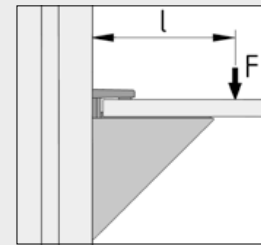
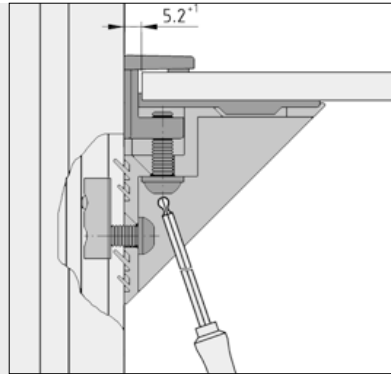

Support Arms X 6-8 are suitable for clamping panel elements 4 to 10 mm thick.

The tightening torque for the tensioning screw must not exceed 3 Nm.

Support Arm X 6-8 is fastened in the groove in Profiles 8 using a screw connection with T-Slot Nut 8. When using Support Arm X 6-8 with Line 6 profiles, a T-Slot Nut 6 St M6 with a Button-Head Screw M6x14 is required.

The permissible depth of the shelf is  $l_{max.} = 200$  mm with a load  $F_{max.} = 80$  N. The distance between two Support Arms should not exceed 500 mm.

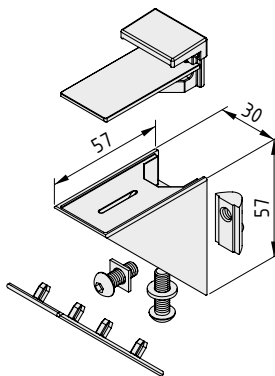

### Support Arm X 6-8



- Angle Bracket, die-cast zinc, white aluminium
- Cap, PA-GF, grey
- T-Slot Nut V 8 St M6, bright zinc-plated
- Button-Head Screw ISO 7380-M6x20, St, bright zinc-plated
- Washer DIN 125-6.4, St, bright zinc-plated
- Button-Head Screw ISO 7380-M6x16, St, bright zinc-plated
- Washer 10.5x10.5x1.3, St, bright zinc-plated
- Clamping element, die-cast zinc, white aluminium
- Support, PUR, grey
- m = 198.0 g

1 set

0.0.496.01



## Table-Top Fastening Set

- Secure table tops to profile frames
- Self-tapping screws for wooden panels included



5

Table-Top Fastening Set 8 is a robust fastening element for table tops made of solid wood or chipboard on profile frame constructions. Clamping in the profile groove is achieved by tightening the self-tapping screw.

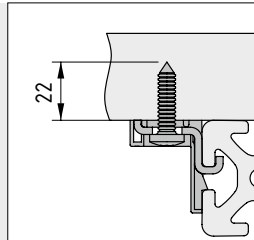

The table top does not need to be processed. The self-tapping screw can be screwed directly into the table top using a screwdriver (TX30 bit). The tolerance is adjusted by means of a slot in Table-Top Fastening Set 8.

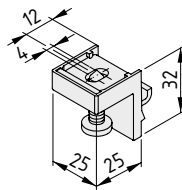

### Table-Top Fastening Set 8



Clamping device, St, bright zinc-plated  
 Cap, PA-GF, black  
 Screw 6x25-TX30, self-tapping, St, bright zinc-plated  
 m = 24.0 g

1 set

0.0.617.63

5



## Flange

- Mounting plate for table columns
- Stable fastening, particularly for Column Profile D110



Flange 8 D130 can be used as a mounting plate for table columns with Column Profile D110. It can be screwed to a table top, a base plate or directly to the floor.

Flange 8 D130 is screwed to Column Profile D110 by means of 2 Countersunk Screws DIN 7981-M8x25. To do this, M8 threads must be tapped into the core bores ( $\varnothing$  6.8 mm) in the Column Profile.

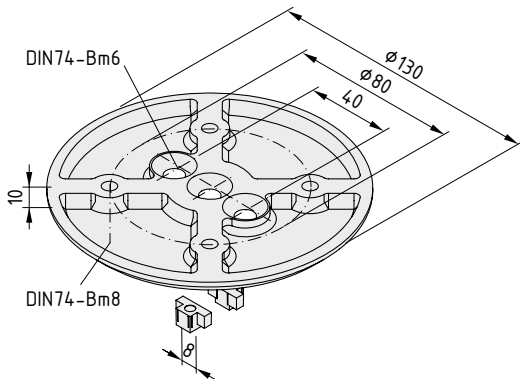

### Flange 8 D130



Die-cast zinc  
 2 anti-torsion lugs, die-cast zinc, galvanized  
 m = 399.0 g  
 white aluminium, similar to RAL 9006, 1 set

0.0.474.82