

Rotary actuators Series ARP

Model: "Rack & Pinion"

Sizes: 1, 3, 5, 10, 12, 20, 35, 55, 70, 100, 150, 250, 400

Rotational angles: 90°

1

MOVEMENT



- » ATEX certified product
- » Wide range of available sizes
- » Air connections in accordance with Namur VDI/VDE 3845 drilling
- » Interface drilling of the process valve in accordance with ISO 5211 standard

The rotary actuators Series ARP has been designed to meet the high demands by the process industry, where they predominantly are used for controlling the opening and closing process valves whereas ball valves and butterfly valves are the most common types.

The actuators exist in thirteen different sizes in order to cover a wide range of applications. Through adjusting screws located on the end caps it is possible to mechanically adjust the opening/closing angle by $\pm 5^\circ$.

All rotary actuators Series ARP are ATEX certified, the air connections are realized in accordance with Namur VDI/VDE 3845 drilling, while the interface drilling of the process valve is in accordance with ISO 5211 standard.

GENERAL DATA

Type of construction	Rack and pinion type
Operation	spring return (single-acting), double-acting
Materials	extruded AL-profile body (pressure diecasted anodized AL body for mod. ARP400) pressure diecasted AL end caps and pistons / racks (end caps in technopolymer for mod. ARP001) zinc-plated steel pinion - POM guide parts - NBR seals
Sizes	001, 003, 005, 010, 012, 020, 035, 055, 070, 100, 150, 250, 400
Operating temperature	- 30°C ÷ 100°C
Rotation angle	90°
Type of mounting	direct to the flange of the valve through screws and bolts, or through mounting kits consisting of bracket and adaptor pin*
Operating pressure	2 ÷ 10 bar
Fluid	filtered air without lubrication. If lubricated air is used, it is recommended to use oil ISOVG32. Once applied the lubrication should never be interrupted.
Available spare part kits	- kits which include sliding parts and seals; - kits containing springs for transforming an actuator from double-acting to single-acting with spring return.
Certification	ATEX

* Bracket and adaptor pin is not supplied by Camozzi

CODING EXAMPLE

ARP	-	001	-	1A	A	-	F0300	-	A	EX
------------	---	------------	---	-----------	----------	---	--------------	---	----------	-----------

ARP	SERIES									
001	SIZE 001 = torque force 9 Nm 003 = torque force 24 Nm 005 = torque force 50 Nm 010 = torque force 100 Nm 012 = torque force 120 Nm 020 = torque force 200 Nm 035 = torque force 370 Nm 055 = torque force 597 Nm 070 = torque force 825 Nm 100 = torque force 1122 Nm 150 = torque force 1655 Nm 250 = torque force 2648 Nm 400 = torque force 4800 Nm									
1A	OPERATION 1A = single-acting, minimum pressure of 4 bar 1B = single-acting, minimum pressure of 5 bar 1C = single-acting, minimum pressure of 5,5 bar 1D = single-acting, minimum pressure of 6 bar 2A = double-acting					PNEUMATIC SYMBOLS CD19 CD19 CD19 CD19 CD17				
A	ROTATION ANGLE A = 90°									
F0300	INTERFACE FOR FLANGE (ISO 5211) F0300 = F03 flange and 9mm square holes F0305 = F03 flange holes + F05 flange and 9mm square holes F0400 = F04 flange and 11mm square holes F0507 = F05 flange holes + F07 flange and 14mm square holes F0705 = F07 flange holes + F05 flange and 17mm square holes F0710 = F07 flange holes + F10 flange and 17mm square holes F1007 = F10 flange holes + F07 flange and 22mm square holes F1210 = F12 flange holes + F10 flange and 27mm square holes F1400 = F14 flange and 36mm square holes F1600 = F16 flange and 46mm square holes F2516 = F25 flange + F16 flange and 55mm square holes									
A	MATERIALS A = standard anodized C = CNI Kanigen type nickel-plating W = all FKM seals (130°C)									
EX	ATEX certified product									

PNEUMATIC SYMBOLS

The pneumatic symbols which have been indicated in the CODING EXAMPLE are shown below.



TORQUE FORCE DIAGRAM GENERATED BY A DOUBLE-ACTING ACTUATOR

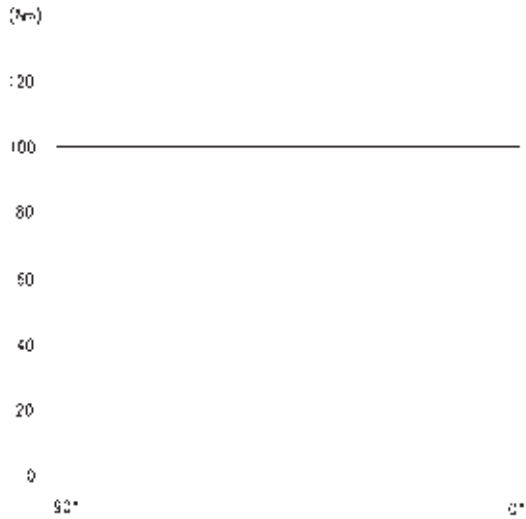

The above graph shows the torque force (in Nm) generated by a double-acting rotary actuator Series ARP during the closing action. The action starts from the 90° position and finishes at 0°. One of the features/advantages with a “rack and pinion” style rotary actuator is that the generated torque force is constant throughout the whole movement. See also the TORQUE FORCE TABLE on page 1/6.20.04.

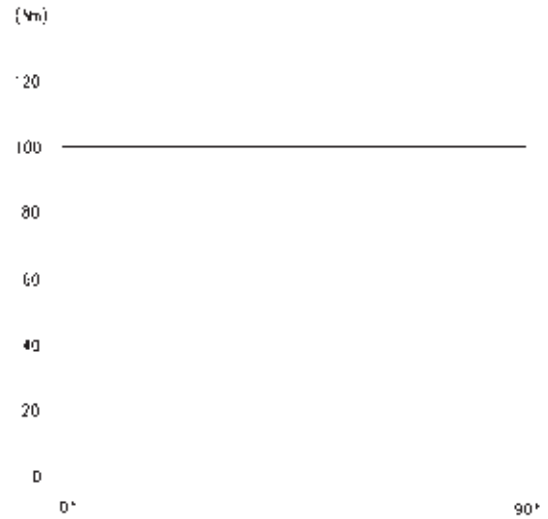

The above graph shows the torque force (in Nm) generated by a double-acting rotary actuator Series ARP during the opening action. The action starts from the 0° position and finishes at 90°. One of the features/advantages with a “rack and pinion” style rotary actuator is that the generated torque force is constant throughout the whole movement. See also the TORQUE FORCE TABLE on page 1/6.20.04.

TORQUE FORCE DIAGRAM GENERATED BY A SINGLE-ACTING ACTUATOR

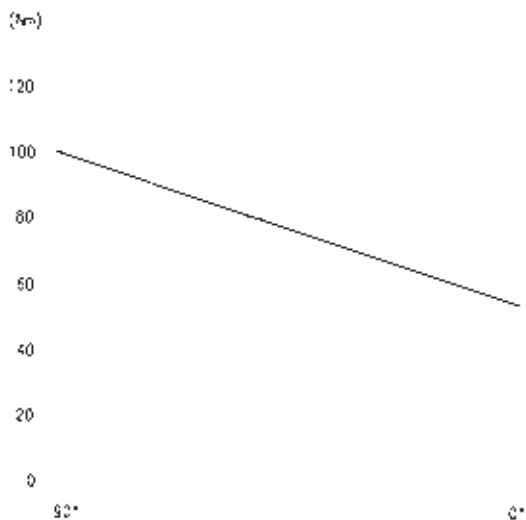

The above graph shows the torque force (in Nm) generated by a single-acting rotary actuator Series ARP during the closing action. The action starts from the 90° position and finishes at 0°. The generated torque force is at the highest at 90°, while it decreases along the stroke due to the fact that the springs get less compressed. In this case it is the springs which generates the driving force. See also the TORQUE FORCE TABLE on page 1/6.20.04.

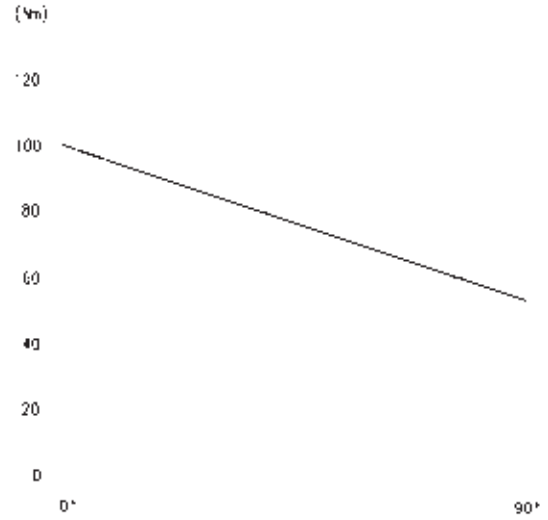

The above graph shows the torque force (in Nm) generated by a single acting rotary actuator Series ARP during the opening action. The action starts from the 0° position and finishes at 90°. The generated torque force is at the highest at 0°, while it decreases along the stroke due to the fact that the springs get more compressed, (the counter force increases). In this case it is the compressed air which generates the driving force. See also the TORQUE FORCE TABLE on page 1/6.20.04.

TORQUE FORCE TABLE (Nm)

MOVEMENT

DOUBLE-ACTING models	3 bar	4 bar	5 bar	5,5 bar	6 bar	7 bar
ARP-001-2A	4,4	5,8	7,33	8,0	8,8	10,2
ARP-003-2A	11,8	15,8	19,7	21,7	23,7	27,6
ARP-005-2A	25,3	33,8	42,2	46,4	50,7	59,1
ARP-010-2A	50,7	67,6	84,5	92,9	101,4	118,3
ARP-012-2A	61,2	81,6	102,1	112,2	122,5	142,9
ARP-020-2A	100,9	134,6	168,2	185,08	201,9	235,5
ARP-035-2A	187,0	249,3	311,6	342,8	374,0	436,3
ARP-055-2A	298,5	398,0	497,5	547,2	597,0	696,5
ARP-070-2A	412,5	550,0	687,5	756,2	825,0	962,5
ARP-100-2A	561,0	748,0	935,0	1028,5	1122,0	1309,0
ARP-150-2A	827,5	1103,3	1379,1	1517,0	1655,0	1930,8
ARP-250-2A	1324,0	1765,3	2206,6	2427,3	2648,0	3089,3
ARP-400-2A	2401,5	3202,0	4002,5	4402,7	4803,0	5603,5

SINGLE-ACTING models (for rotation angles of 90°)	Quantity of springs		Spring torque (Nm)	Supply pressure of 4 bar	Supply pressure of 5 bar	Supply pressure of 5,5 bar	Supply pressure of 6 bar
	External	Internal	0° - 90°	0° - 90°	0° - 90°	0° - 90°	0° - 90°
ARP-003-1AA	8	- /	5,36 - 10,48	10,40 - 5,30	11,80 - 7,90	16,40 - 11,20	18,30 - 13,20
ARP-003-1BA	10	- /	6,70 - 13,10		13,10 - 6,70	15,00 - 8,60	17,00 - 10,60
ARP-003-1CA	11	- /	7,37 - 14,41			14,40 - 7,30	16,30 - 9,30
ARP-003-1DA	12	- /	8,04 - 15,72			13,70 - 6,00	15,70 - 8,00
ARP-005-1AA	8	- /	12,00 - 21,76	21,80 - 12,00	30,30 - 20,50	34,50 - 34,70	38,70 - 28,90
ARP-005-1BA	10	- /	15,00 - 27,20		27,30 - 15,10	31,50 - 19,30	35,70 - 23,50
ARP-005-1CA	11	- /	16,50 - 29,92			30,00 - 16,60	34,20 - 20,80
ARP-005-1DA	12	- /	18,00 - 32,64			28,50 - 13,80	32,70 - 18,10
ARP-010-1AA	8	- /	26,72 - 40,96	40,90 - 26,60	57,80 - 43,50	66,20 - 52,00	74,70 - 60,40
ARP-010-1BA	10	- /	33,40 - 51,20		51,10 - 33,30	59,60 - 41,80	68,00 - 50,20
ARP-010-1CA	11	- /	36,74 - 56,32			56,20 - 36,60	64,70 - 45,10
ARP-010-1DA	12	- /	40,08 - 61,44			52,90 - 31,50	61,30 - 40,00
ARP-012-1AA	4	- 0	28,80 - 52,40	52,90 - 29,30	73,30 - 49,70	83,50 - 59,90	93,70 - 70,10
ARP-012-1BA	4	- 2	36,00 - 65,50	54,70 - 16,20	66,10 - 36,60	76,30 - 46,80	86,50 - 57,00
ARP-012-1CA	4	- 3	39,60 - 72,10		62,50 - 30,00	72,70 - 40,30	82,90 - 50,50
ARP-012-1DA	4	- 4	43,20 - 78,60		58,90 - 23,50	69,10 - 33,70	79,30 - 43,90
ARP-020-1AA	4	- 0	47,70 - 86,80	86,90 - 47,80	120,60 - 81,50	137,40 - 98,30	154,20 - 115,10
ARP-020-1BA	4	- 2	53,70 - 108,50	75,00 - 26,10	108,60 - 59,80	125,40 - 76,60	142,30 - 93,40
ARP-020-1CA	4	- 3	65,50 - 119,40		102,60 - 48,90	119,50 - 65,80	136,30 - 82,60
ARP-020-1DA	4	- 4	71,60 - 130,20		96,70 - 38,10	113,50 - 54,90	130,30 - 71,70
ARP-035-1AA	4	- 0	88,40 - 160,80	161,00 - 88,70	223,40 - 151,00	254,60 - 182,20	285,70 - 213,40
ARP-035-1BA	4	- 2	110,50 - 201,00	138,90 - 48,50	201,30 - 110,80	232,50 - 142,00	263,60 - 173,20
ARP-035-1CA	4	- 3	121,60 - 221,10		190,20 - 90,70	221,40 - 121,90	252,60 - 153,10
ARP-035-1DA	4	- 4	132,60 - 241,20		179,20 - 70,60	210,40 - 101,80	241,50 - 133,00
ARP-055-1AA	4	- 0	141,00 - 256,40	256,80 - 141,40	356,30 - 240,90	406,00 - 290,60	455,70 - 340,30
ARP-055-1BA	4	- 2	176,30 - 320,50	221,60 - 77,30	321,00 - 176,80	370,70 - 226,50	420,50 - 279,20
ARP-055-1CA	4	- 3	193,90 - 352,60		303,40 - 144,70	353,10 - 194,50	402,80 - 244,20
ARP-055-1DA	4	- 4	211,50 - 384,60		285,80 - 112,70	335,50 - 162,40	385,20 - 212,10
ARP-070-1AA	4	- 0	195,0 - 354,0	355,0 - 196,0	493,0 - 333,0	561,0 - 402,0	630,0 - 471,0
ARP-070-1BA	4	- 2	243,0 - 443,0	306,0 - 107,0	444,0 - 245,0	513,0 - 314,0	581,0 - 382,0
ARP-070-1CA	4	- 3	268,0 - 487,0		420,0 - 201,0	488,0 - 269,0	557,0 - 338,0
ARP-070-1DA	4	- 4	292,0 - 531,0		395,0 - 156,0	464,0 - 225,0	533,0 - 294,0
ARP-100-1AA	4	- 0	265,0 - 482,0	483,0 - 266,0	670,0 - 453,0	764,0 - 547,0	857,0 - 640,0
ARP-100-1BA	4	- 2	331,0 - 603,0	417,0 - 146,0	604,0 - 333,0	697,0 - 426,0	791,0 - 520,0
ARP-100-1CA	4	- 3	365,0 - 663,0		571,0 - 272,0	664,0 - 366,0	758,0 - 459,0
ARP-100-1DA	4	- 4	398,0 - 723,0		538,0 - 212,0	631,0 - 306,0	725,0 - 399,0
ARP-150-1AA	4	- 0	391,0 - 711,0	712,0 - 392,0	988,0 - 668,0	1126,0 - 806,0	1264,0 - 944,0
ARP-150-1BA	4	- 2	489,0 - 889,0	615,0 - 215,0	890,0 - 491,0	1028,0 - 629,0	1166,0 - 766,0
ARP-150-1CA	4	- 3	538,0 - 977,0		842,0 - 402,0	979,0 - 540,0	1117,0 - 678,0
ARP-150-1DA	4	- 4	586,0 - 1066,0		793,0 - 313,0	931,0 - 451,0	1069,0 - 589,0
ARP-250-1AA	6	- /	606,0 - 936,0	1159,0 - 829,0	1600,0 - 1270,0	1821,0 - 1491,0	2042,0 - 1712,0
ARP-250-1BA	8	- /	808,0 - 1248,0	957,0 - 517,0	1398,0 - 958,0	1619,0 - 1179,0	1840,0 - 1400,0
ARP-250-1CA	9	- /	909,0 - 1404,0		1297,0 - 802,0	1518,0 - 1023,0	1739,0 - 1244,0
ARP-250-1DA	10	- /	1010,0 - 1560,0		1196,0 - 646,0	1417,0 - 867,0	1638,0 - 1088,0
ARP-400-1AA	10	- /	1180,0 - 1820,0	2022,0 - 1382,0	2823,0 - 2183,0	3223,0 - 2583,0	3623,0 - 2983,0
ARP-400-1BA	12	- /	1416,0 - 2184,0	1786,0 - 1018,0	2587,0 - 1819,0	2987,0 - 2219,0	3387,0 - 2619,0
ARP-400-1CA	15	- /	1770,0 - 2730,0		2233,0 - 1273,0	2633,0 - 1673,0	3033,0 - 2073,0
ARP-400-1DA	16	- /	1888,0 - 2912,0			2515,0 - 1491,0	2915,0 - 1891,0

Rotary actuators Series ARP - Sizes from 001 to 150

NOTE TO THE TABLE:

* ARP-003-... also available with double drilling ISO F03/F05 with ØK of 25 mm and square key M of 9 mm

** DA = weight of double-acting version
SA = weight of single-acting version

BB = end-stroke regulation on the end cap
CC = end-stroke regulation on the end cap
DD = solenoid mounting/Namur interface

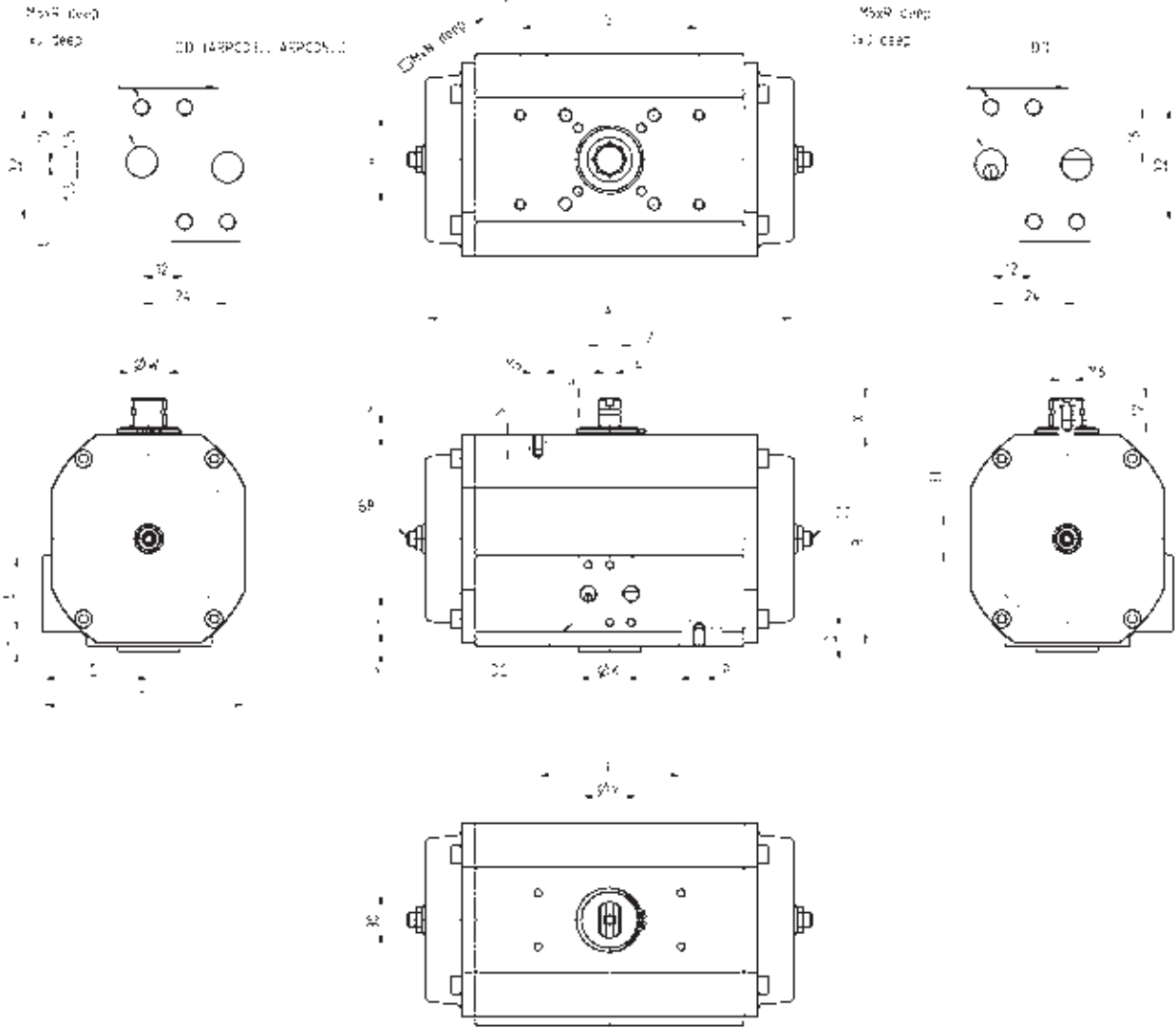

Mod.	ISO	A	B	C	D	E	F	G	H	I	J	ØK	L	□	M	N	P	Q	R	S	T	U	ØV	ØW	X	Y	Z	BB	CC	EE	Weight (Kg)	DA/SA**	
ARP-001-...	F03	103	45	51	28,5	-	-	-	-	G1/8	10	25	22,5	9	11	-	-	8	5	80	2	22,5	16	20	4,5	11,5	-	-	-	-	-	0,6	
ARP-003-...	F04*	149,5	70	69,5	38	49	10,5	-	-	G1/8	10	30	32	11	11	-	-	8	8	80	1,5	32	20	20	4,5	11,5	-	4	13	-	-	1,0 / 1,1	
ARP-005-...	F05, F07	186,5	87	90,5	49	49	22	-	-	G1/8	10	35	48	14	15	-	-	8	8	80	3	32	20	20	4,5	11,5	-	4	13	-	-	1,8 / 1,9	
ARP-010-...	F05, F07	206	118	113	59	43	8	-	-	G1/8	10	35	29,5	14	19	-	-	8	8	80	3	32	20	20	4,5	11,5	-	6	19	-	-	2,8 / 2,9	
ARP-012-...	F07, F05	194	118,5	121	67	43	8	107	49	G1/4	12	55	29,5	17	20	M6	10	8	5	80	3	45	20	20	6	11,5	-	6	19	-	-	4,1 / 4,7	
ARP-020-...	F07, F10	218	140,5	136,5	72	43	8	107	49	G1/4	12	55	29,5	17	20	M6	10	8	5	80	3	50	32	20	6,5	19	-	8	24	-	-	6,3 / 7,0	
ARP-035-...	F10, F07	266	166,5	156	78	43	8,5	161	73	G1/4	12	70	30	22	24	M6	12	8	5	80	3	61	32	20	7	19	-	8	24	-	-	10 / 12	
ARP-055-...	F12, F10	312	207,5	191	95,5	43	20,5	161	73	G1/4	12	85	42	27	30	M8	15	8	5	130	3	61	40	30	7,5	25,5	10	10	30	-	-	18 / 21	
ARP-070-...	F12, F10	358	216	198	99	49	19,5	213	102	G1/4	12	85	46	27	30	M8	12	8	6	130	3	72	40	30	7	25,5	10	10	30	-	-	20 / 24	
ARP-100-...	F14	366	254	227	113,5	43	39,5	213	102	G1/4	12	100	61	36	40	M10	15	8	6	130	3	76	40	30	7	25,5	12	12	36	-	-	31 / 35	
ARP-150-...	F14	394	304	280	140	48,5	51,5	244	117	G1/4	12	100	76	36	40	M12	22	8	6	130	3	78	40	30	7	25,5	12	12	36	-	-	44 / 52	

Rotary actuators Series ARP - Size 250

NOTE TO THE TABLE:

** DA = double-acting - SA = single-acting

 CC = end-stroke regulation on the end cap
 DD = solenoid mounting/Namur Interface

Owing to the end caps sizes, dimensions change from the double-acting model to the single-acting one.

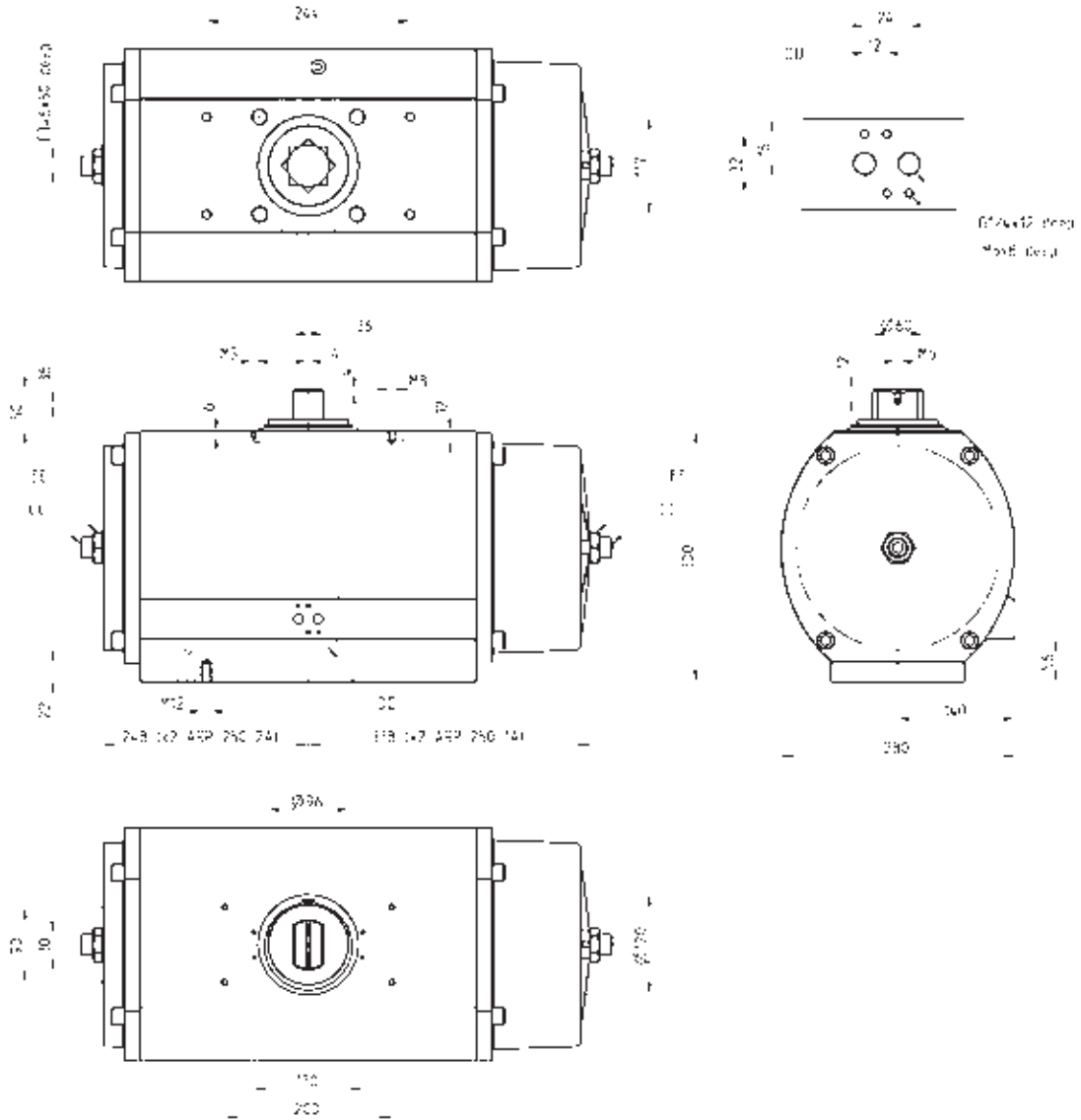

Mod.	ISO	CC	EE	Weight (Kg) DA / SA **
ARP-250...	F16	14	46	59 / 84

Rotary actuators Series ARP - size 400

NOTE TO THE TABLE:
 ** DA = double-acting - SA = single-acting



CC = end-stroke regulation on the end cap
 DD = solenoid mounting/Namur Interface

Owing to the end caps sizes, dimensions change from the double-acting model to the single-acting one.

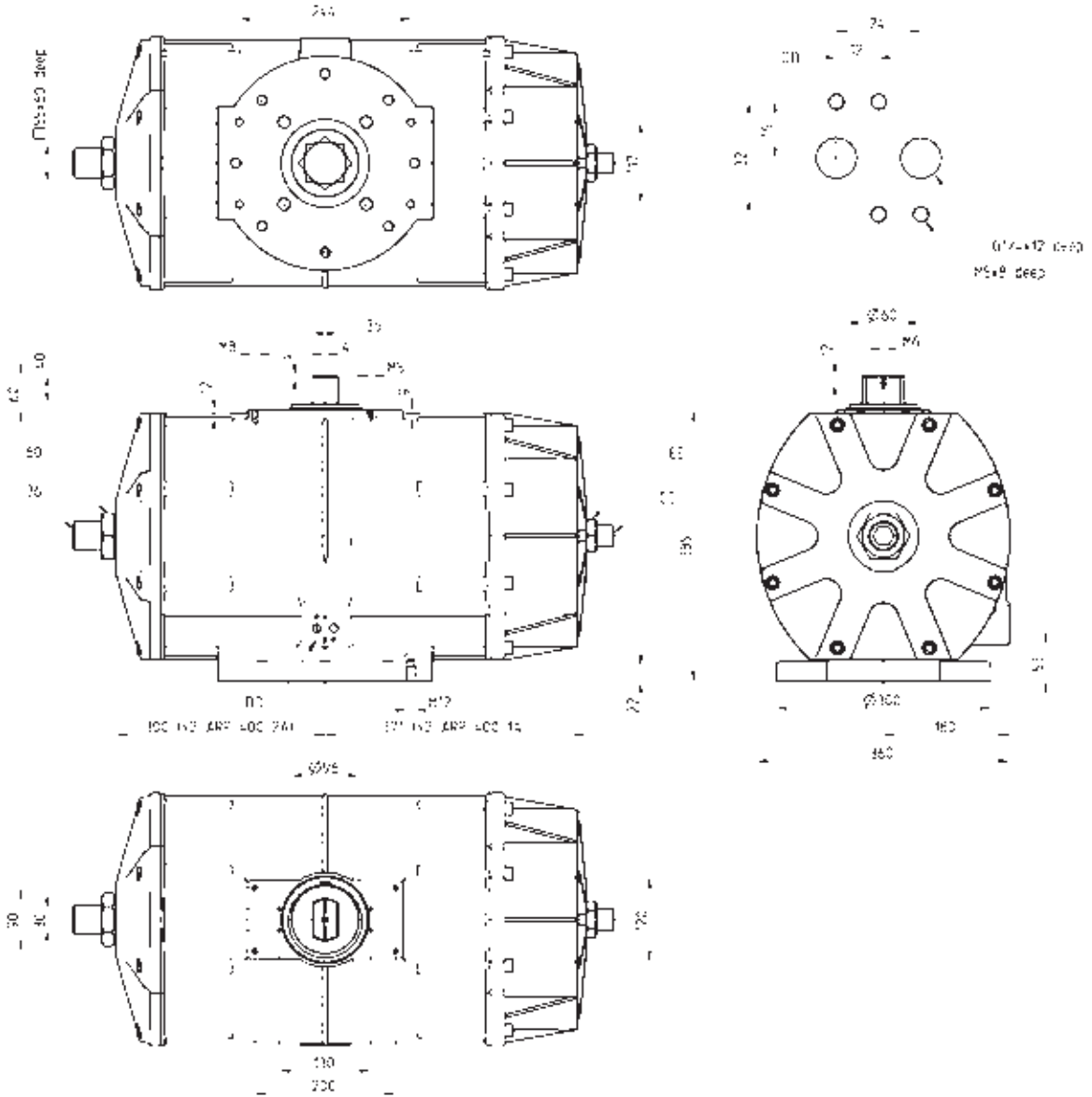

Mod.	ISO	CC	EE	Weight (Kg) DA / SA **
ARP-400...	F25, F16	14	46	107 / 135

Rotary actuators Series ARP

Reference standard ISO 5211 concerning the dimensions of flanges connecting actuator and valve.

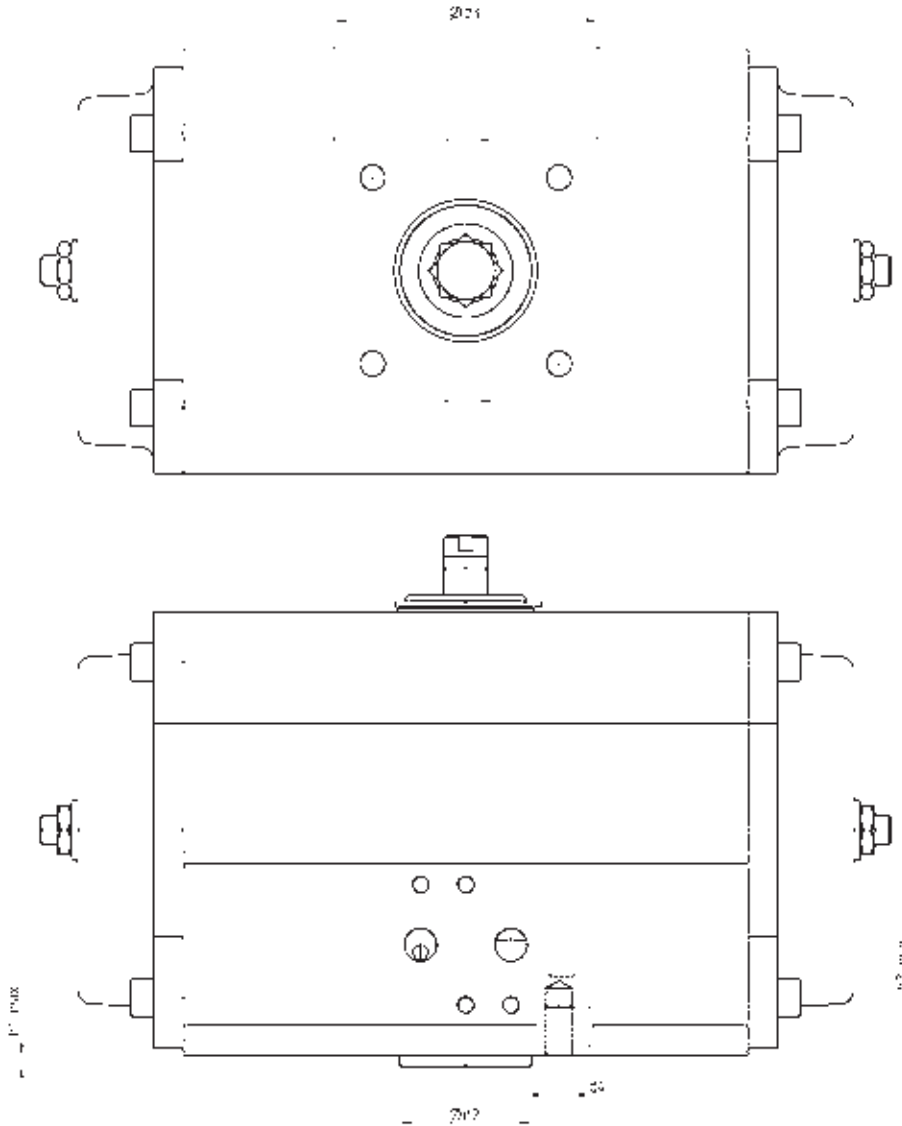

ISO flange	d2 f8	d3	d4	h1 max	h2 min	nr of holes
F03	25	36	M5	3	8	4
F04	30	42	M5	3	8	4
F05	35	50	M6	3	9	4
F07	55	70	M8	3	12	4
F10	70	102	M10	3	15	4
F12	85	125	M12	3	18	4
F14	100	140	M16	4	24	4
F16	130	165	M20	5	30	4
F25	200	254	M16	5	24	8

Switch box Mod. SBT (standard) e SIP (ATEX version)

Mod. SIP: intrinsic safety ATEX version with protection modes Ex II 2 G/D
EEx ia IIC T6 for zones classified as 1, 2, 21 e 22.

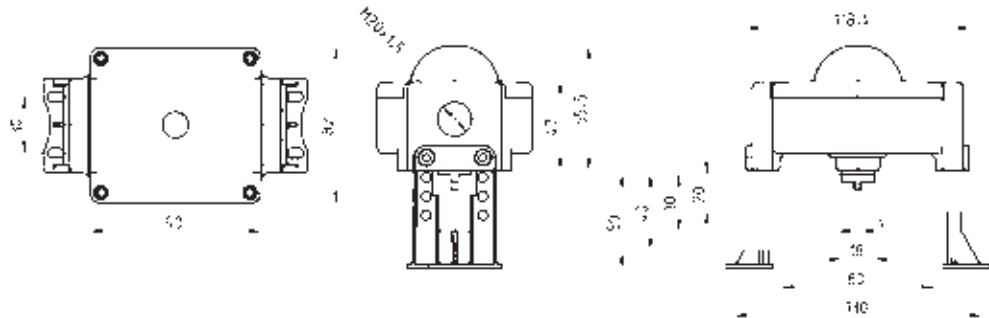

Mod.	Body material	Cover material	Shaft material	Screws	Operating temperature	Protection class	Kind of end stop
SBT-012H0-2H	Technopolymer	Polycarbonate	Technopolymer	Stainless steel	-15°C + 80°C	IP65	2 electromec. end stops SPDT Max 5A 250V AC / 3A 24V DC
SIP702L0-2H	Technopolymer	Polycarbonate	Technopolymer	Stainless steel	-15°C + 80°C	IP65	2 inductive Namur P+F NJ2-V3-N (2 non amplified wires)

Switch box Mod. SBA (standard) e SIM (ATEX version)

Mod. SIP: intrinsic safety ATEX version with protection modes Ex II 2 G/D
EEx ia IIC T6 for zones classified as 1, 2, 21 e 22.

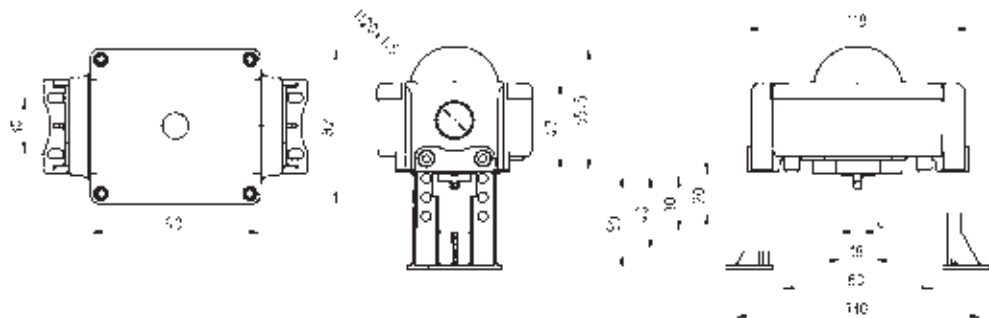

Mod.	Body material	Cover material	Shaft material	Screws	Operating temperature	Protection class	Kind of end stop
SBA-0120N-2H	pressure diecasted Aluminium	Polycarbonate	Technopolymer	Stainless steel	-15°C + 80°C	IP65	2 electromec. end stops SPDT Max 5A 250V AC / 3A 24V DC
SIM702LN-2H	pressure diecasted Aluminium	Polycarbonate	Technopolymer	Stainless steel	-15°C + 80°C	IP65	2 Namur induttivi P+F NJ2-V3-N (2 non amplified wires)