

Cylinders Series 61 Aluminium profile

New version

Single and double-acting, magnetic, cushioned
Standard, low friction and low temperatures versions
ø 32, 40, 50, 63, 80, 100, 125 mm



Cylinders Series 61 have been designed to comply with the dimensions laid down in the ISO 15552 standards. A permanent magnet, mounted on the piston in these cylinders, enables information to be received regarding the piston position by means of proximity switches mounted in grooves along the cylinder profile. These grooves can be covered with a slot cover profile.

This cylinder series is equipped with adjustable end-stroke cushioning. Moreover, these cylinders are equipped with a mechanical cushioning in order to reduce the impact of the piston as it reaches the end of the stroke.

- » In compliance with ISO 15552 standards and with the previous DIN/ISO 6431 - VDMA 24562 standards
- » Rolled stainless steel rod
- » Clean design with adjustable pneumatic cushioning
- » Available special versions
LOW FRICTION:
- » Friction force reduced by over 40%
- » Reduced stick-slip effect
- » Minimum operating pressure down to 0,1 bar
LOW TEMPERATURE:
- » Versions for -40°C and for -50°C
G VARIANT FOR DUSTY APPLICATIONS:
- » Highly resistant to dusty residues (cement, resin, mud, residues from wood, etc...)

GENERAL DATA

Type of construction	with tie-rods (inside the profile)
Operation	double-acting, single-acting, tandem. Low friction version: double-acting only.
Materials	standard: AL end-blocks and piston, rolled stainless steel AISI 420B rod, anodized AL profile tube, zinc-plated steel tie-rods and tie-rod nuts, PU seals; low friction: standard materials with NBR piston seal and NBR rod seal (FKM rod seal on request) low temperature: standard materials with chrome plated stainless steel AISI 420B rod, brass rod scraper ring, stainless steel AISI 303 nuts, stainless steel AISI 420B tie-rods, PU piston seals and NBR rod seal
Type of mounting	with front / rear flange, foot mounting, with front / rear / centre / swivel trunnion
Stroke min - max	10 ÷ 2500 mm
Operating temperature	standard and low friction: 0°C ÷ 80°C (with dry air -20°C) low temperature (-40°C version): -40°C ÷ 60°C (with dry air -40°C) low temperature (-50°C version): -50°C ÷ 60°C (with dry air -50°C)
Operating pressure	1 ÷ 10 bar (standard and low temperature); 0,1 ÷ 10 bar (low friction)
Speed	10 ÷ 1000 mm/sec, no load (standard and low temperature); 5 ÷ 1000 mm/sec, no load (low friction)
Fluid	filtered air, without lubrication. For standard versions only: if lubricated air is used, it is recommended to use oil ISOVG32. Once applied the lubrication should never be interrupted.

STANDARD STROKES FOR CYLINDERS SERIES 61

■ = Single-acting (standard and low temperature) ✕ = Double-acting (standard, low friction and low temperature)
 Other strokes up to 2500 mm are available on request.

STANDARD STROKES														
Ø	25	50	75	80	100	125	150	160	200	250	300	320	400	500
32	■ ✕	■ ✕	■ ✕	✕	✕	✕	✕	✕	✕	✕	✕	✕	✕	✕
40	■ ✕	■ ✕	■ ✕	✕	✕	✕	✕	✕	✕	✕	✕	✕	✕	✕
50	■ ✕	■ ✕	■ ✕	✕	✕	✕	✕	✕	✕	✕	✕	✕	✕	✕
63	■ ✕	■ ✕	■ ✕	✕	✕	✕	✕	✕	✕	✕	✕	✕	✕	✕
80	■ ✕	■ ✕	■ ✕	✕	✕	✕	✕	✕	✕	✕	✕	✕	✕	✕
100		■ ✕	■ ✕	✕	✕	✕	✕	✕	✕	✕	✕	✕	✕	✕
125		✕	✕	✕	✕	✕	✕	✕	✕	✕	✕	✕	✕	✕

CODING EXAMPLE

61	M	2	P	050	A	0200	
61	SERIES						
M	VERSION M = standard, magnetic L = low friction, magnetic						
2	OPERATION 1 = single-acting, front spring (ø 32 ± ø 100) 2 = double-acting, front and rear cushioned 3 = double-acting, no cushion 4 = double-acting, rear cushioned 5 = double-acting, front cushioned 6 = double-acting, through-rod, front and rear cushioned 7 = single-acting, through-rod					PNEUMATIC SYMBOLS CS07 CD09 CD08 CD10 CD11 CD13 CS11	
P	MATERIALS P = see the general data on page 1/1.25.01 R = stainless steel AISI 420B tie-rods, stainless steel AISI 303 tie-rod nuts, others: see p. 1/1.25.01 C = rolled stainless steel AISI 303 piston rod, stainless steel AISI 304 piston rod nut U = rolled stainless steel AISI 303 piston rod, AISI 304 piston-rod nut, AISI 420B tie-rods, AISI 303 tie-rod nuts W = rolled stainless steel AISI 304 piston rod, AISI304 piston-rod nut, AISI 420B tie-rods, AISI 303 tie-rod nuts Z = chrome plated stainless steel AISI 420B rod, stainless steel AISI 304 rod nut, stainless steel AISI 420B tie-rods, stainless steel AISI 303 tie-rod nuts, seals for low temperature (-40°C), brass rod scraper [Ø 125 excepted] Y = chrome plated stainless steel AISI 420B rod, stainless steel AISI 304 rod nut, stainless steel AISI 420B tie-rods, stainless steel AISI 303 tie-rod nuts, seals for low temperature (-50°C), brass rod scraper [Ø 125 excepted]						
050	BORE 032 = 32 mm - 040 = 40 mm - 050 = 50 mm - 063 = 63 mm - 080 = 80 mm - 100 = 100 mm - 125 = 125 mm						
A	CONSTRUCTION A = standard with rod nut - RL = cylinder with rod lock						
0200	STROKE (see the table)						
	= standard V = FKM rod seal N = tandem R = NBR rod seal W = all FKM seals +130C° C = PU coated cylinder. Colour: Grey * L = low friction version without rod seal (rear supply only) ** (_ _ _) = extended piston rod _ _ _ mm G = with brass rod scraper (chrome plated stainless steel AISI 420B rod, NBR rod seal) [Ø 125 excepted] * Version C: available on request. For further information, please contact our technical dept. ** The possibility to order the cylinder without piston rod seal, further reduces the friction force.						

Note: all double-acting cylinders are also available in the low friction version.

PNEUMATIC SYMBOLS

The pneumatic symbols which have been indicated in the CODING EXAMPLE are shown below.

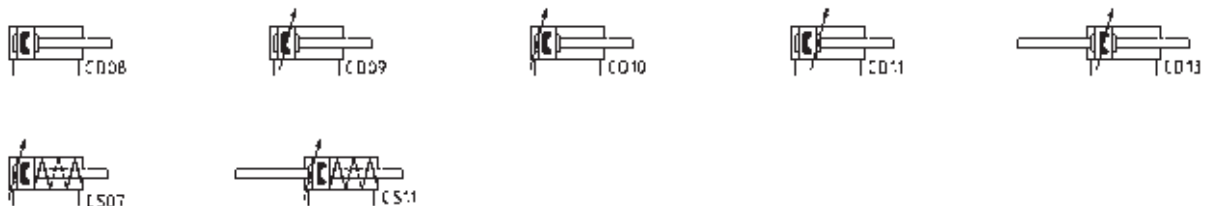

Low friction cylinders Series 61 - APPLICATION EXAMPLES

1

MOVEMENT

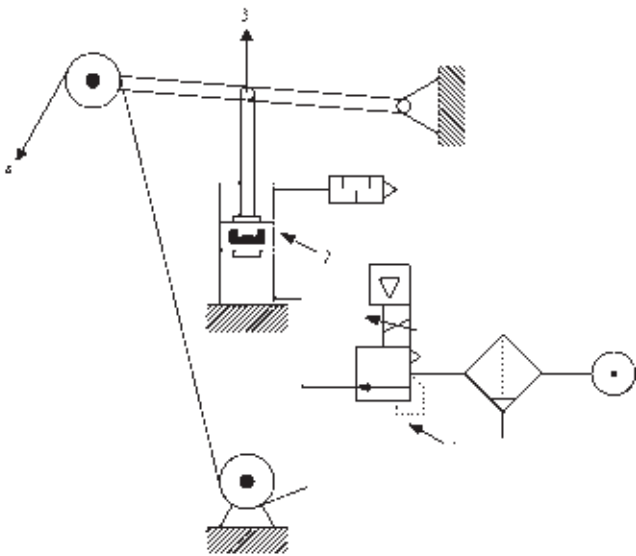

CYLINDER IN THRUST

DRAWING NOTES:

1. Precision pressure regulator or electro-pneumatic regulator
2. Low friction cylinder
3. Force direction
4. Band

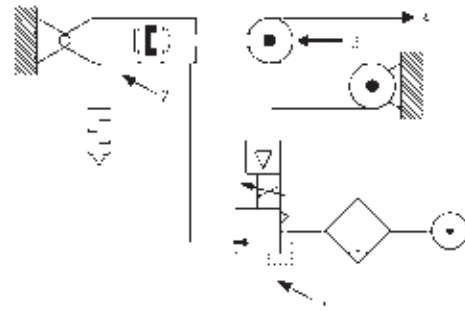

CYLINDER IN TRACTION

Note: in order to reach the highest performance, it is recommended to connect precision pressure regulator or an electro-pneumatic regulator with the low friction cylinder as shown in the drawing.

Low temperature cylinders Series 61 - DETAIL

New version

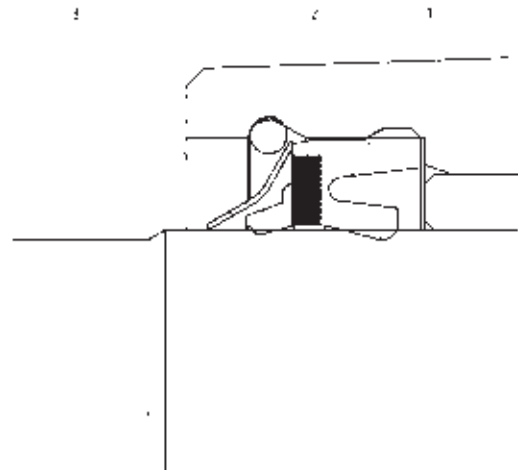

- 1 = rod seal
- 2 = seeger
- 3 = metal scraper

CYLINDERS ACCESSORIES SERIES 61



Piston rod socket joint
Mod. GY



Piston rod lock nut
Mod. U



Clevis pin Mod. S



Rear trunnion ball-joint
Mod. R



Coupling piece
Mod. GKF



Swivel ball joint Mod. GA



90° male trunnion
Mod. ZC



Swivel Combination
Mod. C+L+S



Front and rear flange
Mod. D-E



Self aligning rod
Mod. GK



Centre trunnion Mod. F



Foot mount Mod. B



Front female trunnion
Mod. H and C-H



Rear female trunnion
Mod. C and C-H



Rod fork end Mod. G



Rear trunnion male Mod.
L



Key to disassemble cylin-
ders Ø 80 and 100



All accessories are supplied separately, except for piston rod lock nut Mod. U

Cylinders Series 61

N.B. : the single-acting cylinders, sizes ZJ and L2 are increased by 25 mm.



+ = add the stroke

Table note:
* = special key 80-62/8C
(see accessories)

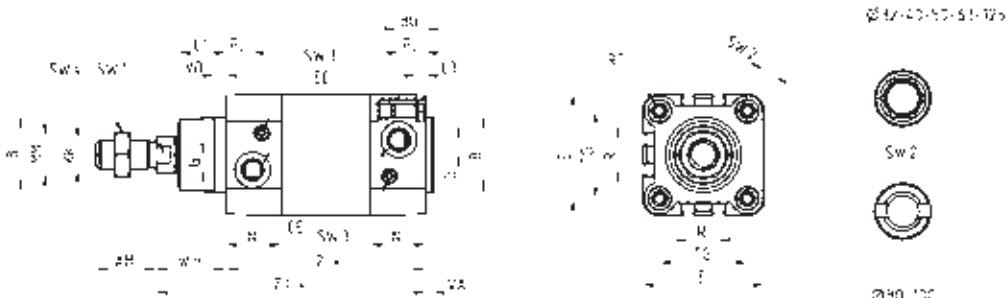

DIMENSIONS																									
Ø	AM	B	BG	E	EE	G	KK	L1	L2+	L3	MM	N	PL	R	RT	SW1	SW2	SW3	SW4	TG	VA	VD	WH	ZJ+	front/rear cushion stroke
32	22	30	16	46	G1/8	5	M10x1,25	18	94	5	12	26	14	13	M6	10	6	2	17	32,5	4	5	26	120	17 / 12
40	24	35	16	55	G1/4	5	M12x1,25	21	105	5	16	29	15	13,5	M6	13	6	2	19	38	4	5	30	135	20 / 17
50	32	40	16	64,5	G1/4	8	M16x1,5	25	106	5	20	29,5	15	16	M8	17	8	3	24	46,5	4	6	37	143	15 / 14
63	32	45	16	75	G3/8	8	M16x1,5	26	121	5	20	36,5	21	28	M8	17	8	3	24	56,5	4	6	37	158	17 / 16
80	40	45	19	93	G3/8	8	M20x1,5	30	128	0	25	36	21	30	M10	22	*	5	30	72	4	7	46	174	20 / 20
100	40	55	19,5	110	G1/2	8	M20x1,5	35	138	0	25	38,5	23	40	M10	22	*	5	30	89	4	7	51	189	21 / 19
125	54	60	23	135	G1/2	10,5	M27x2	42	160	0	32	43	23,5	50	M12	27	12	4	41	110	6	8	65	225	26 / 25

Cylinders Series 61 - through-rod

Note: the single-acting cylinders sizes ZM and L2 are increased by 25 mm.



+ = add the stroke once
++ = add the stroke twice

Table note:
* = special key 80-62/8C
(see accessories)

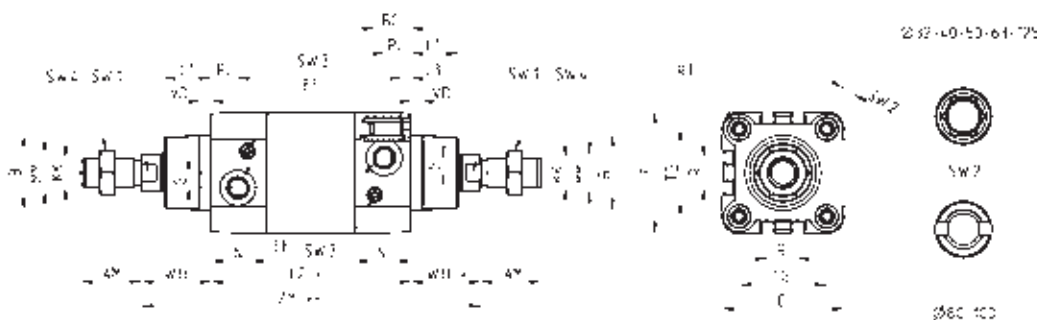

DIMENSIONS																								
Ø	AM	B	BG	E	EE	G	KK	L1	L2+	L3	MM	N	PL	R	RT	SW1	SW2	SW3	SW4	TG	VD	WH	ZM++	front/rear cushion stroke
32	22	30	16	46	G1/8	5	M10x1,25	18	94	5	12	26	14	13	M6	10	6	2	17	32,5	5	26	146	17 / 12
40	24	35	16	55	G1/4	5	M12x1,25	21	105	5	16	29	15	13,5	M6	13	6	2	19	38	5	30	165	20 / 17
50	32	40	16	64,5	G1/4	8	M16x1,5	25	106	5	20	29,5	15	16	M8	17	8	3	24	46,5	6	37	180	15 / 14
63	32	45	16	75	G3/8	8	M16x1,5	26	121	5	20	36,5	21	28	M8	17	8	3	24	56,5	6	37	195	17 / 16
80	40	45	19	93	G3/8	8	M20x1,5	30	128	0	25	36	21	30	M10	22	*	5	30	72	7	46	220	20 / 20
100	40	55	19,5	110	G1/2	8	M20x1,5	35	138	0	25	38,5	23	40	M10	22	*	5	30	89	7	51	240	21 / 19
125	54	60	23	135	G1/2	10,5	M27x2	42	160	0	32	43	23,5	50	M12	27	12	4	41	110	8	65	290	26 / 25

Cylinders Series 61 - tandem version



+ = add the stroke once
 ++ = add the stroke twice

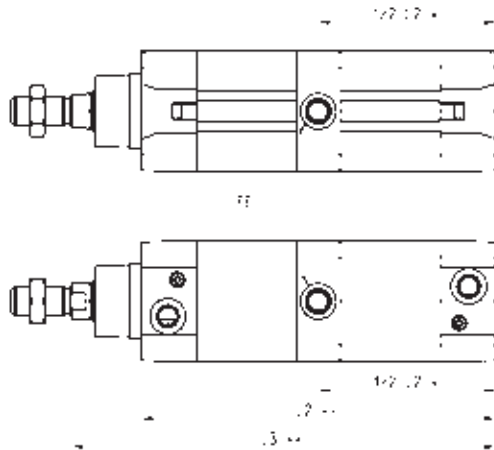

DIMENSIONS				
Ø	EE	L2+	L3+	
32	G1/8	172,5	197,5	
40	G1/4	191,5	221,5	
50	G1/4	188	225	
63	G3/8	204	241	
80	G3/8	225,5	271,5	
100	G1/2	231	282	
125	G1/2	264	329	

Cylinders Series 61 with rod lock



+ = add the stroke

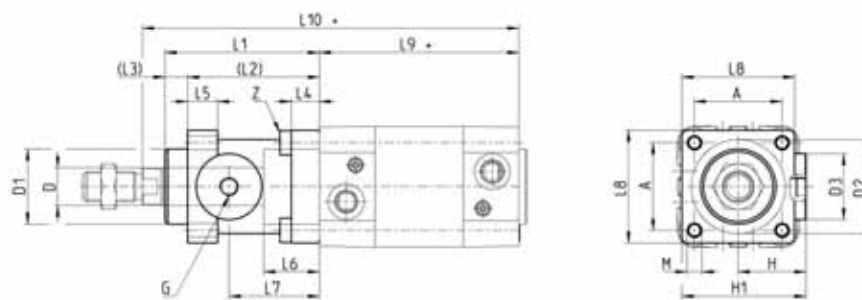

DIMENSIONS																					
Ø	øD	øD1	øD2	øD3	A	G	H	H1	L1	L2	L3	L4	L5	L6	L7	L8	L9+	L10+	M	Z	
32	12	30.5	35	25	32,5	M5	25,5	46,5	58	48	10	8	13	20,5	34	45	94	160	M6	M6x20	
40	16	35	40	28	38	G1/8	30	53	65	55	10	8	13	22,5	38	50	105	178	M6	M6x20	
50	20	40	50	35	46,5	G1/8	36	64	82	70	12	15	16	29,5	48	60	106	200	M8	M6x20	
63	20	45	60	38	56,5	G1/8	40	75	82	70	12	15	16	29,5	49,5	70	121	215	M8	M8x30	
80	25	45	80	48	72	G1/8	50	95	110	90	20	18	20	35	61	90	128	254	M10	M10x35	
100	25	55	100	58	89	G1/8	58	110,5	115	100	15	18	20	39	69	105	138	269	M10	M10x35	
125	32	60	130	65	110	G1/8	80	150	167	122	45	22	30	51	86,5	140	160	350	M12	M12x40	

Foot mount Mod. B

Material: zinc-plated steel

 Supplied with:
 2x feet
 4x screws

+ = add the stroke

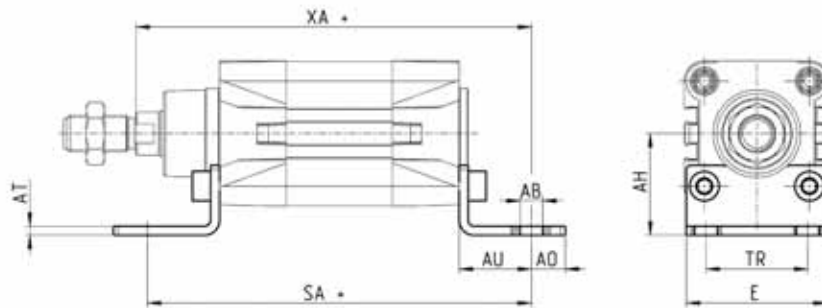
DIMENSIONS

Mod.	Ø	AT	SA+	XA+	TR	E	AB	AH	AO	AU
B-41-32	32	4	142	144	32	45	7	32	11	24
B-41-40	40	4	161	163	36	53,5	10	36	15	28
B-41-50	50	4	170	175	45	62,5	10	45	15	32
B-41-63	63	5	185	190	50	73	10	50	15	32
B-41-80	80	6	210	216	63	92	12	63	20	41
B-41-100	100	6	220	230	75	108,5	14,5	71	25	41
B-41-125	125	7	250	270	90	132	16,5	90	25	45

Front and rear flange Mod. D-E

Material: Aluminium

 Supplied with:
 1x flange
 4x screws

+ = add the stroke

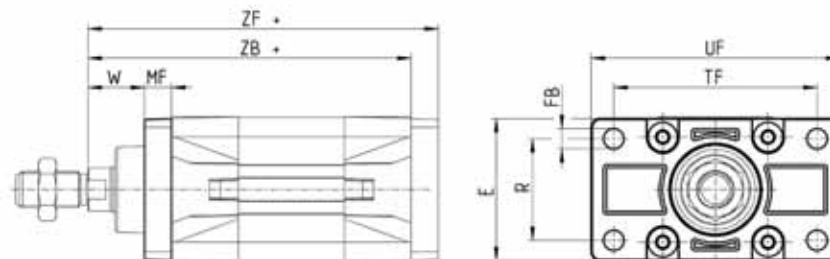
DIMENSIONS

Mod.	Ø	W	MF	ZB+	TF	R	UF	E	FB	ZF+	torque force
D-E-41-32	32	16	10	120	64	32	86	45	7	130	6 Nm
D-E-41-40	40	20	10	135	72	36	88	52	9	145	6 Nm
D-E-41-50	50	25	12	143	90	45	110	63	9	155	13 Nm
D-E-41-63	63	25	12	158	100	50	116	73	9	170	13 Nm
D-E-41-80	80	30	16	174	126	63	148	95	12	190	19 Nm
D-E-41-100	100	35	16	189	150	75	176	115	14	205	22 Nm
D-E-41-125	125	45	20	225	180	90	224	135	16	245	26 Nm

Rear female trunnion Mod. C and C-H

Material: Aluminium



Supplied with:
1x female trunnion
4x screws

+ = add the stroke

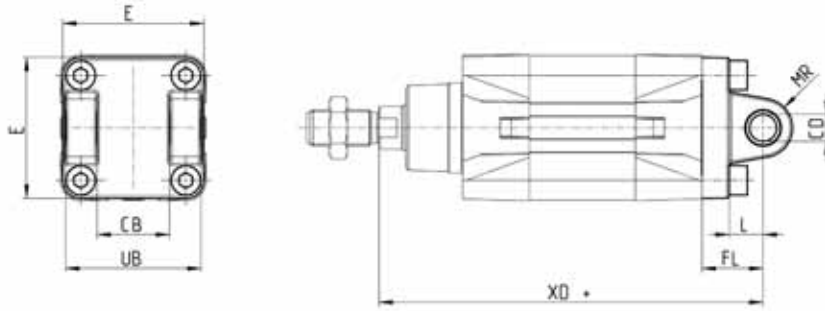

DIMENSIONS

Mod.	∅	CD	L	FL	XD+	MR	E	CB	UB	torque force
C-41-32	32	10	12	22	142	10	45	26	45	6 Nm
C-41-40	40	12	15	25	160	13	52	28	52	6 Nm
C-41-50	50	12	15	27	170	13	63	32	60	13 Nm
C-H-41-63	63	16	20	32	190	15	73	40	70	13 Nm
C-H-41-80	80	16	24	36	210	15	95	50	90	19 Nm
C-H-41-100	100	20	29	41	230	18	115	60	110	22 Nm
C-H-41-125	125	25	30	50	275	25	135	70	130	26 Nm

Front female trunnion Mod. H and C-H

Material: Aluminium



Supplied with:
1x female trunnion
4x screws

+ = add the stroke

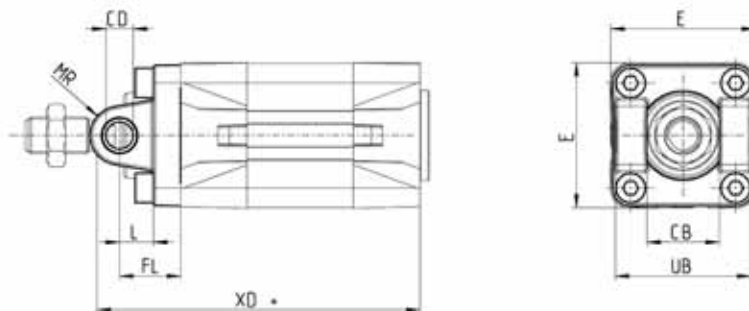

DIMENSIONS

Mod.	∅	CB	UB	E	XD	FL	L	CD	MR
H-41-32	32	26	45	45	120	22	12	10	10
H-41-40	40	28	52	52	135	25	15	12	13
H-41-50	50	32	60	63	143	27	15	12	13
H-60-63	63	40	70	73	158	32	20	16	15
C-H-41-80	80	50	90	95	174	36	24	16	15
C-H-41-100	100	60	110	115	189	41	29	20	18
C-H-41-125	125	70	130	135	225	50	30	25	25

Rear male trunnion Mod. L

Material: Aluminium



Supplied with:
1x male trunnion
4x screws

+ = add the stroke

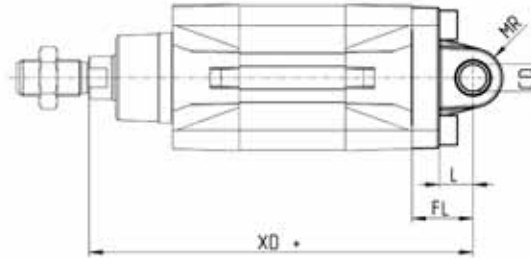
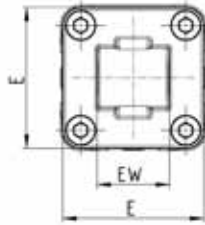

DIMENSIONS

Mod.	∅	CD	L	FL	XD+	MR	E	EW	torque force
L-41-32	32	10	12	22	142	9	45	26	6 Nm
L-41-40	40	12	15	25	160	13	52	28	6 Nm
L-41-50	50	12	15	27	170	13	63	32	13 Nm
L-41-63	63	16	20	32	190	15	73	40	13 Nm
L-41-80	80	16	24	36	210	15	95	50	19 Nm
L-41-100	100	20	29	41	230	18	115	60	22 Nm
L-41-125	125	25	30	50	275	25	135	70	26 Nm

Centre trunnion Mod. F

Material: zinc-plated steel



Supplied with:
1x centre trunnion
4x screws
4x fixing elements

+ = add the stroke

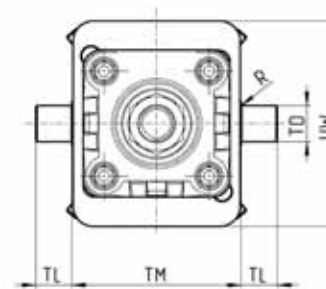
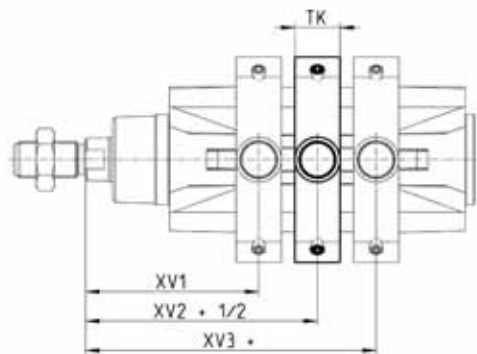

DIMENSIONS

Mod.	∅	XV1	XV2	XV3	TM	TK	TD	TL	UW	R
F-61-32	32	61	73	85	50	18	12	12	65	0,1
F-61-40	40	69	82,5	96	63	20	16	16	75	0,15
F-61-50	50	76,5	90	103,5	75	20	16	16	91	0,15
F-61-63	63	86	97,5	109	90	25	20	20	94	0,15
F-61-80	80	94,5	110	125,5	110	25	20	20	130	0,15
F-61-100	100	104,5	120	135,5	132	30	25	25	145	0,2
F-61-125	125	123	145	167	160	30	25	25	155	0,2

Accessory combination Mod. C+L+S

Material: aluminium



+ = add the stroke

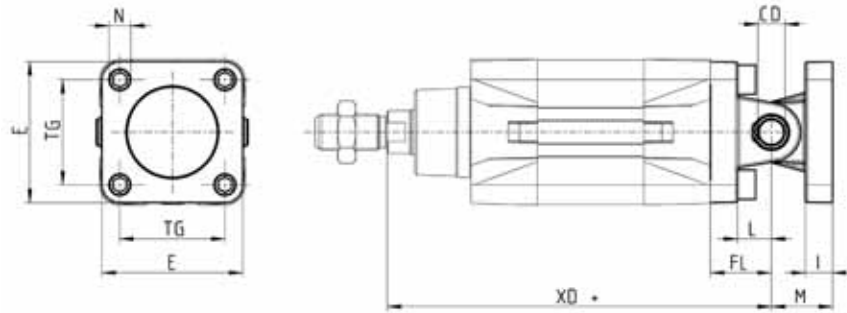

DIMENSIONS											
Mod.	∅	∅CD	L	FL	XD+	TG	E	I	M	∅N	torque force
C+L+S	32	10	12	22	142	32,5	45	10	22	6,5	6 Nm
C+L+S	40	12	15	25	160	38	52	10	25	6,5	6 Nm
C+L+S	50	12	15	27	170	46,5	63	13	27	9	13 Nm
C+L+S	63	16	20	32	190	56,5	73	15	32	9	13 Nm
C+L+S	80	16	24	36	210	72	95	15	36	11	19 Nm
C+L+S	100	20	29	41	230	89	115	18	41	11	22 Nm
C+L+S	125	25	30	50	275	110	135	25	50	13	26 Nm

90° male trunnion Mod. ZC

CETOP RP 107P
Material: Aluminium



Supplied with:
1x male support

+ = add the stroke

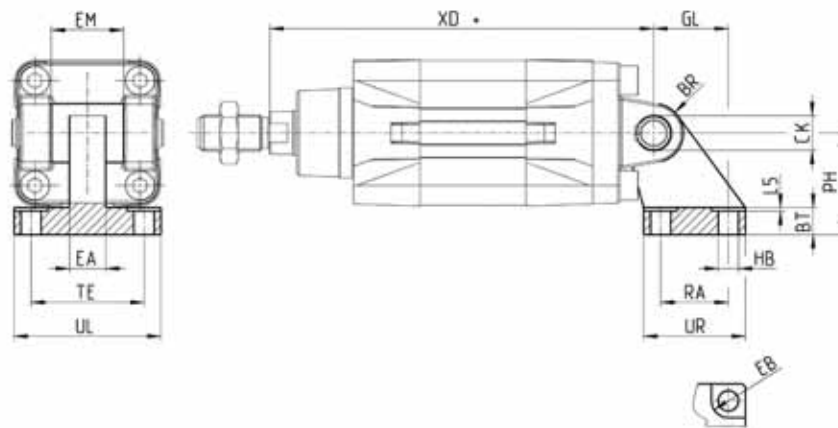

DIMENSIONS																
Mod.	∅	EB	CK	HB	XD+	TE	UL	EA	GL	L5	RA	EM	UR	PH	BT	BR
ZC-32	32	11	10	6,6	142	38	51	10	21	1,6	18	26	31	32	8	10
ZC-40	40	11	12	6,6	160	41	54	15	24	1,6	22	28	35	36	10	11
ZC-50	50	15	12	9	170	50	65	16	33	1,6	30	32	45	45	12	13
ZC-63	63	15	16	9	190	52	67	16	37	1,6	35	40	50	50	14	15
ZC-80	80	18	16	11	210	66	86	20	47	2,5	40	50	60	63	14	15
ZC-100	100	18	20	11	230	76	96	20	55	2,5	50	60	70	71	17	19
ZC-125	125	20	25	14	275	94	124	30	70	3,2	60	70	90	90	20	22,5

Trunnion ball-joint Mod. R*

 Material: Aluminium
 * not according to standard

 Supplied with:
 1x trunnion ball joint
 4x screws

+ = add the stroke

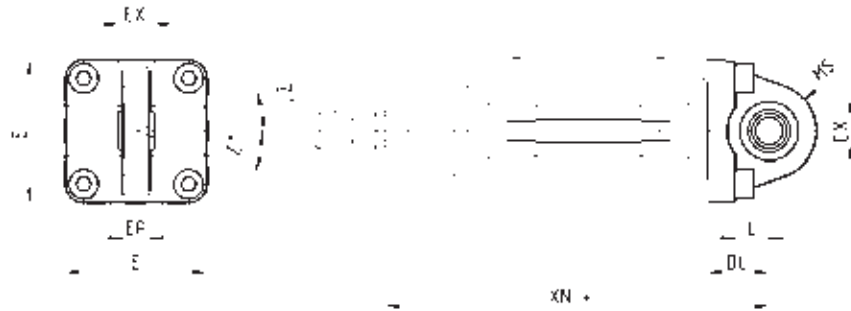
DIMENSIONS

Mod.	Ø	CX	L	DL	XN+	MS	E	EX	EP	Z	torque force
R-41-32	32	10	12	22	142	16	45	14	10,5	4	6 Nm
R-41-40	40	12	15	25	160	20	52	16	12	4	6 Nm
R-41-50	50	12	15	27	170	20	63	16	12	4	13 Nm
R-41-63	63	16	20	32	190	24	73	21	15	4	13 Nm
R-41-80	80	16	24	36	210	24	95	21	15	4	19 Nm
R-41-100	100	20	29	41	230	30	115	25	18	4	22 Nm
R-41-125	125	30	30	50	275	40	140	37	25	4	26 Nm

Counter bracket for centre trunnion Mod. BF

Material: Aluminium

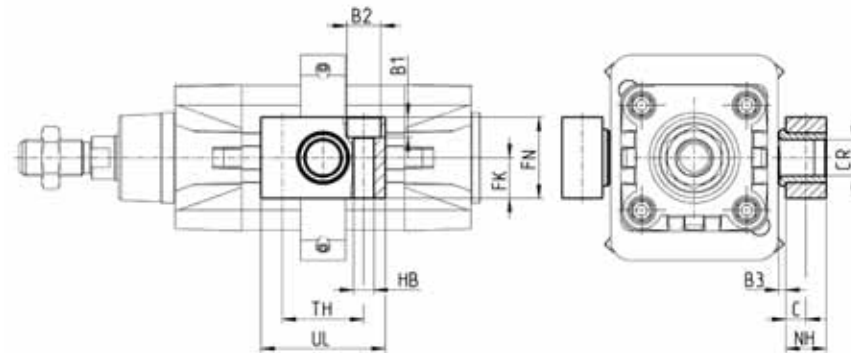
 Supplied with:
 2x supports

DIMENSIONS

Mod.	Ø	CR	NH	C	B3	TH	UL	FK	FN	B1	B2	HB
BF-32	32	12	15	7,5	3	32	46	15	30	6,8	11	6,6
BF-40-50	40 - 50	16	18	9	3	36	55	18	36	9	15	9
BF-63-80	63 - 80	20	20	10	3	42	65	20	40	11	18	11
BF-100-125	100 - 125	25	25	12,5	3,5	50	75	25	50	13	20	14

Accessory to mount valves on the cylinder

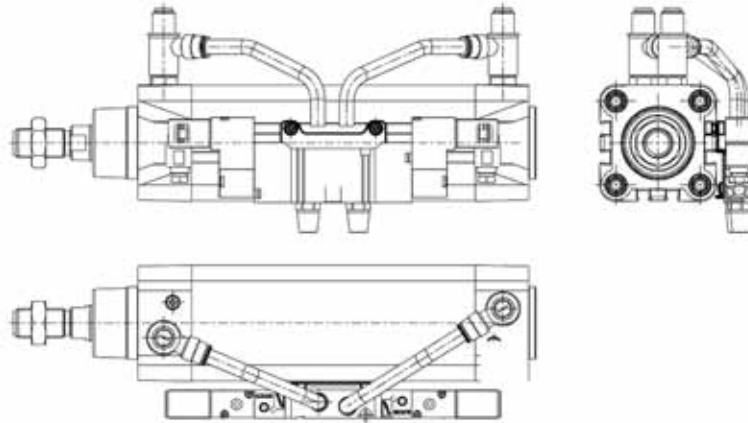
The mounting sub-base Mod. PCV enables the valve or solenoid valve to be mounted directly on the cylinder.



1
MOVEMENT

DIMENSIONS

Mod.	
PCV-61-K3	to connect valves - solenoid valves Series 3
PCV-61-K4	to connect valves - solenoid valves Series 4 port G1/4
PCV-62-KEN	to connect valves - solenoid valves Series EN
PCV-61-K8	to connect valves - solenoid valves Series 4 port G1/8 and Series 3 port G1/4

Clevis pin Mod. S



Supplied with:
1x clevis pin in stainless steel 303
2x Seeger in steel

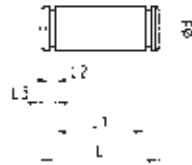

DIMENSIONS

Mod.	Ø	d	L	L1	L2	L3
S-32	32	10	52	46	1,1	3
S-40	40	12	59	53	1,1	3
S-50	50	12	67	61	1,1	3
S-63	63	16	77	71	1,1	3
S-80	80	16	97	91	1,1	3
S-100	100	20	121	111	1,3	5
S-125	125	25	140,5	132	1,3	4,25

Swivel ball joint Mod. GA

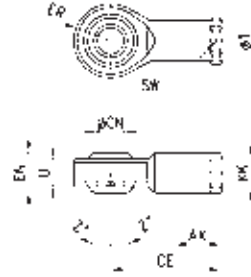
 ISO 8139.
 Material: zinc-plated steel.

DIMENSIONS

Mod.	øCN	U	EN	ER	AX	CE	KK	T	Z	SW
GA-32	10	10,5	14	14	20	43	M10X1,25	15	6,5	17
GA-40	12	12	16	16	22	50	M12X1,25	17,5	6,5	19
GA-50-63	16	15	21	21	28	64	M16X1,5	22	7,5	22
GA-80-100	20	18	25	25	33	77	M20x1,5	27,5	7	30
GA-41-125	30	25	37	37	51	110	M27x2	40	7,5	41

Piston rod socket joint Mod. GY

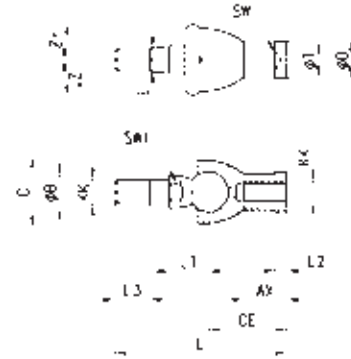
Material: zama and zinc-plated steel.

DIMENSIONS

Mod.	Ø	KK	L	CE	L2	AX	SW	SW1	L1	L3	øT	øD	E	øB	øC	Z	
GY-32	32	M10X1,25	74	35	6,5	18	17	11	19,5	15	15	15	19	10	14	28	15
GY-40	40	M12X1,25	84	40	6,5	20	19	17	21	17	17,5	22	12	19	32	15	
GY-50-63	50-63	M16X1,5	112	50	8	27	22	19	27,5	23	22	27	16	22	40	11	
GY-80-100	80-100	M20x1,5	133	63	10	38	30	24	31,5	25	27,5	34	20	27	45	7,5	

Rod fork end Mod. G

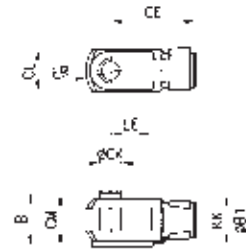
 ISO 8140
 Material: zinc-plated steel

DIMENSIONS

Mod.	øCK	LE	CM	CL	ER	CE	KK	B	B1
G-25-32	10	20	10	20	12	40	M10 X 1,25	26	18
G-40	12	24	12	24	14	48	M12 X 1,25	32	20
G-50-63	16	32	16	32	19	64	M16 X 1,5	40	26
G-80-100	20	40	20	40	25	80	M20 X 1,5	48	34
G-41-125	30	54	30	55	38	110	M27 X 2	74	48

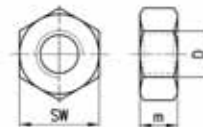
Piston rod lock nut Mod. U

 ISO 4035
 Material: zinc-plated steel.

DIMENSIONS

Mod.	D	m	SW
U-25-32	M10X1,25	6	17
U-40	M12X1,25	7	19
U-50-63	M16X1,5	8	24
U-80-100	M20x1,5	9	30
U-41-125	M27x2	12	41

