

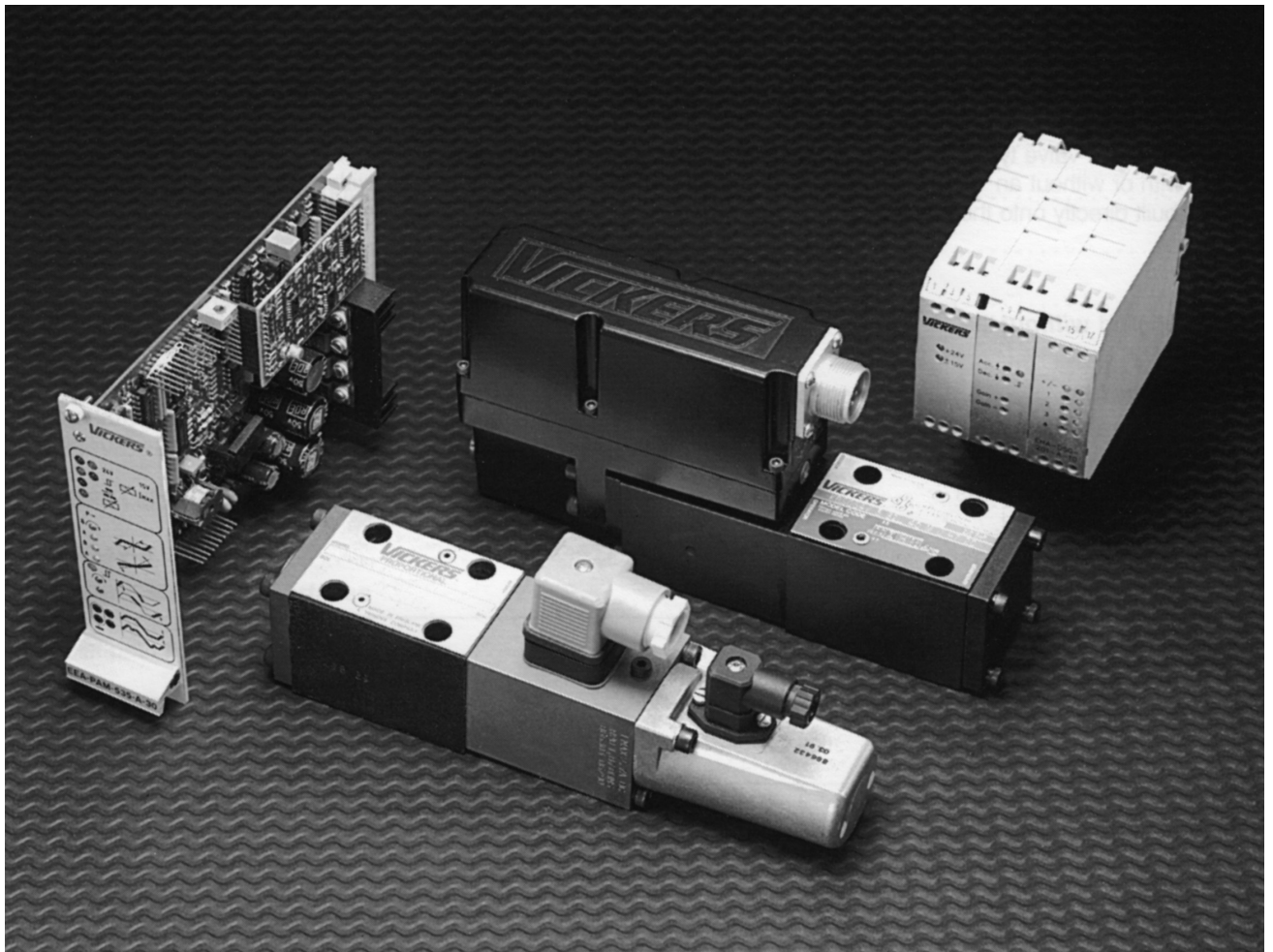

Electrohydraulic Controls Proportional Directional Valves with Feedback

Technical Catalog

K(B)FD/TG4V-3, 1*/2* Series
Pressures to 350 bar (5000 psi)



Electrohydraulic Controls

Contents

Introduction		3
Typical Section View		3
Model Code		4
Spool Data		5
Functional Symbols		
Operating Data	Valves with Amplifier Kbfd/TG4V-3	6
	Valves without Amplifier Kfd/TG4V-3 Kbfd/TG4V-3 & Kfd/TG4V-3	7
Performance Curves	Power Capacity Envelopes, Single Solenoid Models	8
	Power Capacity Envelopes, Double Solenoid Models	
	Flow Gain Curves	9
	Frequency Response	
Installation Dimensions	KFDG4V-3	10
	KFTG4V-3	10
	KBFDG4V-3	11
	KBFTG4V-3	11
Subplates and Mounting Surfaces	Parallel Path Flow Module	12
	Subplate Functional Symbol	
	Interface with Additional Drain Port	
	Installation Dimensions, Single Station Subplate KDGVM-3-1*-R	13
	Installation Dimensions, Single Station Subplate KDGVM-3-676803-1*	
	Mounting Surface Interface to ISO 4401 (Size 03)	
Electrical Information	Block Diagram	14
	Wiring Connection	16
Application Data		18

Introduction

General Description

Vickers proportional valves shown in this catalog are designed to provide a controlled oil flow in direct proportion to a command signal. They are available in two types; a double solenoid version that will provide reversible flow to an actuator and a single solenoid throttle version that provides a single direction of flow. Hydrostats are available for load compensation and parallel flow path modules are available that will boost the flow capacity of single solenoid throttle versions to nearly twice that of the standard valve.

Additionally, both of these valve types can be supplied with or without an integral amplifier built directly onto the valve.

KFD/TG4V-3

This version is supplied **without** the integral amplifier.

Features and Benefits

- Wide range of spool and flow rate options
- Electronic feedback LVDT ensures accurate spool position control
- Vibration and shock tested
- Supported by a broad range of amplifiers and auxiliary function modules
- Full CE electromagnetic compatibility

KBFD/TG4V-3

A range of proportional directional and throttle valves **with** integral control electronics. Factory-set adjustments of gain, spool deadband compensation and offset ensure consistent repeatability valve-to-valve.

The only electrical inputs required are power supply (24V) and a voltage command signal of $\pm 10V$ or 4-20 mA. The amplifier is housed in a robust metal enclosure, sealed against ingress of water and other fluids. Electrical connections are via a standard 7-pin plug.

A spool position monitor pin allows the function of the valve to be electrically monitored. Ramp functions, if required, can be generated externally.

Features and Benefits

- Factory-sealed adjustments ensure valve-to-valve reproducibility

- Installation wiring reduced and simplified
- Standard 7-pin connector
- Standard 24V DC supply with wide tolerance band
- Optional $\pm 10V$ DC or 4-20 mA command signals
- Valve with integrated amplifier selected, ordered, delivered and installed as one performance-tested package
- Spool position monitor pin to help with troubleshooting
- Simple valve removal and replacement for service (plug and play)
- Vibration and shock tested
- Auxiliary DIN rail mounted electronic function modules available
- Full CE electromagnetic compatibility
- IP65 and IP67 valve environmental protection rating
- Optional valve enable function

Typical Section View

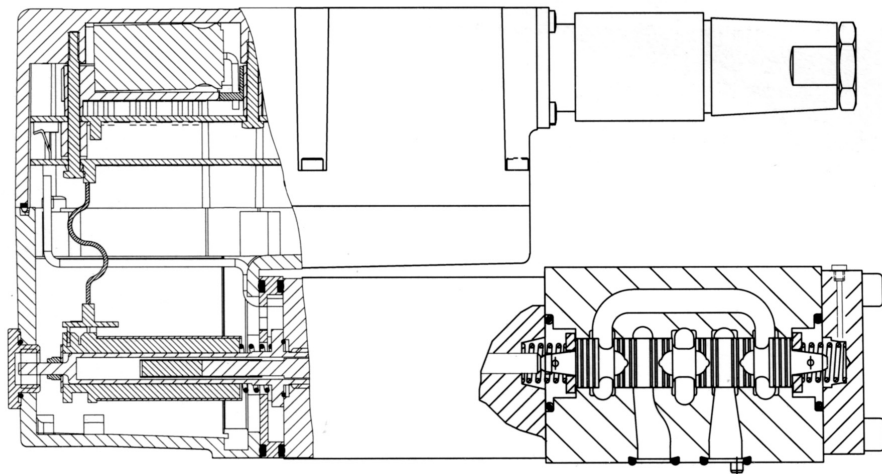

KBFD/TG4V-3-*C, 1* Design

Model Codes

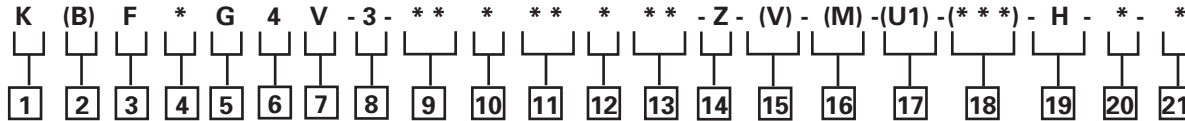

1 Valve Type

K Proportional valve

2 Integral Amplifier

B Integral amplifier "B" series. Omit for models without integral amplifier

3 Feedback Arrangement

F Spool position

4 Control Type

D Directional valve

T Throttle valve

5 Mounting

G Subplate mounted

6 Operation

4 Solenoid operation

7 Pressure Rating

V 350 bar (5000 psi) on ports P, A & B

8 Interface

3 ISO 4401, size 03-02-0-94 ANSI/B93.7M-D03

9 Spool Type (center condition) (see spool data, page 5)

2 All ports closed

5 All ports closed (zero lap)

33 P port closed, bleed A & B to T

10 Spool/Spring Arrangement

B Spring centered single solenoid valve (solenoid "B" only) Solenoid "A" for "V" version, Throttle valve

C Spring centered, dual solenoid, Direction valve

11 Spool Flow Rating

$\Delta p = 5$ bar (75 psi) per metering flow path, e.g. B to T. (For actual maximum flow refer to power capacity envelope curves.

03 3 L/min (0.79 USgpm) Δ

07 7 L/min (1.85 USgpm) \blacktriangle

13 13 L/min (3.43 USgpm) \blacktriangle

20 20 L/min (5.28 USgpm) \blacktriangle

28 28 L/min (7.40 USgpm) \square

30 30 L/min (7.92 USgpm) \blacksquare

\blacktriangle Meter-in/meter-out

\square Meter-out only; type 2 spool only

Δ Fine meter-in/meter-out

\blacksquare 5C Spool only

12 Spool Metering Type

N Meter-in and meter-out

F Fine meter-in and meter-out (only 03 spool)

S Meter-out only

13 Flow Rating ("B" port flow for asymmetric spools) K(B)FDG Valves only

10 10 L/min (2.64 USgpm) (20N10 only)

Omit for symmetrical spools

14 Manual Overrides

Z No manual overrides

15 Solenoids Energization Identity

(non-integral amplifier types KF only, omit for valves with integral amplifier)

V Solenoid "A" is at port "A" end and Solenoid "B" is at port "B" end independent of spool type

Blank US ANSI B93.9 standard (energize solenoid "A", flow symbol is (P→A))

16 Command Input

M Electrical feature flag (KF only)

M1 \pm 10VDC (KBF only)

M2 4-20 mA (KBF only)

17 Solenoid Connector

Omit for valves with integral amplifier KBF

U1 ISO 4400/DIN 43650, non-integral amplifier type KF only (mating plug supplied)

18 Electrical Connection (KBF valves only)

PC7 7-pin connector without plug

PE7 7-pin electrical plug with mating half

PH7 As PE7 but with pin "C" used for enable signal

PR7 As PC7 but with pin "C" used for enable signal

19 Coil Rating

H 24 VDC amplifier supply

20 Port T Pressure Limit Code

6 For 2C**S spools

7 For all other spools

21 Design Number

1* & 2* Series

Subject to change



WARNING

Valves with integral amplifier are supplied with or without the metal 7-pin plug. The Vickers plug, part no. 934939, must be correctly fitted to ensure that the EMC rating and IP67 rating are achieved. The plug retaining nut must be tightened with a torque of 2-2.5 Nm (1.5-2.0 lbf ft) to effect a proper a proper seal)

Spool Data

Spool Symbols

Available Spools for K(B)FDG4V-3

Spool type 2C**N, meter-in/meter-out

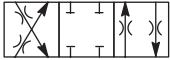

Spool type 5C**N, meter-in/meter-out (zero lap)

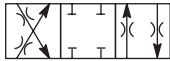

Spool type 2C20N10, asymmetric flow

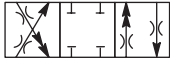

Spool type 2C28S, meter-out only

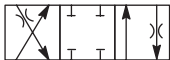

Spool 33C**N, meter-in/meter-out

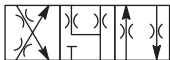

Spool type 33C20N10, asymmetric flow

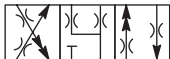

Available Spools for K(B)FTG4V-3

Spool type 2B**N, meter-in/meter-out



Functional Symbols

Model Types Kbfdg4v-3

proportional directional valve (with integrated electronics)

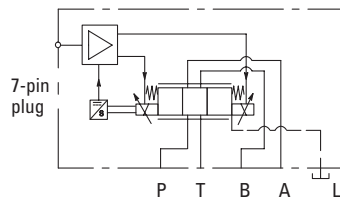

Model Types Kfdg4v-3

proportional directional valve (requires amplifier card)

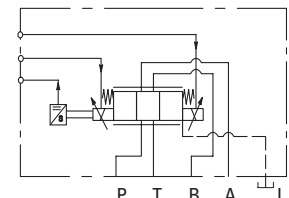

Model Types Kbftg4v-3

proportional throttle valve (with integrated electronics)

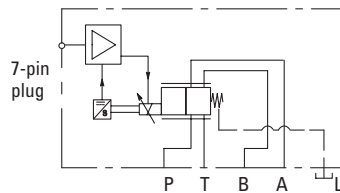

Model Types Kftg4v-3

proportional throttle valve (requires amplifier card)

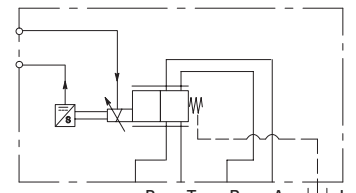

Spool Type and Flow Rating

Symmetric Spools

Base line starting at $\Delta p = 5$ bar (75 psi) per metering flow pat, e.g. B to T. For actual maximum flow refer to power capacity envelope curves.

FOR K(B)FDG4V-3 VALVES

Spool Code	Spool Symbol	Flow Rating
2C03F	2C	3 L/min (0.79 USgpm)
2C07N	2C	7 L/min (1.85 USgpm)
2C13N	2C	13 L/min (3.43 USgpm)
2C20N	2C	20 L/min (5.28 USgpm)
2C30N	2C	30 L/min (7.92 USgpm)
2C28S	2C	28 L/min (7.40 USgpm)
33C03F	33C	3 L/min (0.79 USgpm)
33C07N	33C	7 L/min (1.85 USgpm)
33C13N	33C	13 L/min (3.43 USgpm)
33C20N	33C	20 L/min (5.28 USgpm)
5C30N	5C	30 L/min (7.92 USgpm)

FOR K(B)FTG4V-3 VALVES

Spool Code	Spool Symbol	Flow Rating
2B03F	2B	03 L/min (0.79 USgpm)
2B07N	2B	07 L/min (1.85 USgpm)
2B13N	2B	13 L/min (3.43 USgpm)
2B20N	2B	20 L/min (5.28 USgpm)

Asymmetric Spools

Figure preceding metering type designator, "N" (e.g. 2C**N) is flow rating P-A, or A-T ("A" port flow); figure after "N" (N**) is flow rating P-B, or B-T ("B" port flow).

FOR K(B)FDG4V-3 VALVES

Spool Code	Spool Symbol	Flow Rating
2C20N10	2C	20 L/min (5.28 USgpm), "A" port flow 10 L/min (2.64 USgpm), "B" port flow
33C20N10	33C	20 L/min (5.28 USgpm), "A" port flow 10 L/min (2.64 USgpm), "B" port flow

Operating Data

K(B)FD/TG4V-3

Valves with Amplifier

KBFD/TG4V-3 VALVES WITH INTEGRAL AMPLIFIER

Data is typical with fluid at 36 cSt (168 SUS) and 50° C (122° F).

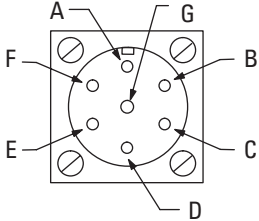
Power supply		24V DC (21 V to 36V including 10% peak-to-peak max. ripple) max current 3A
Command signal		
Voltage mode M1		0 to +10V DC, or 0 to -10V DC, or -10V to +10V DC
Current mode M2		4-20 mA
Input impedance		47 Ω
Common mode voltage to pin B		18V (max)
Input impedance		100 Ω
Max differential voltage to pin E to pin D		100 mV
Valve enable signal for model codes PH7 & PR7		
Enable		>8.5V (36V max)
Disable		<6.5 V
Input impedance		10 Ω
7-pin plug connector		Pin Description
View of pins of fixed half		
		A Power supply positive (+)
		B Power Supply 0V and current command return
		C Not connected (PE7 & PC7)
		D Command signal (+V or current IN)
		E Command signal (-V or current GND)
		F Mounting input
		G Protective ground
Electromagnetic compatibility (EMC)		
Emmission (10V/m)		EN 61326-2
Immunity (10V/m)		EN 61326-2
Threshold command voltage (minimum voltage for minimum flow)		0.25V
Monitor signal (pin F)	KBFD valves KBFT valves	± 10V DC for full spool stroke 0 to -10 V DC for full spool stroke
Output impedance		10 Ω
Power stage PWM frequency		10 kHz nominal
Step input response with flow through P-A-B-T		
Δ p=5 bar (75 psi) per metering path, e.g. P-A		
Required flow step:		Time to reach 90% of required step:
0 – 100%		17 ms
100% – 0		16 ms
+90 – -90% (KBFDG4V-3 only)		25 ms
Reproducibility, valve-to-valve (at factory settings):		
Flow at 100% command signal		≤ 5%
Protection		
Electrical		Reverse polarity protected
Environmental		I EC 60529, Class IP65 and IP67
Ambient air temperature range for full performance		0° C to 70° C (32° F to 158° F)
Oil temperature range for full performance		0° C to 70° C (32° F to 158° F)
Minimum temperature at which valves will work at reduced performance		-20° C (-4° F)
Storage temperature range		-25° C to +85° C (-13° F to +185° F)
Supporting products		
Auxiliary electronic modules (DIN -rail mounting):		
EHD-DSG-201-A-1* command signal generator		See catalog GB 2470
EHA-RMP-201-A-2* Ramp generator		See catalog GB 2410A
EHA-PID-201-A-2* PID controller		See catalog GB 2427
EHA-PSU-201-A-10 Power supply		See catalog GB 2410A

Operating Data

KFD/TG4V-3

Valves without Amplifier

KFD/TG4V-3 VALVES WITHOUT INTEGRAL AMPLIFIER (requires a Eurocard amplifier, refer to Supporting Products)

Data is typical with fluid at 36 cSt (168 SUS) and 50° C (122° F).

Max current, at 50° C (122° F)	2,7 A
Coil resistance, at 20° C (68° F)	1,87 Ω
Step response	
Step size (% of max spool stroke)	Time to reach 90% of required step:
0 – 100%	18 ms
100% – 0	19 ms
+90 – -90% (KBFDG4V3-3 only)	30 ms
Type of protection, with electrical plugs fitted correctly	IEC60529, Class IP65
Electromagnetic compatibility (EMC)	
Emmision (10V/m)	EN 50081-2
Immunity (10V/m)	EN 50082-2
Maximum allowable ambient air temperature	60° C (140° F)
Maximum allowable oil temperature	60° C (140° F)
Supporting products:	
Eurocard amplifiers	EEA PAM 533 A/B/C/D/E/F See catalog GB-2464

KFD/TG4V-3 AND KBFD/4V-3 VALVES (ALL VALVES)

Relative duty factor	Continuous rating (ED = 100%)
Hysteresis with flow through P–A–B–T	<1% of max stroke (center-to-offset)
Mass:	
KFDG4V-3	2,7 kg (5.9 lb) approx.
KBFDG4V-3	3,1 kg (6.8 lb) approx.
KFTG4V-3	2,1 kg (4.6 lb) approx.
KBFTG4V-3	2,5 kg (5.5 lb) approx.
Portable test equipment	
EBA TEQ 460 A 10	See catalog V-ELAC-TM001-E

Pressure and Flow Rates

Maximum pressures, bar (psi)

MODEL	PORT L CONDITION	PORTS P, A, B	T	L
All models for normal usage (L port not connected)	Normally blocked by mounting surface	315 (4500)	160 (2300)	160 (2300)
		350 (5000)	105 (1500)	105 (1500)
For K(B)FDG4V-3**C**N/F-Z models only a higher "T" port pressure is allowed if the "L" port is connected directly to tank.	Drained directly to tank	350 (5000)	210 (3000)	10 (150)

Performance Curves

Power Capacity Envelopes

Single Solenoid Models: K(B)FTG4V-3

Spool types as noted

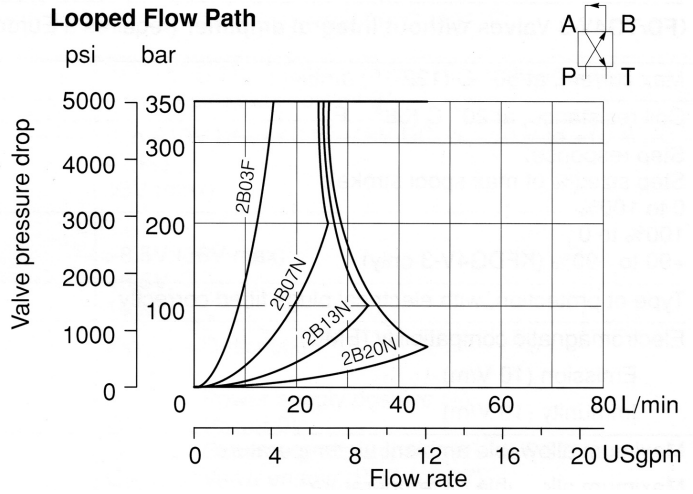

Single Flow Path

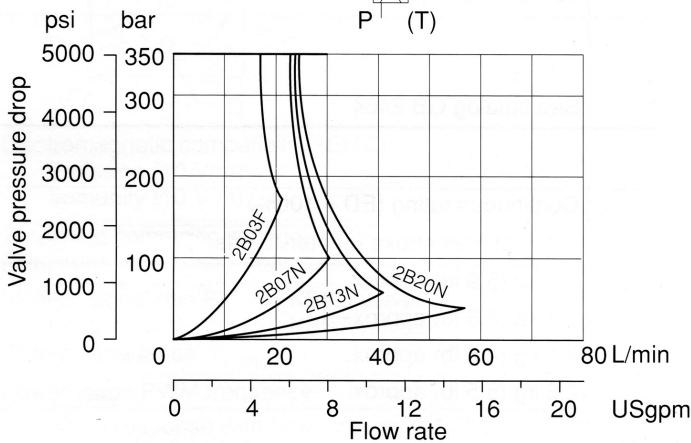
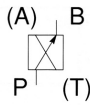

Parallel Flow Path

Use parallel flow path module
KDGMA-3-616265-10 (see page 12)

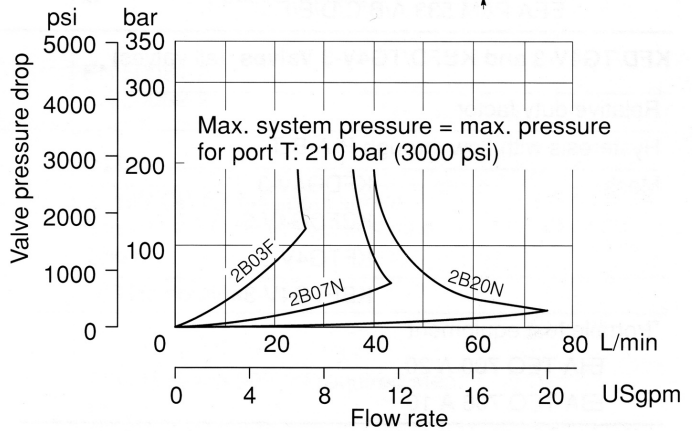
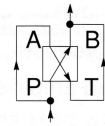

Double Solenoid Models: K(B)FDG4V-3

Spool types as noted

Single Flow Path

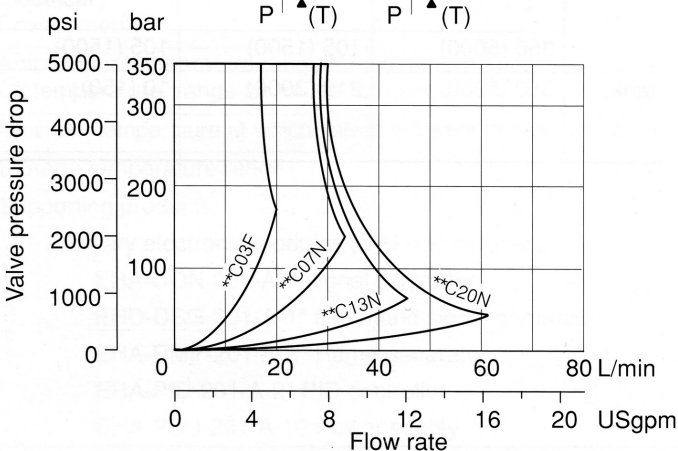
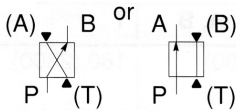

Looped Flow Path

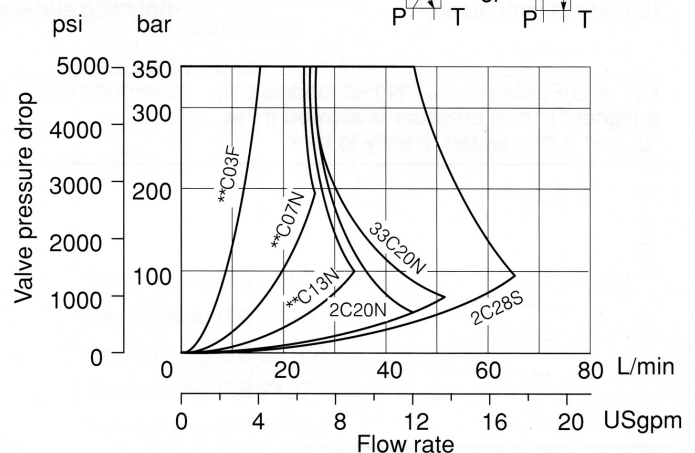
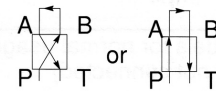

Performance Curves

Flow Gain Curves

When using the single solenoid throttle valves version (K*FT) a parallel flowpath module (page 12) can be used to approximately double the flow rate.

KBF valves are preset at the factory to compensate for

the effect of spool overlap. Curves shown include deadband compensation provided for the KF valve by the Vickers Eurocard Amplifier EEA-PAM-533-* -32 (user adjustable).

K(B)FD/TG4V-3

Spool types as noted

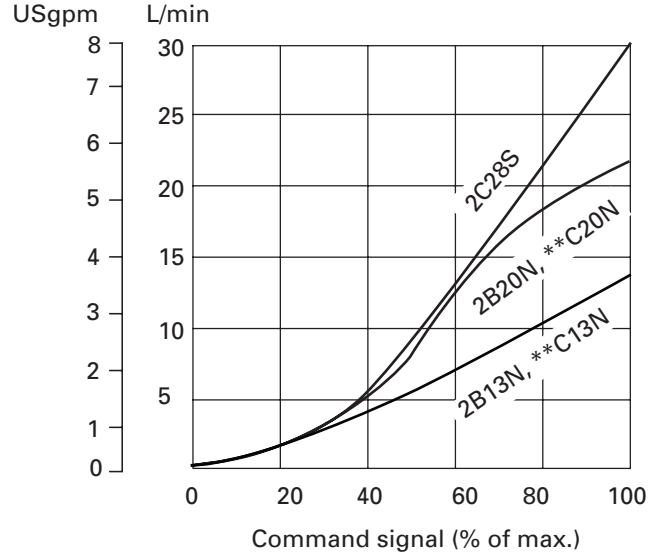
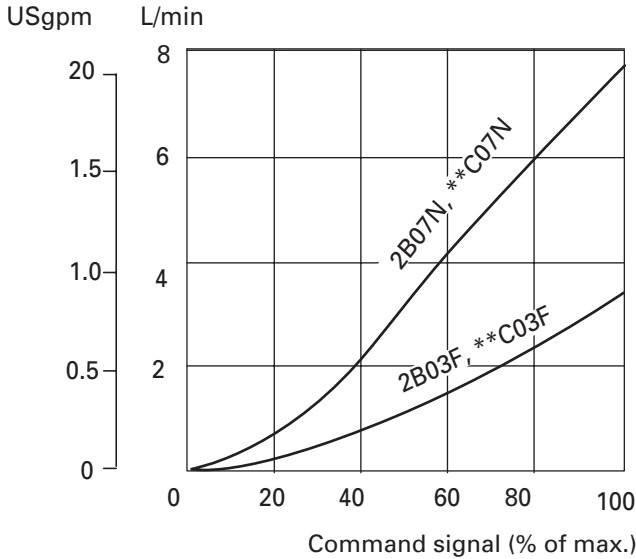

Single flowpath (e.g. P-A) pressure drop, $\Delta p = 5$ bar (72 psi) ■.

■ At other Δp values and within the power capacity envelopes, flow rates approximate to:

$$Q_x = Q_d \sqrt{\frac{\Delta p_x}{\Delta p_d}}$$

where Q_d = Datum flow rate
 Δp_d = Pressure drop at datum flow rate
 Δp_x = Required Δp

Frequency Response (Typical)

For an amplitude of $\pm 25\%$ max. flow about the 50% flow, at Δp (P-B) = 5 bar (72 psi)

KBFD/TG4V-3

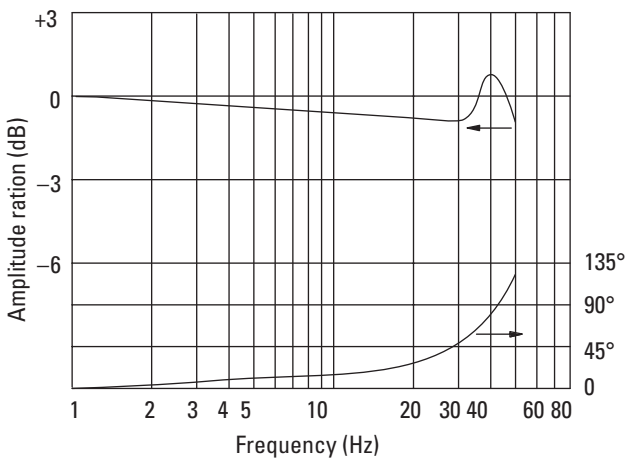

KFD/TG4V-3

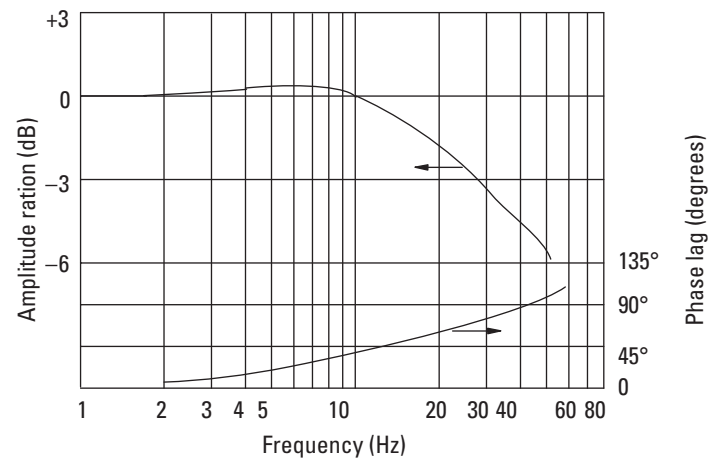

Installation Dimensions



KFDG4V-3

mm (inch)

Solenoid plug (ISO 4400/DIN 43650); gray, marked A, for V models, or black, marked B, for non-V models; see [15] in "Model Code"

Solenoid plug (ISO 4400/DIN 43650); black, marked B, for V models, or gray, marked A, for non-V models; see [15] in "Model Code"

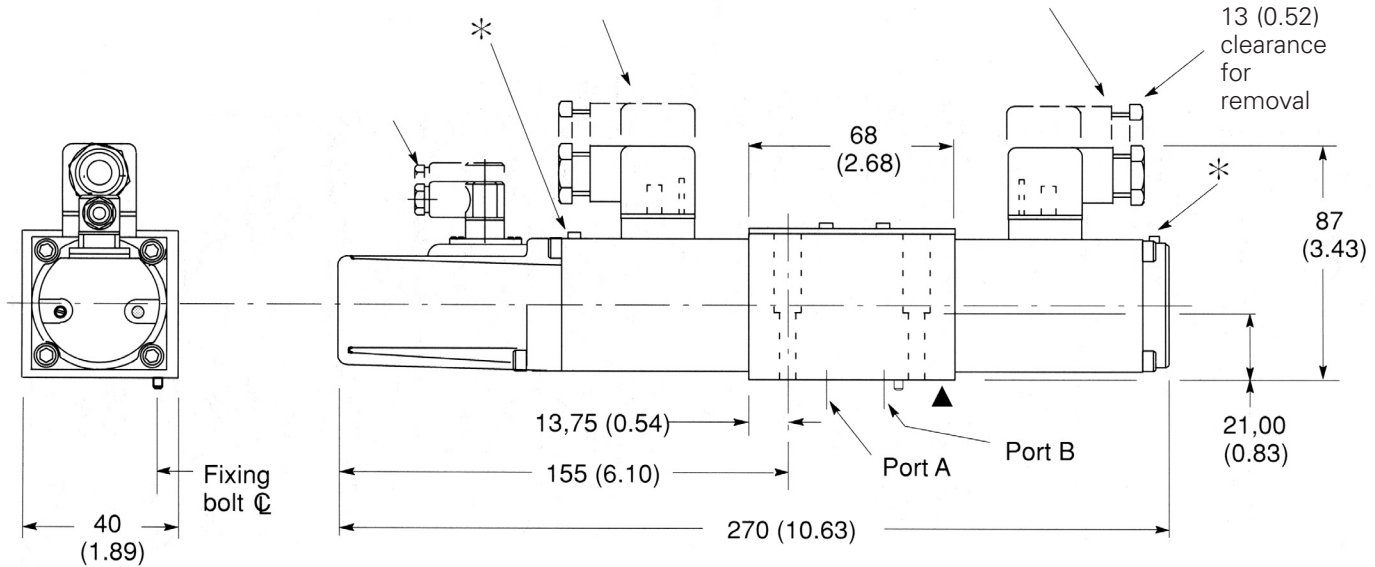

KFTG4V-3

mm (inch)

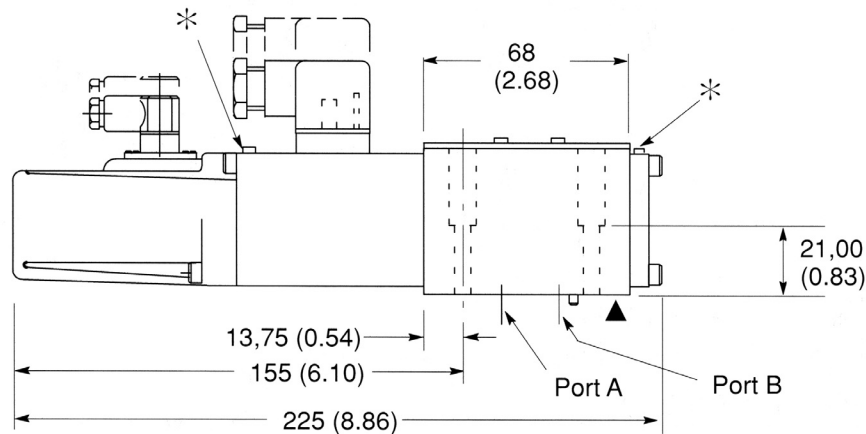

▲ Mounting surface seals supplied

NOTE: For optimum valve operation, bleed the air from the proportional solenoids at initial start-up. This may be done as follows:

- The valve may be pressurized by removing the bleed screws until no bubbles appear and then reinstalling bleed screws, or...

- Remove both bleed screws, and use a standard oil can nozzle to pump fluid in one side until it flows, free of air bubbles, out the other side. Reinstall screws.

If there is no inherent back pressure in the tank port of the circuit do not allow the tank line to empty. This may

be prevented by installing a check valve in the tank line. The cracking pressure of the check valve should be in the range of 22 - 45 psi (1.5 - 3 bar).

Installation Dimensions

KBFDG4V-3

mm (inch)

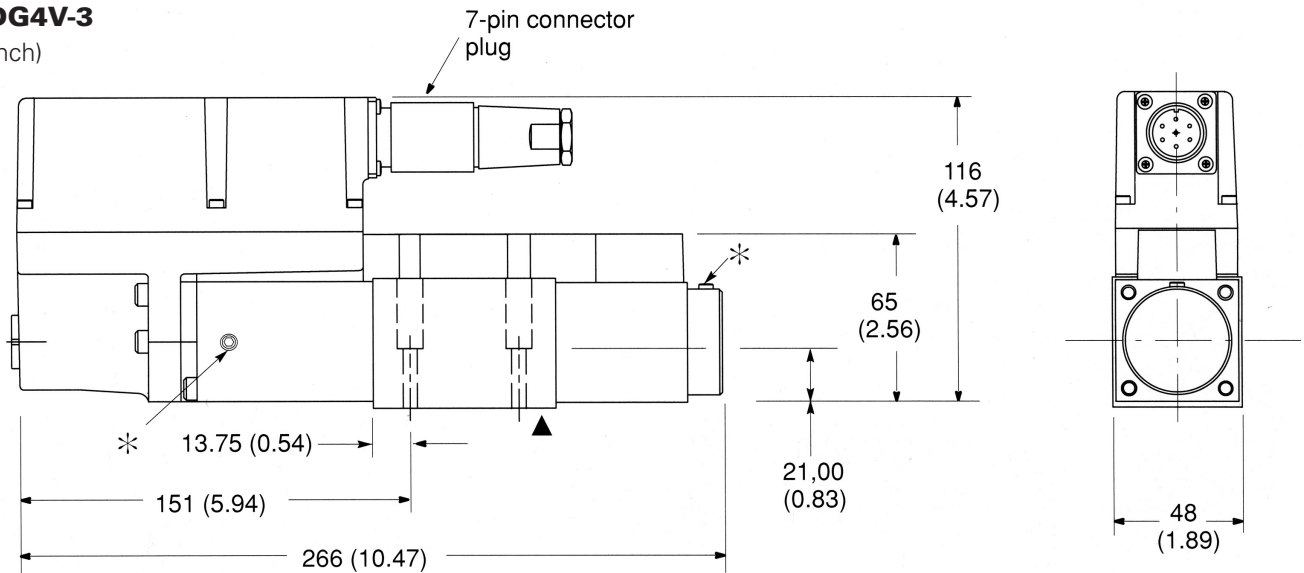

KBFTG4V-3

mm (inch)

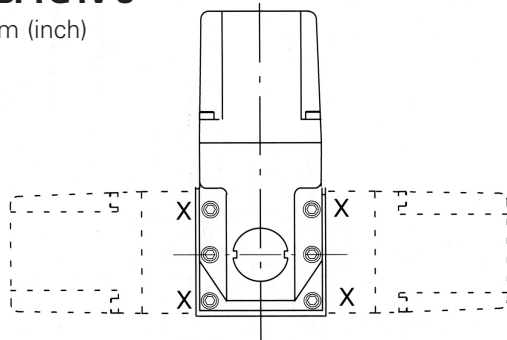

Amplifier and solenoid may be rotated 90° as shown by removing 4 screws shown X. Re-torque to 7-9 Nm (6-7 lbf ft)

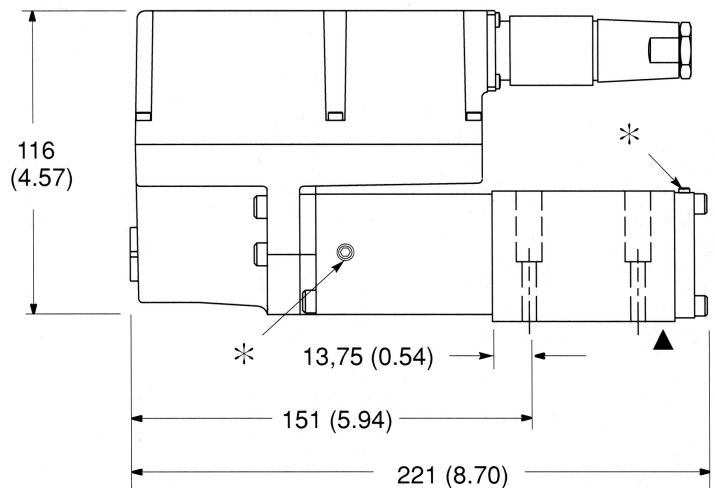

Warning

Valves with integral amplifiers are supplied with or without the metal 7-pin plug. The Vickers plug, part no. 934939, must be correctly fitted to ensure that the EMC rating and IP67 rating are achieved. The plug retaining nut must be tightened with a torque of 2,0-2,5 Nm (1.5-2.0 lbf ft) to effect a proper seal.

▲ Mounting surface seals supplied.

* Bleed screw locations Air bleed, Socket Head Cap Screw.

Torque to 2,5-3,0 Nm (2.0-2.5 lbf ft)

Parallel Path Flow Module

Size 03 Parallel-Flow-Path Module

KDGMA-3-616265-1*

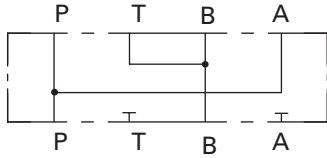

Typically used for doubling effective flow capability of single solenoid proportional valves (throttle valves), as illustrated in "Typical Applications".

▲ A, TA and TB ports at subplate face are blind holes fitted with O-seals.

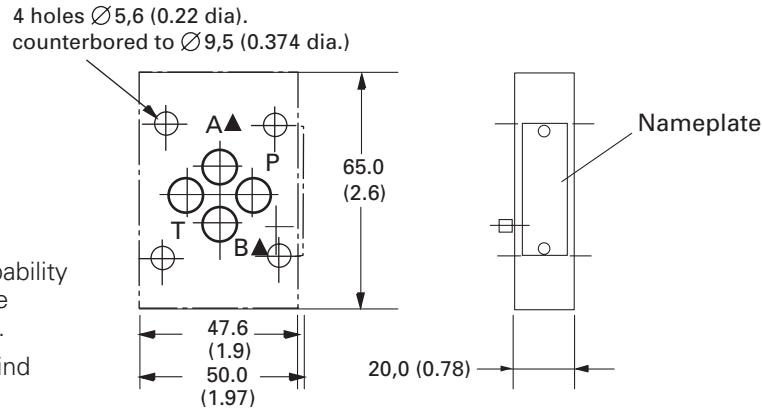

Subplates and Mounting Surfaces

General Description

If a subplate is not used, a machined pad must be provided for valve mounting. Pad must be flat within 0,0127 mm (.0005 inch) and smooth within 1,6 µm (63 microinch). Mounting bolts, when provided by customer, should be ISO 898 class 12.9 or better.

Dimensional Tolerances

Dimensional tolerance on interface drawings is ± 0.2 mm (± 0.008 ") except where otherwise stated. ISO 4401 specifies inch conversion to ± 0.01 " .

Conversion for Metric

ISO 4401 gives dimensions in mm. Inch conversions are accurate to 0.01" unless otherwise stated.

Mounting Bolt Tapping

ISO 4401 gives metric thread tapings. Alternate UNC tapping are Vickers recommendations that allow these plates and associated valves to be used up to their maximum pressures, when using Vickers recommended bolt kits, or bolts of an equivalent

strength. It is recommended that customer's own manifold blocks for UNC bolts should be tapped to the minimum depths given in the footnotes.

SUBPLATES

Description and Mass kg (lb)	Functional Symbol	Model Code	Max. Pressure
Single-station subplate; rear ports P, T, A, B; side port L Cast iron 1,3 (2.9)		KDGV3-3-1*-R ▲ KDGV3-3-676803-1* (SAE/UNF ports)	250 bar (3600 psi)

* Design number subject to change. No change of installation dimensions for design numbers 10 to 19 or 21 to 29 inclusive.

▲ "S" suffix = SAE/UNC ports and /or UNC fixing bolt tapings and/or orifice plugs as appropriate.

"R" suffix = BSPF and/or metric fixing bolt tapping and/or orifice plugs as appropriate.

Installation Dimensions

Single-Station Subplates

All dimensions in mm (inches)

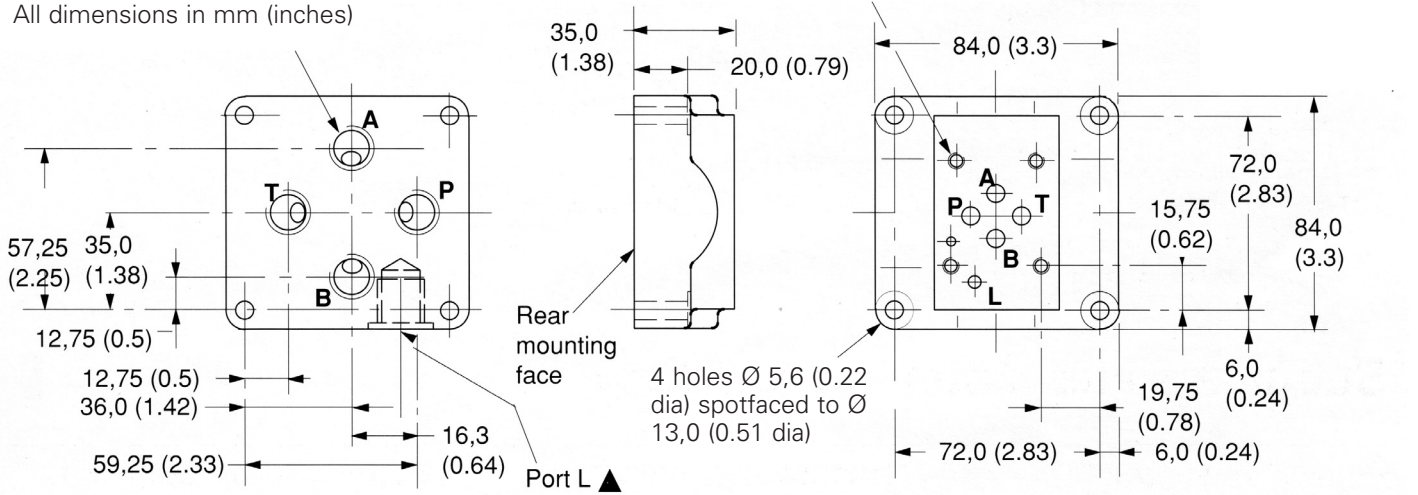

Port Threads

PORTS P, T, A, B

Model		Ports P, T, A, B	Port L
BSPF ports / M5 mounting bolts: KDGVM-3-1*-R	Rear	G 3/8" (3/8" BSPF) x 12,0 (0.47) deep	G 1/8" (1/8" BSPF) x 12,0 (0.47) deep
SAE ports/#10-24 UNC mounting bolts: KDGVM-3-676803-1*	Rear	3/4"-16 UNF-2B x 14,3 (0.56) deep (SAE)	7/16"-20 UNF-2B x 11,6 (0.46) deep (SAE)

Mounting Surface to ISO 4401 (Size 03)

This interface conforms to:
 ISO 4401-03-02-0-05

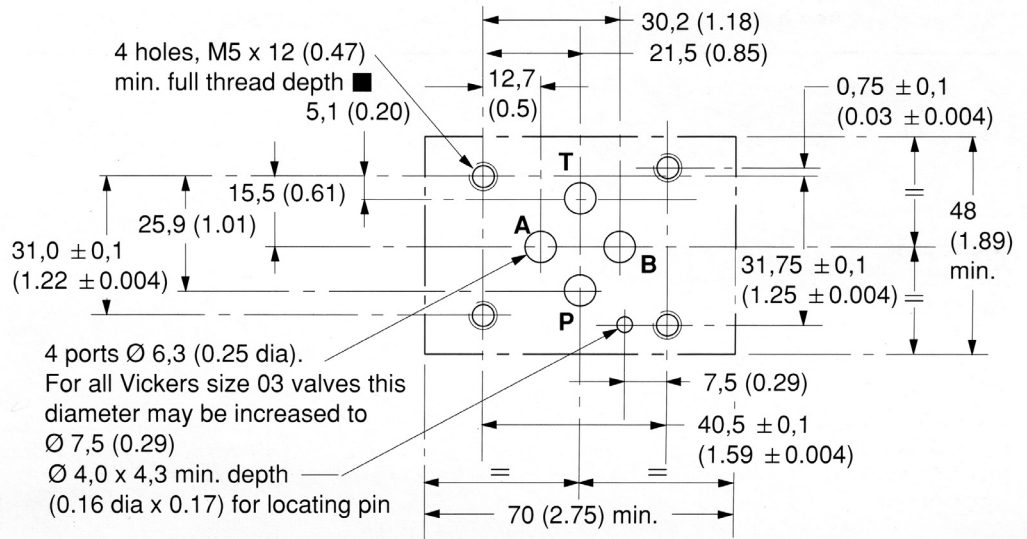

■ #10-24 UNC-2B optional

Interface with Additional Drain Port

ANSI/B93.7M (and NFPA) size 03 CETOP R35H4.2-4-03, plus location pin hole.

Typically used for proportional and other valves requiring an additional drain port.

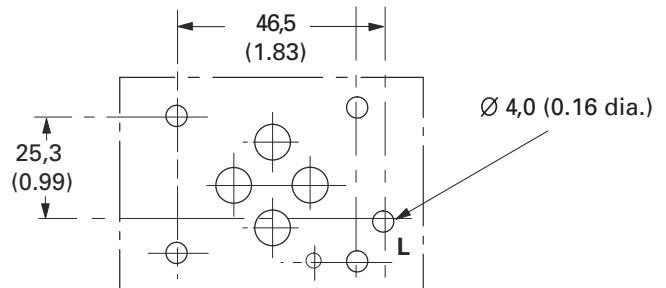

Electrical Information

Block Diagram Voltage Input (M1) KBFDG 4V-3

KBFDG4V-3 Wiring

Connections must be made via the 7-pin plug mounted on the amplifier. See page 15 of this leaflet and Eaton's Installation Wiring Practices for Vickers™ Electronic Products, leaflet 2468.

Recommended cable sizes are:

Power cables:

For 24V supply 0,75 mm² (18 AWG) up to 20m (65 ft)
1,00 mm² (16 AWG) up to 40m (130 ft)

Signal cables:

0,50 mm² (20 AWG)

Screen (shield):

A suitable cable would have 7 cores, a separate screen for the signal wires and an overall screen.

Cable outside diameter 8,0–10,5 mm (0.31–0.41 inches)

See connection diagram on next page.

KFDG4V-3 Wiring

Wiring details for these valves are contained in the appropriate Eurocard literature and Eaton's Installation Wiring Practices for Vickers™ Electronic Products leaflet 2468.

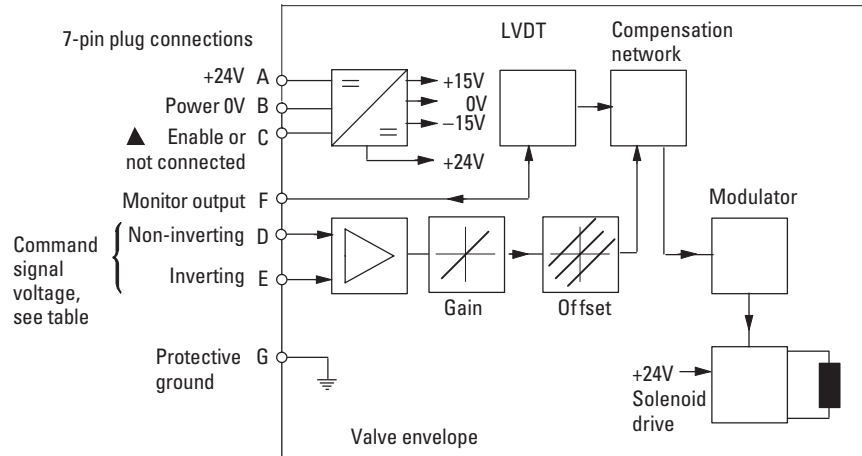

▲ Pin C is used for a valve enable signal with electrical connections PH7 and PR7.

COMMAND SIGNALS AND OUTPUTS, M1

7-pin plug Flow direction

Pin D	Pin E	
Positive	0V	
0V	Negative	P to A
$U_d - U_e = \text{Positive}$		
Negative	0V	
0V	Positive	P to B
$U_d - U_e = \text{Negative}$		



WARNING

All power must be switched off before connecting/disconnecting any plugs.

Electrical Information

Block Diagram Current Input (M2) KFSDG4V-3

KBSDG4V-3 Wiring

Connections must be made via the 7-pin plug mounted on the amplifier. See page 15 of this leaflet and Eaton's Installation Wiring Practices for Vickers™ Electronic Products, leaflet 2468.

Recommended cable sizes are:

Power cables:

For 24V supply

0,75 mm² (18 AWG) up to 20m (65 ft)
1,00 mm² (16 AWG) up to 40m (130 ft)

Signal cables:

0,50 mm² (20 AWG)

Screen (shield):

A suitable cable would have 7 cores, a separate screen for the signal wires and an overall screen.

Cable outside diameter 8,0–10,5 mm (0.31–0.41 inches)

See connection diagram on next page.

KFDG4V-3 Wiring

Wiring details for these valves are contained in the appropriate Eurocard literature and Eaton's Installation Wiring Practices for Vickers™ Electronic Products leaflet 2468.

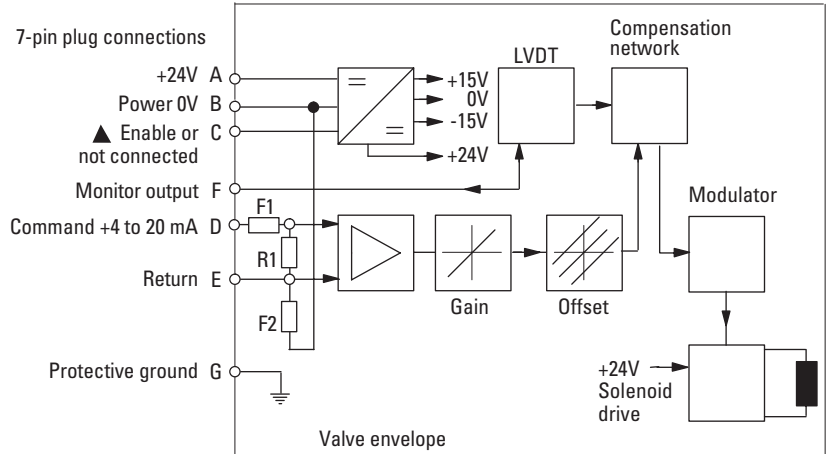

▲ Pin C is used for a valve enable signal with electrical connections PH7 and PR7.

R1 shunt resistor 100R

F1, F2 resettable fuse

COMMAND SIGNALS AND OUTPUTS, M2

7-pin plug			
Pin D	Pin E	Pin B	Flow direction
More than 12 mA	Current return	Power ground	P to A
Less than 12 mA	Current return	Power ground	P to B



WARNING

All power must be switched off before connecting/disconnecting any plugs.

Electrical Information

Wiring Connections Voltage Input (M1)

■ Spool position monitor voltage (pin F) will be referenced to the KB valve local ground.



WARNING

Do not ground pin C.

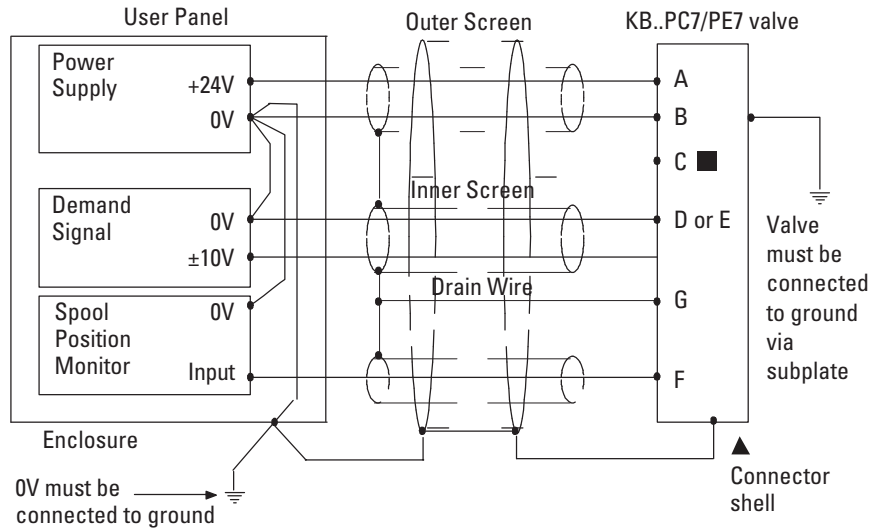

Wiring Connections for M1 Valves with Enable Feature

■ Note: In applications where the valve must conform to European RFI/EMC regulations, the outer screen (shield) must be connected to the outer shell of the 7 pin connector, and the valve body must be fastened to the earth ground. Proper earth grounding practices must be observed in this case, as any differences in command source and valve ground potentials will result in a screen (shield) ground loop.

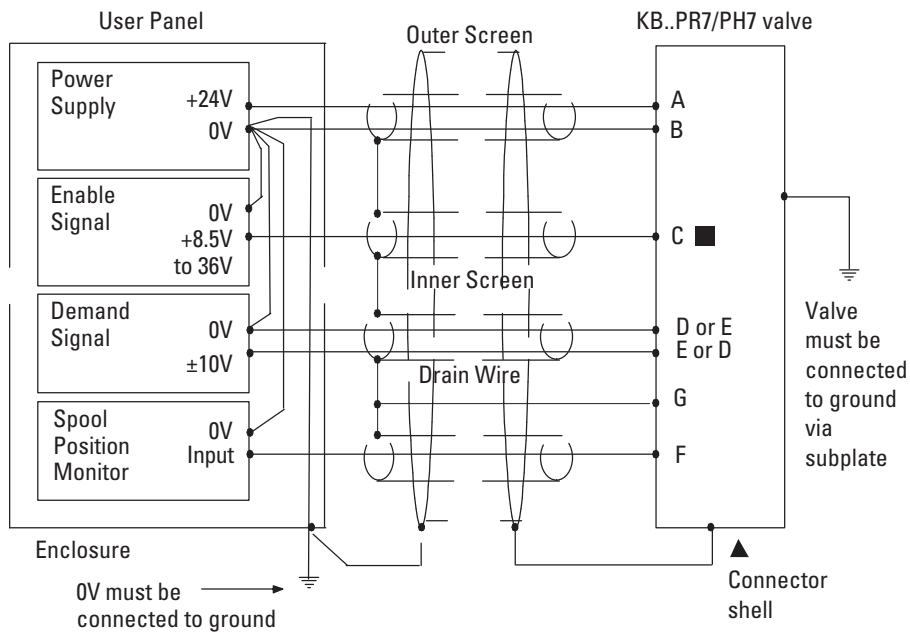

Electrical Information

Wiring Connections Current Input (M2)

■ Spool position monitor voltage (pin F) will be referenced to the KB valve local ground.



WARNING

Do not ground pin C.

Wiring Connections for M2 Valves with Enable Feature

▲ Note: In applications where the valve must conform to European RFI/EMC regulations, the outer screen (shield) must be connected to the outer shell of the 7 pin connector, and the valve body must be fastened to the earth ground. Proper earth grounding practices must be observed in this case, as any differences in command source and valve ground potentials will result in a screen (shield) ground loop.

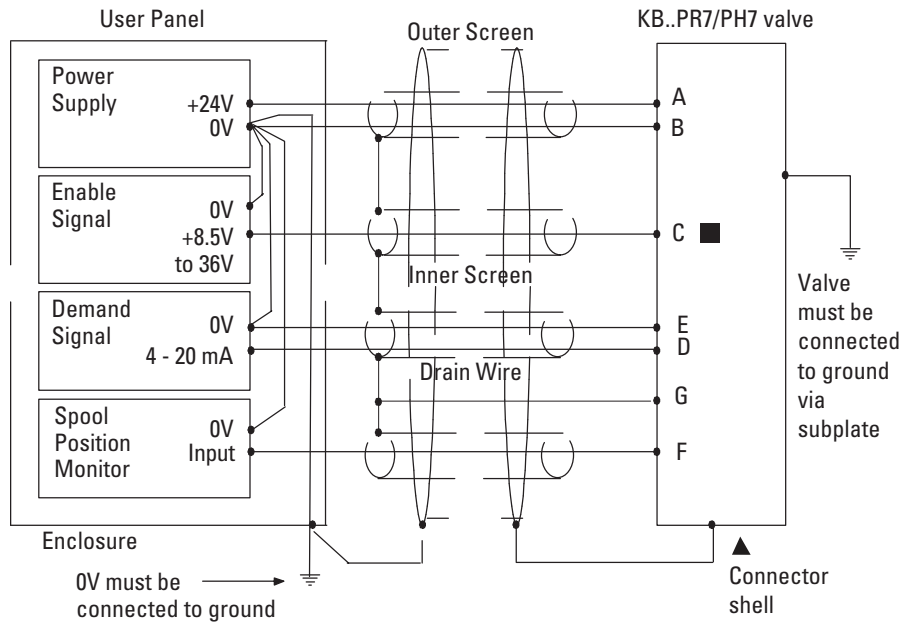
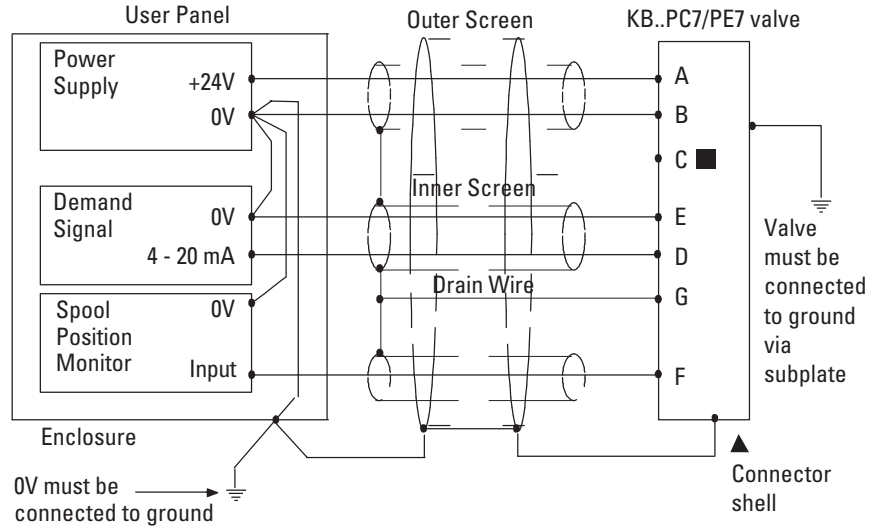

WARNING

Electromagnetic Compatibility (EMC)

It is necessary to ensure that the valve is wired up as above. For effective protection the user electrical cabinet, the valve subplate or manifold and the cable screens should be connected to efficient ground points.

The metal 7 pin connector part no. 934939 should be used for the integral amplifier. In all cases both valve and

cable should be kept as far away as possible from any sources of electromagnetic radiation such as cables carrying heavy current, relays and certain

kinds of portable radio transmitters, etc. Difficult environments could mean that extra screening may be necessary to avoid the interference.

It is important to connect the 0V lines as shown above. The multi-core cable should have at least two screens to separate the

demand signal and monitor output from the power lines.

The enable line to pin C should be outside the screen which contains the demand signal cables.

Application Data

Fluid Cleanliness

Proper fluid condition is essential for long and satisfactory life of hydraulic components and systems. Hydraulic fluid must have the correct balance of cleanliness, materials and additives for protection against wear of components, elevated viscosity and inclusion of air.

Recommendations on contamination control methods and the selection of products to control fluid condition are included in Vickers publication 9132 or 561, "Vickers Guide to Systemic Contamination Control". The book also includes information on the Vickers concept of "ProActive Maintenance".

The following recommendations are based on ISO cleanliness levels at 2 µm, 5 µm and 15 µm:

For products in this catalog the recommended levels are:

0 to 70 bar (1000 psi) 18/16/13

70 + bar (1000 + psi) 17/15/12

Vickers products, as any components, will operate with apparent satisfaction in fluids with higher cleanliness codes than those described. Other manufacturers will often recommend levels above those specified.

Experience has shown, however, that life of any hydraulic components is shortened in fluids with higher cleanliness codes than those listed above. These codes have been proven to provide a long trouble-free service life for the products shown, regardless of the manufacturer.

Hydraulic Fluids

Materials and seals used in these valves are compatible with antiwear hydraulic oils, and non-alkyl-based phosphate esters. The extreme operating viscosity range is 500 to 13 cSt (2270 to 70 SUS) but the recommended running range is 54 to 13 cSt (245 to 70 SUS).

Installation

The proportional valves in this catalog can be mounted in any attitude, but it may be necessary in certain demanding applications, to ensure that the solenoids are kept full of hydraulic fluid. Good installation practice dictates that the tank port and any drain port are piped so as to keep the valves full of fluid once the system start-up has been completed.

Mounting Bolt Kits

For K(B)FD/TG4V-3

BK02-156493M (metric)

BK590716(inch)

If not using Vickers recommended bolt kits, bolts used should be to ISO 898, 12.9 or better.

Seal Kits

KFD/TG4V-3 565108

KBFD/TG4V-3-1* 02-332693

Plugs

KBFDG4V

7-pin plug (metal) 934939

7-pin plug (plastic) 694534

(metal plug must be used for full EMC protection)

NOTE: An alternative metal connector which gives EMC protection but not IP67 rating is available from ITT-Cannon, part number CA06-COM-E-14S-A7-S.

KFDG4V

Solenoid (black) 710775

Solenoid (gray) 710776

LVDT (gray) 458939

Extension Cable

Extension Cable: Adapter for extending 7 core cable when changing from KA to KB valve and existing wiring is not long enough. Consists of a 7 pin plug, a 7 pin socket and a length of cable, fully assembled for ease of use.

Extension Cable 944450

Service Information

The products from this range are preset at the factory for optimum performance; disassembling critical items would destroy these settings. It is therefore recommended that should any mechanical or electronic repair be necessary they should be returned to the nearest Vickers repair center. The products will be refurbished as necessary and retested to specification before return.

Field repair is restricted to the replacement of the seals.

NOTE: The feedback/solenoid assembly installed in this valve should not be disassembled.

Eaton
Hydraulics Business USA
14615 Lone Oak Road
Eden Prairie, MN 55344
USA
Tel: 952-937-9800
Fax: 952-294-7722
www.eaton.com/hydraulics

Eaton
Hydraulics Business Europe
Route de la Longeraie 7
1110 Morges
Switzerland
Tel: +41 (0) 21 811 4600
Fax: +41 (0) 21 811 4601

Eaton
Hydraulics Business Asia Pacific
11th Floor Hong Kong New World Tower
300 Huaihai Zhong Road
Shanghai 200021
China
Tel: 86-21-6387-9988
Fax: 86-21-6335-3912