

Series CFB solenoid valves

2/2-way and 3/2-way
Normally Closed (NC) and Normally Open (NO)



- » Solenoid valves for air and water
- » Great reliability over time, even in heavy working conditions

The valve function is determined by a poppet or by a diaphragm with operation direct or indirect. Different versions are available according to the nominal diameter and to the threaded ports, as shown in the following tables. They can thus satisfy various requirements in terms of flow rates and working pressures.

Series CFB solenoid valves for general purpose are available in the NC and NO version, 2/2 and 3/2-way.

Special versions are available on demand for the protection against the water hammer or with specific treatments for the interception of aggressive fluids.

GENERAL DATA

TECHNICAL FEATURES

Function	2/2 NC - 3/2 NC - 2/2 NO
Operation	direct acting poppet type - servo-assisted with diaphragm
Pneumatic connections	G1/8 ... G2 threads
Nominal diameter	1.4 ... 50 mm
Nominal flow	See Kv
Kv (l/min)	0.14 ... 36.0
Operating pressure	0 ÷ 0.8 ... 22 bar
Operating temperature	-10°C + +90°C ... 140°C
Media	air, water, liquid and gaseous fluids with max viscosity 37 cSt (5° E)
Response time	ON <15 msec - OFF <25 msec
Installation	in any position

MATERIALS IN CONTACT WITH THE MEDIUM

Body	brass (alimentary or anti-limestone nickel-platings on demand)
Seals	NBR (CFB-A) - FKM (CFB-B, CFB-D) - EPDM (on demand)
Internal parts	stainless steel - stainless steel and brass (CFB-D1)

ELECTRICAL FEATURES

Voltage	12 V DC, 24 V DC - 24 V 50 Hz, 110 V 50/60 Hz, 220/230 V 50/60 Hz
Voltage tolerance	±5% (DC) - ±10% (AC)
Power consumption	10 ... 30 W (DC) - 9 ... 29 VA (AC)
Duty cycle	ED 100%
Electrical connection	H (180°C)
Protection class	DIN 43650 connector, (A shape) IP65 with connector

Special versions available on demand

It is recommended to use connections with internal diameters bigger than valve orifices, otherwise there may be a performance change.

CODING EXAMPLE

CFB - **A** **1** **3** **L** - **R** **1** - **B7** **E**

CFB	SERIES
A	OPERATION: A = indirect B = direct with linked diaphragm D = direct
1	NUMBER OF WAYS - POSITIONS: 1 = 2/2-way NO 2 = 2/2-way NC 3 = 3/2-way NC
3	CONNECTIONS: 1 = G1/8 2 = G1/4 3 = G3/8 4 = G1/2 5 = G3/4 6 = G1 7 = G1 1/4 8 = G1 1/2 9 = G2
L	NOMINAL DIAMETER: A = 1,4 mm B = 2 mm C = 2,5 mm D = 2,8 mm F = 4 mm G = 6 mm J = 8 mm L = 11,5 mm M = 13 mm N = 13,5 mm P = 18 mm R = 26 mm T = 32 mm X = 45 mm Z = 50 mm
R	DIAPHRAGM MATERIAL: R = NBR W = FKM E = EPDM (on demand)
1	BODY MATERIAL: 1 = brass 2 = alimentary anti-limestone nickel-plated brass for high temperatures (on demand) 3 = alimentary nickel-plated brass (on demand)
B7	SOLENOID DIMENSION: B7 = 22 mm B8 = 30 mm B9 = 36 mm
E	SOLENOID VOLTAGE: B = 24V AC 50 Hz D = 110V AC 50/60 Hz E = 230V AC 50/60 Hz 2 = 12V DC 3 = 24V DC
NOTE: for some directly operated 2/2 NO solenoid valves, the solenoid to be used is the B8*K type (see also the TABLE FOR THE COUPLING BETWEEN SOLENOIDS AND VALVES on page 2/1.30.03).	

TABLE FOR THE COUPLING BETWEEN SOLENOIDS AND VALVES

New

See solenoids and connectors for solenoids on page 2/2.35.03 - 2/2.35.05

Mod. B8/B9 = mod. 124-800

Mod. B7 = mod. 122-800

Mod.	24V AC 50 Hz	110V AC 50/60 Hz	220/230V AC 50/60 Hz	12V DC	24V DC
Directly operated solenoid valve, 2/2 and 3/2 NC, 2/2 NO					
CFB-D21C-W1-	B8B (15VA)	B8D (15VA)	B8E (15VA)	B82 (19W)	B83 (19W)
CFB-D21F-W1-	B8B (15VA)	B8D (15VA)	B8E (15VA)	B82 (19W)	B83 (19W)
CFB-D22C-W1-	B8B (15VA)	B8D (15VA)	B8E (15VA)	B82 (19W)	B83 (19W)
CFB-D22F-W1-	B8B (15VA)	B8D (15VA)	B8E (15VA)	B82 (19W)	B83 (19W)
CFB-D22G-W1-	B8B (15VA)	B8D (15VA)	B8E (15VA)	B82 (19W)	B83 (19W)
CFB-D23J-W1-	B9B (29VA)	B9D (29VA)	B9E (29VA) **	not available	B93 (30W)
CFB-D24J-W1-	B9B (29VA)	B9D (29VA)	B9E (29VA) **	not available	B93 (30W)
CFB-D24M-W1-	B9B (29VA)	B9D (29VA)	B9E (29VA) **	not available	not available
CFB-D31A-W1-	B8B (15VA)	B8D (15VA)	B8E (15VA)	B82 (19W)	B83 (19W)
CFB-D31D-W1-	B8B (15VA)	B8D (15VA)	B8E (15VA)	B82 (19W)	B83 (19W)
CFB-D32A-W1-	B8B (15VA)	B8D (15VA)	B8E (15VA)	B82 (19W)	B83 (19W)
CFB-D32D-W1-	B8B (15VA)	B8D (15VA)	B8E (15VA)	B82 (19W)	B83 (19W)
CFB-D11A-W1-	B8BK (15VA)	B8DK (15VA) **	B8EK (15VA) **	B82K (19W)	B83K (19W)
CFB-D12D-W1-	B8BK (15VA)	B8DK (15VA) **	B8EK (15VA) **	B82K (19W)	B83K (19W)
CFB-D13J-W1-	B9B (29VA)	B9D (29VA) **	B9E (29VA) **	not available	not available
Directly operated solenoid valve with constrained diaphragm, 2/2 NC					
CFB-B23L-W1-	B9B (29VA)	B9D (29VA)	B9E (29VA)	not available	B93 (30W)
CFB-B24N-W1-	B9B (29VA)	B9D (29VA)	B9E (29VA)	not available	B93 (30W)
CFB-B25P-W1-	B9B (29VA)	B9D (29VA)	B9E (29VA)	not available	B93 (30W)
CFB-B26R-W1-	B9B (29VA)	B9D (29VA)	B9E (29VA)	not available	B93 (30W)
Indirectly operated solenoid valve, 2/2 NC					
CFB-A23L-R1-	B7B (9VA) *	B7D (9VA)	B7E (9VA)	B72 (10W)	B73 (10W)
CFB-A24N-R1-	B7B (9VA) *	B7D (9VA)	B7E (9VA)	B72 (10W)	B73 (10W)
CFB-A25P-R1-	B7B (9VA) *	B7D (9VA)	B7E (9VA)	B72 (10W)	B73 (10W)
CFB-A26R-R1-	B7B (9VA) *	B7D (9VA)	B7E (9VA)	B72 (10W)	B73 (10W)
CFB-A27T-R1-	B8B (15VA)	B8D (15VA)	B8E (15VA)	B82 (19W)	B83 (19W)
CFB-A28X-R1-	B8B (15VA)	B8D (15VA)	B8E (15VA)	B82 (19W)	B83 (19W)
CFB-A29Z-R1-	B8B (15VA)	B8D (15VA)	B8E (15VA)	B82 (19W)	B83 (19W)
Indirectly operated solenoid valve, 2/2 NO					
CFB-A13L-R1-	B7B (9VA) *	B7D (9VA)	B7E (9VA)	B72 (10W)	B73 (10W)
CFB-A14N-R1-	B7B (9VA) *	B7D (9VA)	B7E (9VA)	B72 (10W)	B73 (10W)
CFB-A15P-R1-	B7B (9VA) *	B7D (9VA)	B7E (9VA)	B72 (10W)	B73 (10W)
CFB-A16R-R1-	B7B (9VA) *	B7D (9VA)	B7E (9VA)	B72 (10W)	B73 (10W)
CFB-A17T-R1-	B8B (15VA)	B8D (15VA)	B8E (15VA)	B82 (19W)	B83 (19W)
CFB-A18X-R1-	B9B (29VA)	B9D (29VA)	B9E (29VA)	not available	B93 (30W)
CFB-A19Z-R1-	B9B (29VA)	B9D (29VA)	B9E (29VA)	not available	B93 (30W)
	* B7B solenoid with nominal bifrequency of 50/60 Hz		** only to be used with nominal frequency of 50 Hz		

Directly operated 2/2 NC - NO and 3/2 NC solenoid valve

New



The direct control of these solenoid valves enables them to work with operating pressures which are equal to zero. Ports: G1/8 and G1/2.

DRAWING LEGEND:

X = NC valve
Y = NO valve

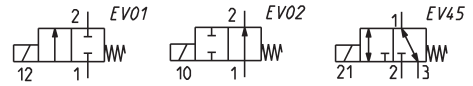
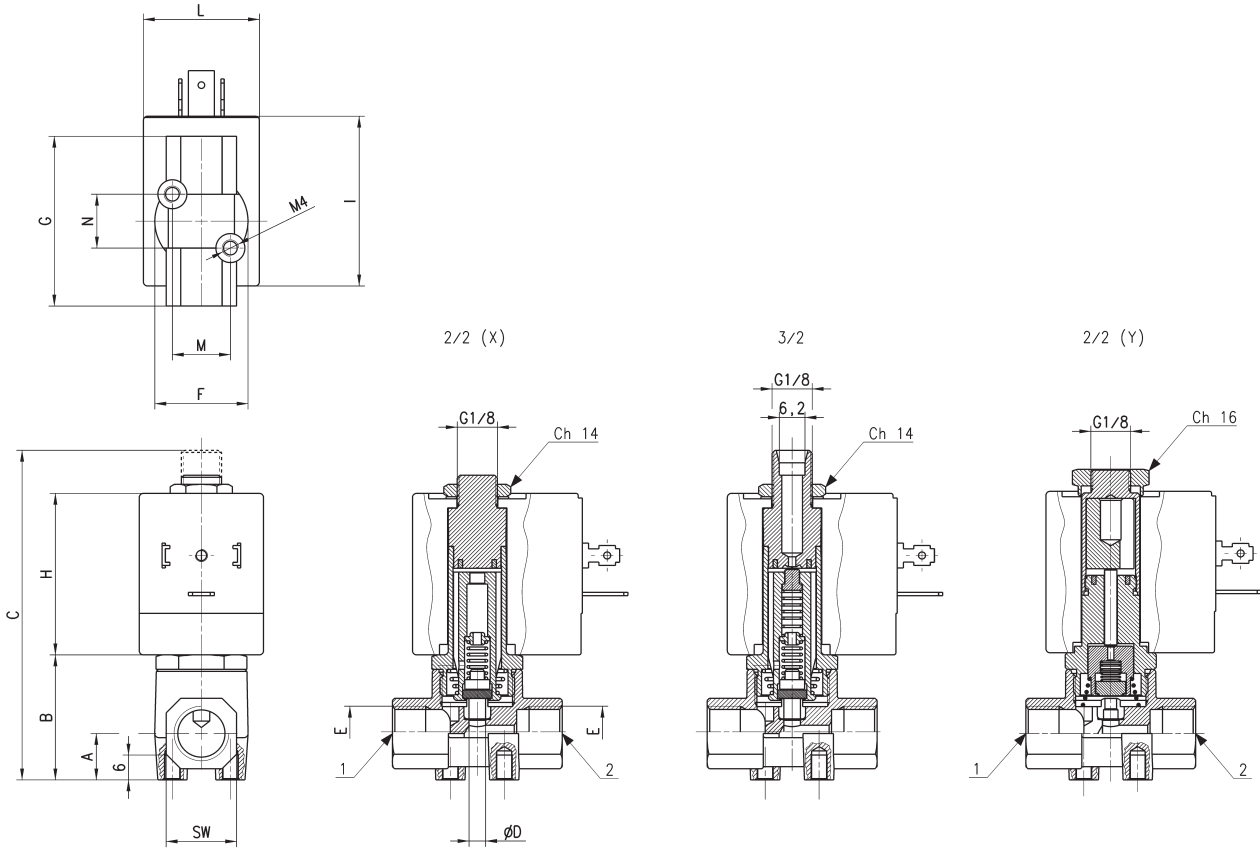

TABLE NOTES:

* = choose the suitable solenoid (see the table on page 2/1.30.03).
** = the performances shown in the table refer to the use with inlet from "2" and outlet from "1".
*** = 0 + 4 on demand



Mod.	Function	Orifice ØD (mm)	Kv [m³/h with water]	Pressure min-max (bar)	A	B	C	E	F	G	SW	H	I	L	N	M	Symbol
CFB-D21C-W1-*	2/2 NC	2.5	0.14	0 + 15 [AC / DC]	11	30	73.8	G1/8	23	41	17	39	41	30	13	14	EV01
CFB-D21F-W1-*	2/2 NC	4	0.25	0 + 6 [AC / DC]	11	30	73.8	G1/8	23	41	17	39	41	30	13	14	EV01
CFB-D22C-W1-*	2/2 NC	2.5	0.14	0 + 15 [AC / DC]	11	30	73.8	G1/4	23	41	17	39	41	30	13	14	EV01
CFB-D22F-W1-*	2/2 NC	4	0.25	0 + 6 [AC / DC]	12	31.5	75	G1/4	26	41	17	39	41	30	13	14	EV01
CFB-D22G-W1-*	2/2 NC	6	0.6	0 + 2.5 [AC / DC] ***	12	31.5	75	G1/4	26	41	17	39	41	30	13	14	EV01
CFB-D23J-R1-*	2/2 NC	8	1	0 + 2 [AC] - 0 + 0.8 [DC]	15	45	89	G3/8	37	55	27	39	47	36	22	22	EV01
CFB-D24J-R1-*	2/2 NC	8	1	0 + 2 [AC] - 0 + 0.8 [DC]	15	45	89	G1/2	37	55	27	39	47	36	22	22	EV01
CFB-D24M-R1-*	2/2 NC	13	2.4	0 + 1 [AC] - /	15	45	89	G1/2	37	55	27	39	47	36	22	22	EV01
CFB-D31A-W1-*	3/2 NC **	1.4	0.06	0 + 14 [AC / DC]	11	30	79.6	G1/8	23	41	17	39	41	30	13	14	EV45
CFB-D31D-W1-*	3/2 NC **	2.8	0.14	0 + 5 [AC / DC]	11	30	79.6	G1/8	23	41	17	39	41	30	13	14	EV45
CFB-D32A-W1-*	3/2 NC **	1.4	0.06	0 + 14 [AC / DC]	11	30	79.6	G1/4	23	41	17	39	41	30	13	14	EV45
CFB-D32D-W1-*	3/2 NC **	2.8	0.14	0 + 5 [AC / DC]	11	30	79.6	G1/4	23	41	17	39	41	30	13	14	EV45
CFB-D11A-W1-*	2/2 NO	1.4	0.07	0 + 22 [AC 50Hz / DC]	11	30	75	G1/8	23	41	17	39	41	30	13	14	EV02
CFB-D12D-W1-*	2/2 NO	2.8	0.20	0 + 7.5 [AC 50Hz / DC]	11	30	75	G1/4	23	41	17	39	41	30	13	14	EV02
CFB-D13J-W1-*	2/2 NO	8	1	0 + 1.5 [AC 50Hz]	15	45	89	G3/8	37	55	27	39	47	36	22	22	EV02

New
Directly oper. 2/2 NC solenoid valve with linked diaphragm

The diaphragm which is linked to the mobile plunger is a good arrangement between high fluid flow rates and working pressures (zero pressures as well).
Ports: from G3/8 to G1.
The standard diaphragm is supplied in FKM.

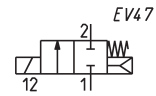
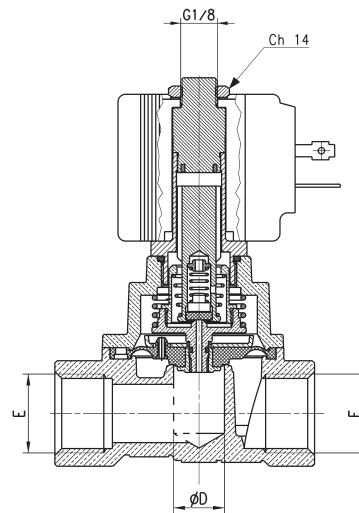
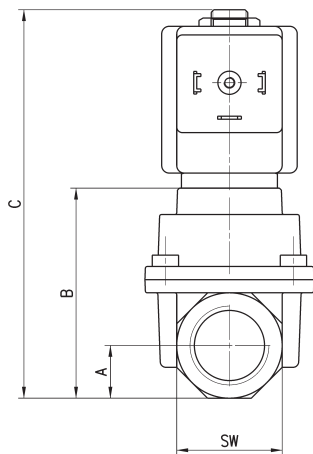
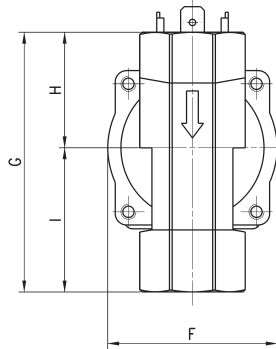

TABLE NOTE:

* = choose the suitable solenoid (see the table on page 2/1.30.03).



Mod.	Function	Orifice ØD (mm)	Kv [m³/h with water]	Pressure min-max (bar)	A	B	C	E	F	G	H	I	SW
CFB-B23L-W1-*	2/2 NC	11.5	2.1	0 + 15 [AC] - 0 + 8 [DC]	14	55.8	103.2	G3/8	45	64	28.2	35.8	28
CFB-B24N-W1-*	2/2 NC	13.5	2.5	0 + 15 [AC] - 0 + 8 [DC]	14	55.8	103.2	G1/2	45	69	30.7	38.3	28
CFB-B25P-W1-*	2/2 NC	18	5	0 + 15 [AC] - 0 + 5 [DC]	21	72	119.4	G3/4	71	93	43.5	49.5	42
CFB-B26R-W1-*	2/2 NC	26	8	0 + 15 [AC] - 0 + 5 [DC]	21	72	119.4	G1	71	93	43.5	49.5	42

New

Indirectly operated 2/2 NC solenoid valve



The pilot of these indirectly operated solenoid valves controls the diaphragm position through a differential pressure. These valves are therefore particularly suitable for controlling high fluid flow rates and require very low working pressures. Ports: from G3/8 to G2.

The standard diaphragm is supplied in NBR. On demand it can be supplied in FKM or EPDM.

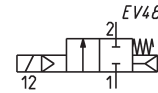
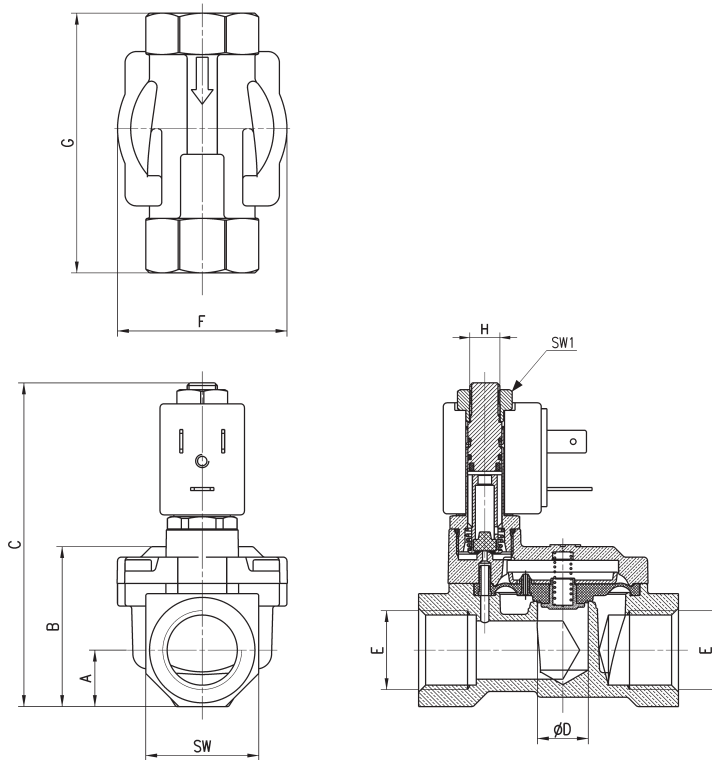

TABLE NOTE:

* = choose the suitable solenoid (see the table on page 2/1.30.03).



Mod.	Function	Orifice ØD (mm)	Kv [m³/h with water]	Pressure min-max (bar)	A	B	C	E	F	G	H	SW	SW1
CFB-A23L-R1-*	2/2 NC	11.5	1.7	0.1 + 15 [AC / DC]	12	32.5	78.5	G3/8	41.9	57	M8x0.75	24	13
CFB-A24N-R1-*	2/2 NC	13.5	3.8	0.1 + 15 [AC / DC]	15	39.7	85.7	G1/2	45	69	M8x0.75	30	13
CFB-A25P-R1-*	2/2 NC	18	5	0.2 + 15 [AC / DC]	18	46.5	92.7	G3/4	54.4	74	M8x0.75	36	13
CFB-A26R-R1-*	2/2 NC	26	11	0.2 + 12 [AC / DC]	22.5	59.8	104.5	G1	71	93	M8x0.75	45	13
CFB-A27T-R1-*	2/2 NC	32	17	0.4 + 12 [AC / DC]	27.5	73.5	130	G1 1/4	86.6	111	G1/8	55	14
CFB-A28X-R1-*	2/2 NC	45	27	0.4 + 10 [AC / DC]	31	85	138.3	G1 1/2	110	138	G1/8	62	14
CFB-A29Z-R1-*	2/2 NC	50	36	0.4 + 10 [AC / DC]	37.5	98.8	152	G2	110	145	G1/8	75	14

Products designed for industrial applications. General terms and conditions for sale are available on www.camozzi.com.

New
Indirectly operated 2/2 NO solenoid valve

The pilot of these indirectly operated solenoid valves controls the diaphragm position through a differential pressure. These valves are therefore particularly suitable for controlling high fluid flow rates and require very low working pressures. Ports: from G3/8 to G2.

The standard diaphragm is supplied in NBR. On demand it can be supplied in FKM or EPDM.

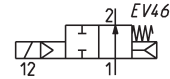

TABLE NOTE:

* = choose the suitable solenoid (see the table on page 2/1.30.03).



2

CONTROL

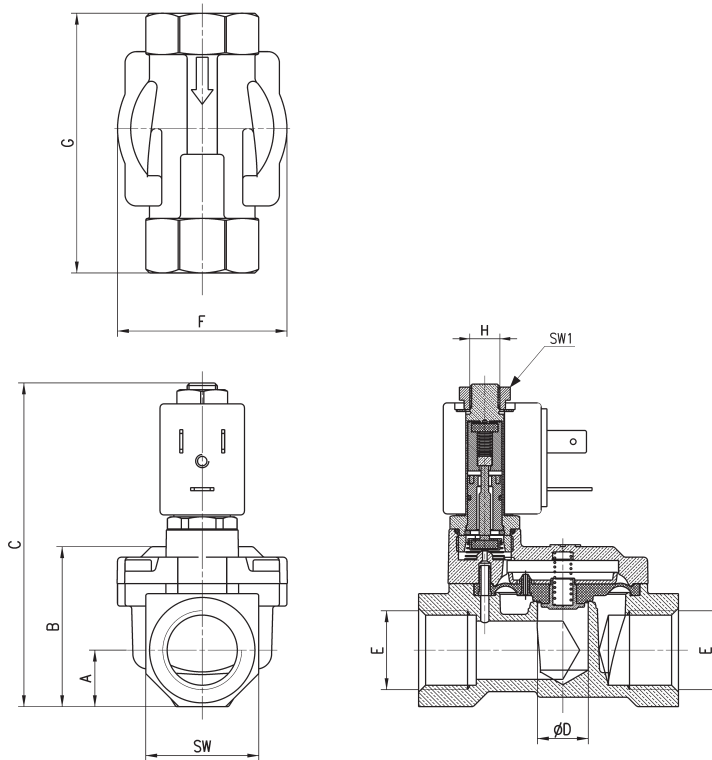

Mod.	Function	Orifice ØD (mm)	Kv [m³/h with water]	Pressure min-max (bar)	A	B	C	E	F	G	H	SW	SW1
CFB-A13L-R1-*	2/2 NO	11.5	1.7	0.1 + 15 [AC / DC]	12	32.5	78.5	G3/8	41.9	57	M8x0.75	24	13.5
CFB-A14N-R1-*	2/2 NO	13.5	3.8	0.1 + 15 [AC / DC]	15	39.7	85.7	G1/2	45	69	M8x0.75	30	13.5
CFB-A15P-R1-*	2/2 NO	18	5	0.2 + 15 [AC / DC]	18	46.5	92.7	G3/4	54.4	74	M8x0.75	36	13.5
CFB-A16R-R1-*	2/2 NO	26	11	0.2 + 12 [AC / DC]	22.5	59.8	104.5	G1	71	93	M8x0.75	45	13.5
CFB-A17T-R1-*	2/2 NO	32	17	0.4 + 12 [AC / DC]	27.5	73.5	130	G1 1/4	86.6	111	G1/8	55	14
CFB-A18X-R1-*	2/2 NO	45	27	0.4 + 10 [AC / DC]	31	85	138.3	G1 1/2	110	138	G1/8	62	14
CFB-A19Z-R1-*	2/2 NO	50	36	0.4 + 10 [AC / DC]	37.5	98.8	152	G2	110	145	G1/8	75	14