

High Precision & Torque Control
LS Vector Inverter

Starvert **iV5**

2.2~37kW 3 Phase 200~230V
2.2~375kW 3 Phase 380~460V



Automation Equipment





" The optimum solution "
The vector control LS Starvert iV5 series
provides a full satisfaction
for all the needs.

'We guarantee, your satisfaction Will be beyond your expectation'
LS Starvert iV5 series realizes the high precision vector control in entire operational area and its highly precise speed control guarantees a superb control stability in the elevator controls.



05	06	09	13	15	16	24	28
Features	Model & Type	Wiring	I/O Board	Shifts between each groups and codes in the Loader	Function Codes Table	Braking Unit and Resistor	Fault Solution and Check
	07	11	14	26	29		
	Standard Specification	Terminal Function	Loader Use	Dimension	Basic configuration		

FULL 10 out of service ▲ ▼

LS starvert iV5 series features the versatile and user-friendly interface and extended functional innovation.

"LS inverter is to be evolved through our state-of-the-art technologies from now on"





LS Inverter iV5 Series

Autotuning

In the application which requires a high torque at low speed, the electrical parameters of motor should be properly set for an optimal operation. LS Vector Controlled Inverter of iV5 has two types of autotuning, which are standstill type and rotation type, respectively.

■ Standstill type Autotuning

This unique technology of LS allows the autotuning operation to be performed even with the motor shaft directly connected to the load. Especially, this standstill type autotuning is very useful in the lift application because it does not require removal of brake coupling connected to the motor.

■ Rotation type Autotuning

This type of autotuning has been widely used for the vector control inverter. As the name implies, this requires the motor shaft to be free of the coupling for a proper operation.

Various communication interfaces

iV5 provides various communication interface such as RS 485, DeviceNET, Profibus-DP and Modbus-RTU. When LS PLC is used as an upper level controller, it can be easily interfaced to the iV5.

Extended function card (ENC_DIV, DIAO and ELIO)

Option card for the encoder pulse division (ENC_DIV) supports the encoder with open collector output and can divide the encoder pulse up to 1/128.

Digital input and Analog signal output card (DIAO) can receive the binary speed command from PLC or other upper level controller and has 4 channels of analog signal output.

ELIO card enables the lift application software to be available for an optimized lift operation.

Standard compliances

All starvert iV5 series comply with cUL and UL (Type1) standards.

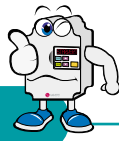

Model & Type

Applicable Motor ranges	200V Series	400V Series
2.2kW (3HP)	SV022iV5-2DB(MD)	SV022iV5-4DB(MD)
3.7kW (5HP)	SV037iV5-2DB(MD)	SV037iV5-4DB(MD)
5.5kW (7.5HP)	SV055iV5-2DB(MD)	SV055iV5-4DB(MD)
7.5kW (10HP)	SV075iV5-2DB(MD)	SV075iV5-4DB(MD)
11kW (15HP)	SV110iV5-2DB(MD)	SV110iV5-4DB(MD)
15kW (20HP)	SV150iV5-2DB(MD)	SV150iV5-4DB(MD)
18.5kW (25HP)	SV185iV5-2DB(MD)	SV185iV5-4DB(MD)
22kW (30HP)	SV220iV5-2DB(MD)	SV220iV5-4DB(MD)
30kW (40HP)	SV300iV5-2	SV300iV5-4
37kW (50HP)	SV370iV5-2	SV370iV5-4
45kW (60HP)		SV450iV5-4
55kW (75HP)		SV550iV5-4
75kW (100HP)		SV750iV5-4
90kW (120HP)		SV900iV5-4
110kW (150HP)		SV1100iV5-4
132kW (175HP)		SV1320iV5-4
160kW (215HP)		SV1600iV5-4
220kW (300HP)		SV2200iV5-4
280kW (375HP)		SV2800iV5-4
315kW (420HP)		SV3150iV5-4
375kW (500HP)		SV3750iV5-4

■ Mold Type**Note1*
 ■ Mold/Press Type
 ■ Press Type

SV220iV5-2DB

INPUT	200 - 230V	3phase
	69A	50/60Hz
OUTPUT	0 - Input V	3phase
	60A	0.1 - 400Hz
	20HP/15kW	

0010222100155

LS Industrial Systems Co., Ltd. Made in Korea

- Inverter type
- Input power specification
Rated capacity
- Output power specification
Operation frequency and rated output
- Bar-code
- Serial number

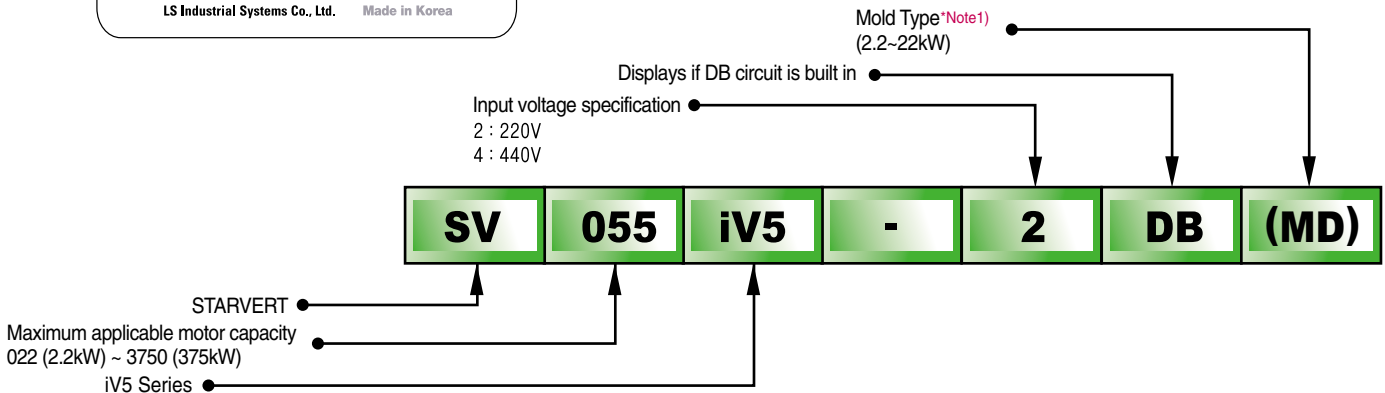

**Note1*) Mold type products are available soon



Standard Specification

200V Class Specifications

Type : SV [] [] iV5-2(DB)		022	037	055	075	110	150	185	220	300	370
Maximum applicable motor ranges	[HP]	3	5	7.5	10	15	20	25	30	40	50
	[kW]	2.2	3.7	5.5	7.5	11	15	18.5	22	30	37
Rated output	Capacity[kVA] * Note2)	4.5	6.1	9.1	12.2	17.5	22.5	28.2	33.1	46	55
	Rated current [A]	12	16	24	32	46	59	74	88	122	146
	Output speed	0 ~ 3600 (rpm)									
	Output voltage	200 ~ 230V * Note3)									
Rated input	Voltage	3 ∅ 200 ~ 230V (-10% ~ +10%)									
	Frequency	50 ~ 60Hz (±5%)									
Weight [Kg(lbs)]		6	6	14	14	28	28	28	28	42	42

400V Class Specifications

Type : SV [] [] iV5-4(DB)		022	037	055	075	110	150	185	220	300	370
Maximum applicable motor ranges	[HP]	3	5	7.5	10	15	20	25	30	40	50
	[kW]	2.2	3.7	5.5	7.5	11	15	18.5	22	30	37
Rated output	Capacity[kVA]	4.5	6.1	9.1	12.2	18.3	22.9	29.7	34.3	46	57
	Rated current [A]	6	8	12	16	24	30	39	45	61	75
	Output speed	0 ~ 3600 (rpm)									
	Output voltage	380 ~ 460V * Note3)									
Weight [Kg(lbs)]		6	6	14	14	28	28	28	28	42	42

Type : SV [] [] iV5-4(DB)		450	550	750	900	1100	1320	1600	2200	2800	3150	3750
Maximum applicable motor ranges	[HP]	60	75	100	120	150	175	215	300	373	420	500
	[kW]	45	55	75	90	110	132	160	220	280	315	375
Rated output	Capacity[kVA]	70	85	116	140	170	200	250	329	416	468	557
	Rated current [A]	91	110	152	183	223	264	325	432	546	614	731
	Output speed	0 ~ 3600 (rpm)										
	Output voltage	380 ~ 460V * Note3)										
Rated input	Voltage	3 ∅ 380 ~ 460V (-10% ~ +10%)										
	Frequency	50~60Hz (±5%)										
Weight [Kg(lbs)]		63	63	68	98	98	122	122	175	243	380	380

Mold type products' electric specifications are same as upper parts (2.2/3.7kW follow below table) * Note4)

Type: SV [] [] iV5-2/4DB(MD)		055	075	110	150	185	220
Weight [Kg(lbs)]		7.7	7.7	13.7	13.7	20.3	20.3

*Note1) It represents the output capacity 05 maximum applicable motor in case LG-OTIS 4pole motor is used.

*Note2) Rated capacity (= $\sqrt{3}VI$) is calculated based on 220V for 200V class, 440V for 400V class.

*Note3) Maximum output voltage cannot be generated greater then specified input voltage.

*Note4) Available Soon



Standard Specifications

Common Specifications

Item		Specification
Circuit type		IGBT adopted voltage type inverter
Control	Control type	Speed sensor use vector type control Open loop control: V/F control (90-220kW)
	Frequency / Speed control accuracy	Analog: $\pm 0.2\%$ of maximum command speed ($25 \pm 10^\circ\text{C}$) Digital: $\pm 0.01\%$ of maximum command speed ($0-40^\circ\text{C}$)
	Frequency / Speed resolution	Analog: $\pm 0.05\%$ of maximum command speed Digital: 0.01% of maximum command speed
	Vector	Response speed torque control 50Hz 3%
	V / F	V / F pattern torque Boost Linear, Square, User V/F Manual torque boost(0-20%), Automatic torque boost
	Speed ACC/DEC	Time setup Combination Pattern 0.00-6000.0 sec (Time unit can be set) 4 combined of Acc/Dec eleration time Linear, S-Curve
Braking	Braking type Braking torque Braking resistor	Dynamic braking using external resistor 150% An external braking resistor is required
Input	Speed setting	Digital setting Multi-step-speed setup by digital input Analog input setting of -10~10V or 4~20mA Setting by options
	Analog input	3Channels (AI1, AI2, AI3) -10 ~ 10V, 4 ~ 20mA, 10 ~ 0V, 20 ~ 4mA, motor NTC (selectable) Selectable among 9 different multi-function analog inputs
	Digital input	FX, RX, BX, RST, P1 ~ P7 Multi function input terminal (P1~P7) can be selected among 27 functions.
Output	Analog output	2-Channel (AO1, AO2) -10 ~ 10V output Selective among 31 multi-function analog output functions
	Digital output	Multi function digital output: 2channels (1A-1B, 2A-2B) Fault digital output: 1channel (30A-30C, 30B-30C)
	Open collector output	1channel (OCI/EG)
Protection function		Over current, Over/Low voltage, Inverter overheat, Inverter thermal sensor open, Motor over heat, Motor thermal sensor open, Over speed, IGBT gate blocking (BX), Fuse open, Trip by unusual external signal, Encoder error, Communication error, Electronic thermal, Stall prevention (V/F), Over load(V/F), Inverter over load
Environment	Installation environment	Indoor, free of corrosive gas and direct sunlight
	Ambient temperature	-10 ~ 40C (Non frozen condition)
	Ambient humidity	Below RH90% (Dew free)
	Cooling method	Forced cooling by FAN
	Altitude / Vibration	Below 1000 meters/ above sea level 5.9% ϵ (= 0.6G)

Wiring



2.2 ~ 22kW (200V/400V)

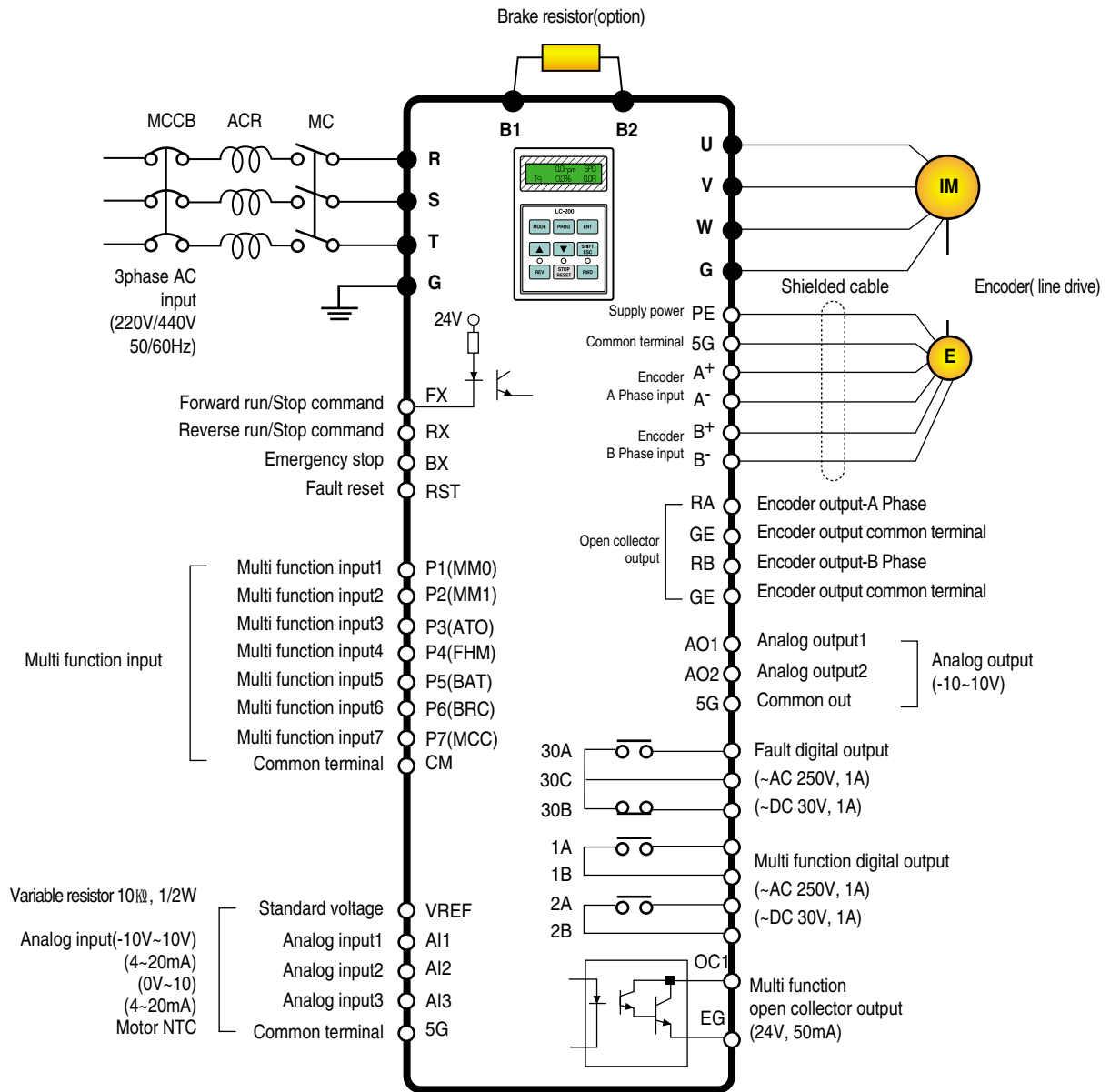

Note ● : Power terminal ○ : control terminal

Wiring



30 ~ 37kW (200V)
30 ~ 375kW (400V)

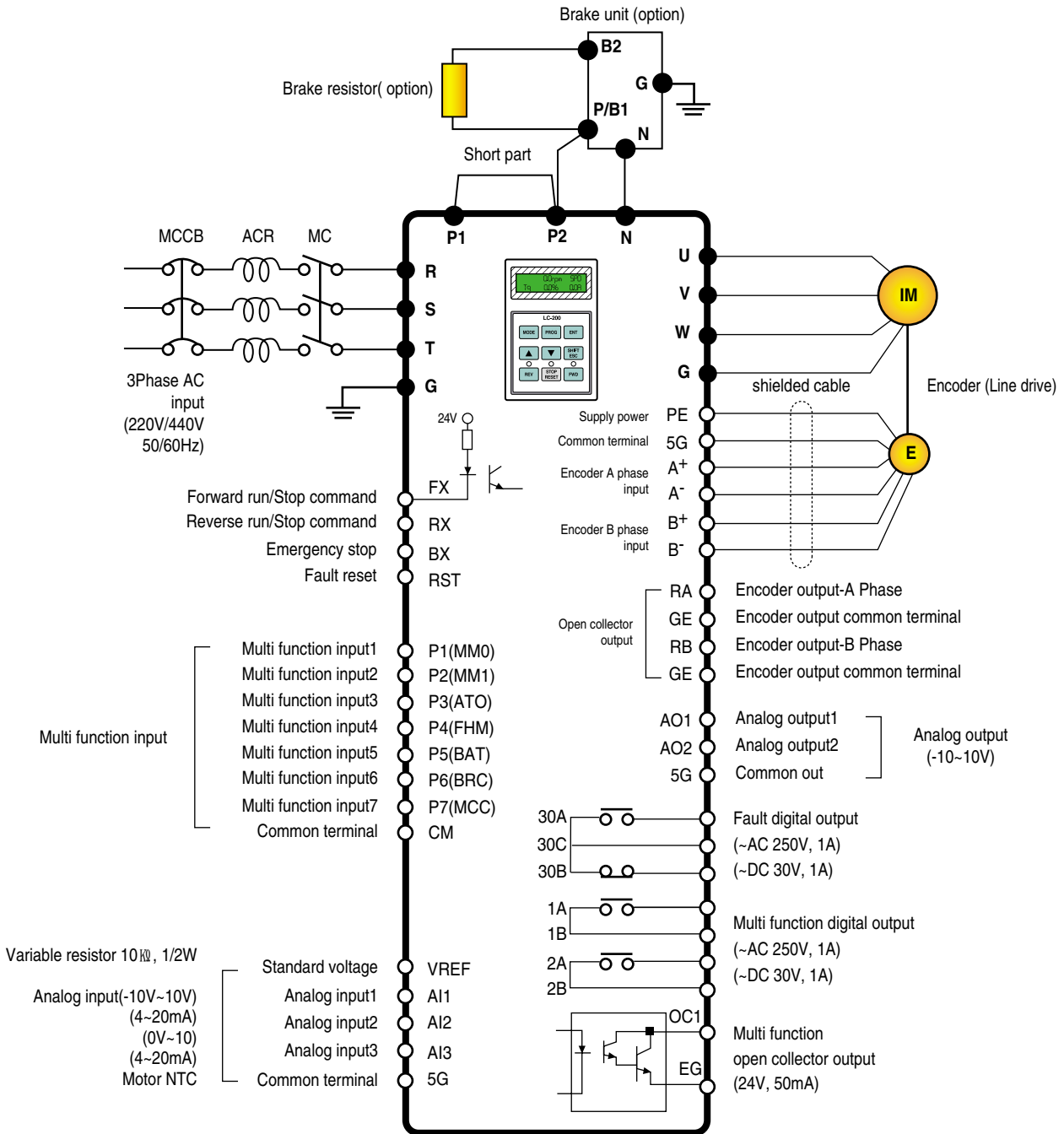

Note) ● : Power terminal ○ : control terminal



Terminal Function

■ Power Terminal

Display	Name	Description
R, S, T	AC Input	3Phase AC input connection 1) 200V: 200~230V, 50/60Hz 2) 400V: 300~460V, 50/60Hz
U, V, W	output	Cable connection of 3 phase induction motor
G	Earth	Inverter frame earth terminal
B1, B2	Braking resistor	Braking resistor connection
P1, P2	DC reactor and Braking unit	DC reactor, braking unit and DC link common connection terminal
P	DC Link(+-) terminal	DC Link common connection terminal
N	DC Link(-) terminal	Braking unit and DC link common terminal

■ Control Circuit Terminals

Item	Display	Name	Description
Digital input	FX RX RST P1(MMO)	Forward run command Reverse run command Fault reset	<ul style="list-style-type: none"> • "ON" when tied to CM terminal • Stops when FX and RX are ON/OFF simultaneously • Clears the fault condition only when the fault state is removed • Selectable among the following 27 functions: (Multi step speed selection 1/2/3, JOG run, MOP up/down/Save/Clear, Analog hold, Main drive, Second function, Speed Acc/Dec time selection, 3-wire operation, External default signal B contact point, Forward rotation prevention, Process PI disable, Timer input, Soft start cancellation, ASR PI Gain selection, ASR P.PI selection, Flux reference selection, Pre-excitation, Speed/Torque control selection, Torque limit use, Torque bias • "ON" in case of connection between CM and digital
	CM VREF	COMMON	
Analog input	A11	Analog setting power	<ul style="list-style-type: none"> • Variable resistor use standard voltage(+10V):10Ω • Voltage input(-10~10V), current input(4~20mA) The motor NTC input is selectable • Selectable among following 9 functions; (Speed reference, Torque reference, Torque bias, Torque limit, Process PI control reference, Process PI controller feedback, Draw reference, Motor NTC input) • Jumper set up use AC voltage input → A11, A12: Open , A13:Left of switch
	A12	voltage input Current input	
	A13	voltage input Motor NTC input	<ul style="list-style-type: none"> • Jumper set to use as voltage input → A11,A12: Short • With motor NTC(OTIS-LG Motor) input, switch direction setup → A13: Right of switch
	5G	COMMON	<ul style="list-style-type: none"> • Analog input COMMON terminal



Terminal Function

Control Circuit Terminals

Classification	Display	Name	Description	
Encoder Input	PE 5G	Encoder power	+5V Line drive power(Jumper set required) 0V	
	A+ A-	Encoder A phase signal	<ul style="list-style-type: none"> • A and B phase signals of line drive encoder • To use the line drive type encoder, the "P5 pin" of I/O PCB JP2 should be shorted and then the JP1 switch should be pulled down to "LD" direction • Jumper setup (factory default) 	
	B+ B-	Encoder B phase signal		
	PE 5G	Encoder power	+15V Open collector power (Jumper setup is required) 0V	
	PA PB	Encoder A phase signal Encoder B phase signal	<ul style="list-style-type: none"> • A and B phase signals of complementary and open collector type signals • Short the "P15 pin" of I/O PCB JP2 and then pull up the JP1 switch to "OC" 	
	Encoder output	RA GE RB GE	Encoder output-phase A Encoder output common terminal Encoder output-phase B Encoder output common terminal	<ul style="list-style-type: none"> • Encoder phase A and B output signal (Open collector type)
Analog Output		AO1 AO2	Analog output1 Analog output2	<ul style="list-style-type: none"> • Output -10V~+10V • Selection among following 31 items; (Motor speed, Speed reference1~2, Torque reference1~2,Torque current volume Flux reference, Flux reference volume, Inverter output current, Inverter output voltage, Motor temperature, DC voltage..)
		5G	COMMON	
Digital Output		1A 1B 2A 2B	Multi function digital output1(contact point A) Multi function digital output2(contact point B)	<ul style="list-style-type: none"> • Selectable among following 14 items; (Zero speed detection, speed detection(polarity valid), speed detection(rotation direction invalid), Speed reach, Speed matching, arbitrary torque detection Torque limit feature, Motor overheating signal, Inverter overheating signal, Low voltage feature, Inverter run signal, Inverter regeneration signal, Inverter run function, Timer output)
	OC1 EG	Multi function open collector output		
	30A 30B 30C	Fault signal A contact point Fault signal B contact point COMMON	<ul style="list-style-type: none"> • Activates when the faults occur • Not available in emergency stop • Common for A and B digital output 	

Control Circuit Terminal

Control Terminal Feature

- Control Terminal Panel Arrangement(Standard Type(SIO) - Non insulated type)

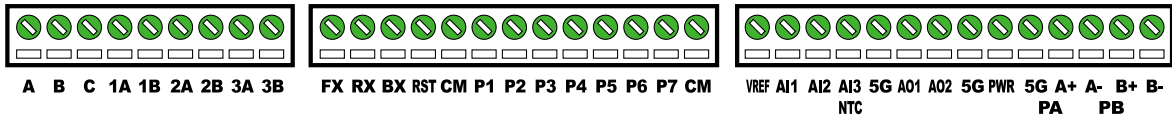

I/O Board



1) Encoder wiring and Jumper setup (+15V Complementary or Open collector)

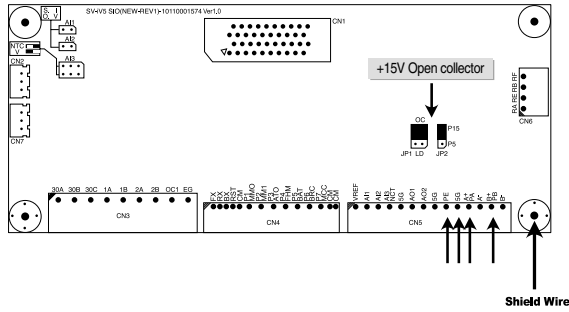

I/O PCB version : V1.0

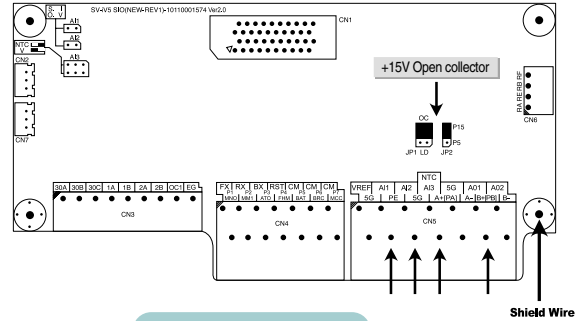

I/O PCB version : V2.0

2) Encoder wiring and Jumper setup (+5V Line drive)

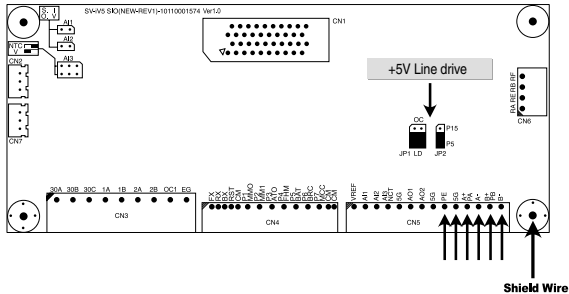

I/O PCB version : V1.0

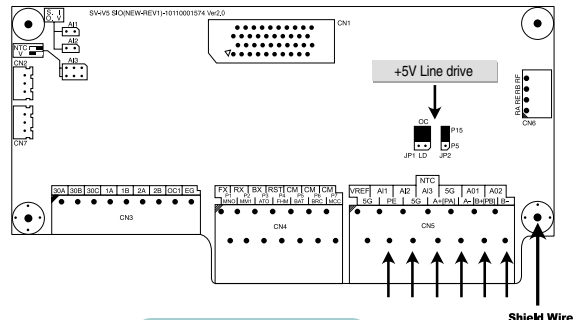

I/O PCB version : V2.0

3) Analog Input Jumper setup (Voltage/ Current/ Motor NTC inputs)

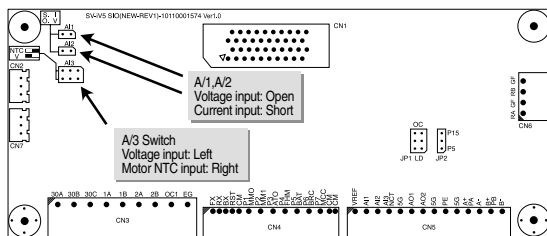

I/O PCB version : V1.0

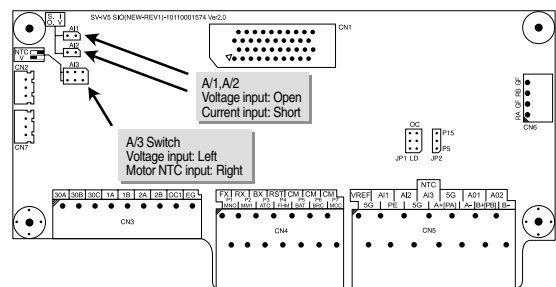

I/O PCB version : V2.0



Warning

- Do not change the jumper set for the encoder type during operation. The Jumper type change during operation results in a serious system damage. Jumpers should be set properly before the inverter operation.
- The NTC input of the analog input 3(AI3) is only available with OTIS-LG motors. Use of different type of NTC may cause the motor damage due to overheating.



Loader Use

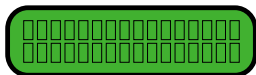

■ Data and status display



- Shift between function groups
- Shifting from group code to the upper code



- Function code shift
- Shift to next function code
- Data increase in set up mode



- Reverse run command key
- Only available, with loader operation
- LED is turned ON with reverse run
- Blinks during Acc/Deceleration of reverse run



- Shift to function code
- Shift to previous code
- Data is decreased in set up mode

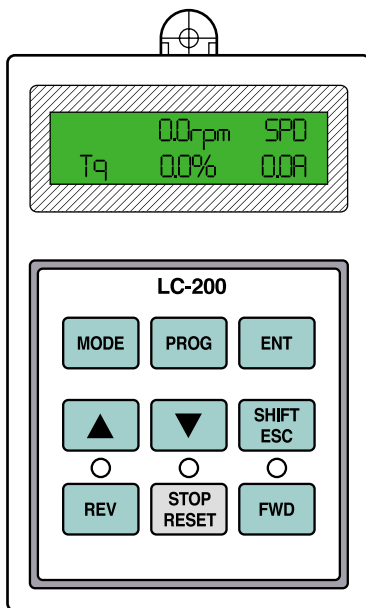

- Data set up start



- Data set up completion



- Decimal point shift
- Only available in case of data setup



- Forward run command key
- Only available with loader operation
- LED is turned on with forward operation
- Blinks during Acc/Deceleration of forward operation



- Stop command
- Available with the loader operation
- LED is turned on when inverter stops its operation
- Blinks when fault occurs
- Reset
- Fault reset

Loader Use Instruction

Classification	Display	Function Name	Function
KEY	MODE	Mode Key	shift between groups. shift from a group code to upper code.
	PROG	Program Key	Parameter setting value change.
	ENT	Enter Key	Saving altered setting values.
	▲ (up)	Up Key	Shift between codes and increase the parameter value.
	▼ (down)	Down Key	Shift between codes and decrease the parameter value.
	Shift/ESC	Shift/ESC Key	In case of set up mode, it is operated with the shift key. Operation with ESC key in non-set up mode.
	REV	Reverse run	Reverse run key.
LED	(REV)	Reverse run key	Turns on at reverse operation. Blinks while the inverter is on Acc/Deceleration and then turns on the constant speed operation.
	(STOP/RESET)	Stop/Fault display	Turns off when inverter stops operation. Blinks when fault occurs.
	(FWD)	Forward Run Display	Turns on during forward operation. Acc/Deceleration running modes blink the lamp and it is turned on in the forward operation.



Shifts Between Each Groups and Codes in the Loader

■ Shifts between each groups and codes in LCD loader

The [MODE] key is used for transfer to the other group and the [▲UP] and the [▼down] keys are used to move up and down in the same group.

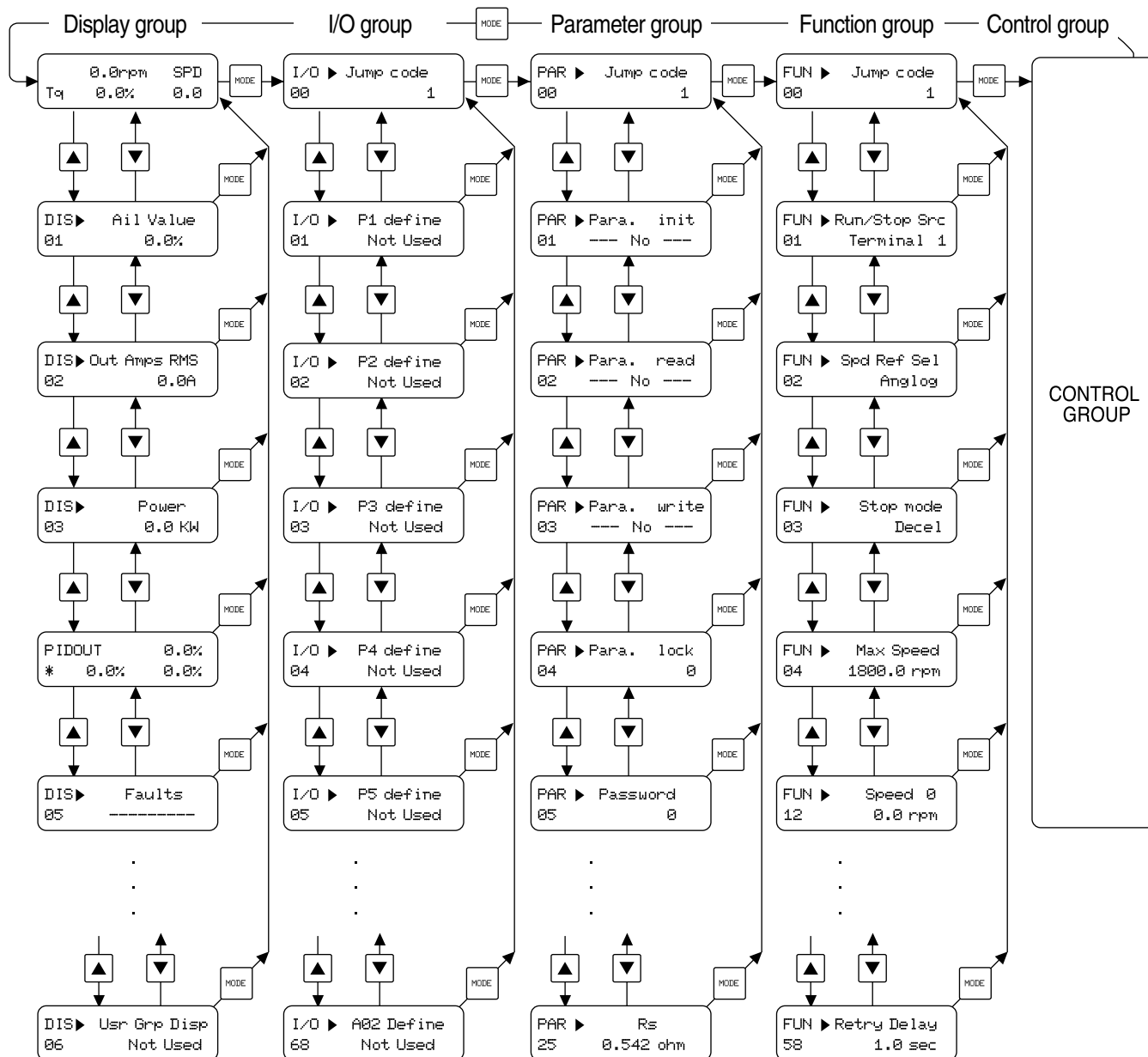

● The user group and the second group are omitted between shifts of each group.



Function Codes Table

■ Display Group [DIS_][][]

DIS Group	Code No.	Code Name	LCD Display Message	Setting Data			*Note1) R
				Range	Unit	Default	
	DIS_00	Motor speed/Control mode Actual torque/current	0.0rpm SPD Tq 0.0% 0.0A				
	DIS_01	User selection display 1	Ai1 Value Ai2 Value Ai3 Value PreRamp Ref PostRamp Ref ASR Inp Ref Output freq Motor Speed Speed Dev ARS Out Torque Bias Torque Limi Torque Ref IqeRef Iqe Flux ref Ide ref Ide ACR_Q Out ACR_D Out VdeRef VqeRef Out Amps RMS Out Volt RMS Power DC Bus Volt Proc PI Ref Proc PI F/B Proc PI Out Mot Temp Inv Temp Inv i2t Inv it MP Output Ctrl Mode S/W Version Run Time Terminal In Terminal Out Run Status		% % % rpm rpm rpm rpm rpm rpm % % % % A A % A A V V V V A V kW V % % % deg deg % % %	PreRamp Ref	Yes
	DIS_02	User selection display 2	Refer to DIS_01			DC Bus Volt	Yes
	DIS_03	User selection display 3	Refer to DIS_01			Terminal In	Yes
	DIS_04	Process PID output Ref / FB	PIDOut 0.0% * xx.x% 0.0%				
	DIS_05	Fault feature display	Faults				
	DIS_06	User group display setup	Usr Grp Disp	Not used Dis+User Grp Display ALL		Not used	Yes

*Note1) Parameter set up possibility during inverter operation
(Yes: Set up allowed No: Set up not allowed)

■ I/O Group [I/O_][][]

I/O Group	Code No.	Code Name	LCD Display Message	Setting Data			R
				Range	Unit	Default	
	I/O_00	Function code selection	Jump Code	1 ~ 7.5			Yes
	I/O_01	Definition of multi-function input terminal P1	P1 Define	Not used Speed-L Speed-M Speed-H Jog Speed Mop Up Mop Down Mop Save Mop Clear Analog Hold Main Drive 2nd Func Xcel-L Xcel-H 3-Wire Ext Trip-B Prohibit FWD Prohibit REV Proc PID Dis Timer Input SoftStrtCncl ASR Gain Sel ASR P/PI Sel Flux Ref Sel PreExcite Spd/Trq Sel Use Max Trq Use Trq Bias		Not used	No
	I/O_02	Definition of multi-function input terminal P2	P2 Define	Refer to I/O-01		Not used	No
	I/O_03	Definition of multi-function input terminal P3	P3 Define	Refer to I/O-01		Not used	No
	I/O_04	Definition of multi-function input terminal P4	P4 Define	Refer to I/O-01		Not used	No
	I/O_05	Definition of multi-function input terminal P5	P5 Define	Refer to I/O-01		Not used	No
	I/O_06	Definition of multi-function input terminal P6	P6 Define	Refer to I/O-01		Not used	No
	I/O_07	Definition of multi-function input terminal P7	P7 Define	Refer to I/O-01		Not used	No
	I/O_08	Reverse operation of multi-function input terminal	Neg Function	0000000 ~ 1111111	bit	0000000	No
	I/O_09	LPF time constant of terminal input	Terminal LPF	0 ~ 2000		5	Yes
	I/O_10	Reverse run of multi-function input terminal	Neg Function, Out	00000~ 11111	bit	00000	No
	I/O_11	Definition of multi-function analog input Ai1	Ai1 define	Not used Speed Ref Proc PID Ref Proc PID F/B Draw Ref Torque Ref Flux Ref Torque Bias Torque Limit		Not used	Yes Yes Yes Yes Yes Yes Yes Yes

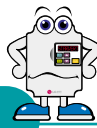

Function Codes Table

■ I/O Group [I/O_][][]

I/O Group	Code No.	Code Name	LCD Display Message	Setting Data			R
				Range	Unit	Default	
	I/O_12	Definition of multi-function analog input Ai1	Ai1 Source	-10~10V 4~20mA 10~0V 20~4mA		-10~10V	Yes
	I/O_13	Gain of multi-function analog input Ai1	Ai1 Gain	0.00~250.00	%	100.00	Yes
	I/O_14	Bias of multi-function analog input Ai1	Ai1 Bias	100.00 ~ Ai1 Gain	%	0.00	Yes
	I/O_15	Time constant of multi-function analog input Ai1	Ai1 LPF	0 ~ 2000	ms	0	Yes
	I/O_16	Definition of multi-function analog input Ai2	Ai2 Define			Not used	Yes
	I/O_17	Type definition of multi-function analog input Ai2	Ai2 Source			-10~10V	Yes
	I/O_18	Gain of multi-function analog input Ai2	Ai2 Gain	Refer to I/O_10 ~		100.00	Yes
	I/O_19	Bias of multi-function analog input Ai2	Ai2 Bias	I/O_15		0.00	Yes
	I/O_20	Time constant of multi-function analog input LPF Ai2	Ai2 LPF			0	Yes
	I/O_21	Definition of multi-function analog input Ai3	Ai3 Define			Not used	Yes
	I/O_22	Type definition of multi-function analog input Ai3	Ai3 Source	Refer to I/O_11 ~		-10~10V	Yes
	I/O_23	Gain of multi-function analog input Ai3	Ai3 Gain	I/O_15		100.00	Yes
	I/O_24	Bias of multi-function analog input Ai3	Ai3 Bias	(I/O_20: motor NTC selectable)		0.00	Yes
	I/O_25	Time constant of multi-function analog input Ai3	Ai3 LPF			0	Yes
	I/O_41	Definition of multi-function auxiliary output terminal AX1	AX1 Define	Not used INV Ready Zero Spd Det Spd Det. Spd Det(ABS) Spd Arrival Timer Out LV Warn Run Regenerating Mot OH Warn Inv OH Warn Spd Agree Trq Det. Trq Lmt Det.		Not used	Yes
	I/O_42	Definition of multi-function auxiliary output terminal AX2	AX2 Define	Equal to I/O_40		Not used	Yes
	I/O_43	Definition of multi-function auxiliary output terminal OC1	OC1 Define	Equal to I/O_40		Not used	Yes
	I/O_46	Fault relay mode (A,B,C terminals)	Relay Mode	000 ~ 111	bit	011	Yes
	I/O_47	Zero speed detect level	ZSD Level	0.0 ~ 480.0	rpm	10.0	Yes
	I/O_48	Zero speed detect band	ZSD Band	0.1 ~ 10.0	%	0.5	Yes
	I/O_49	Arbitrary Speed detect level	SD Level	-3600 ~ 3600	rpm	0	Yes
	I/O_50	Arbitrary Speed detect band	SD Band	0.1 ~ 10.0	%	0.5	Yes
	I/O_51	Detect band of speed reach	SA Band	0.1 ~ 10.0	%	0.5	Yes

■ I/O Group [I/O_][][]

I/O Group	Code No.	Code Name	LCD Display Message	Setting Data			R
				Range	Unit	Default	
	I/O_53	Arbitrary Torque detect level	TD Level	0.0 ~ 250.0	%	0.0	Yes
	I/O_54	Arbitrary Torque detect band	TD Band	0.1 ~ 10.0	%	0.5	Yes
	I/O_55	Timer on delay time	TimerOn Dly	0.1 ~ 3600.0	sec	0.1	Yes
	I/O_56	Timer off delay time	TimerOff Dly	0.1 ~ 3600.0	sec	0.1	Yes
	I/O_57	Overload warning level	OL Level	30 ~ 250	%	150	Yes
	I/O_58	Overload warning time	OL Time	0 ~ 30	sec	10	Yes
	I/O_59	Overload trip selection	OLT Select	Yes / No		Yes	Yes
	I/O_60	Overload trip level	OLT Level	50 ~ 250	%	180	Yes
	I/O_61	Overload trip time	OLT Time	0 ~ 60	sec	60	Yes
	I/O_62	Inverter overheat detect temperature	IH Warn Temp	50 ~ 85	deg	75	Yes
	I/O_63	Inverter overheat detect band	IH Warn Band	0 ~ 10	deg	5	Yes
	I/O_64	Motor overheat detect temperature	MH Warn Temp	75 ~ 150	deg	140	Yes
	I/O_65	Motor overheat detect band	MH Warn Band	0 ~ 10	deg	5	Yes
	I/O_66	Definition of multi-function analog output AO1	AO1 Define	Not used Ai1 Value Ai2 Value Ai3 Value PreRamp Ref PostRamp Ref ASR Inp Ref Motor Speed Speed Dev ASR Out Torque Bias Torque Limit Torque Ref IqeRef Iqe Flux Ref IdeRef Ide ACR_Q Out ACR_D Out VdeRef VqeRef Out Amps RMS Out Volt RMS Power DC Bus Volt Proc PI Ref PROC PI F/B Proc PI Out Mot Temp Inv Temp Inv i2t		Not used	Yes
	I/O_67	Gain of multi-function analog output AO1	AO1 Gain	0.0 ~ 500.0	%	100.0	Yes
	I/O_68	Bias of multi-function analog output AO1	AO1 Bias	-100.0 ~ I/O_67	%	0.0	Yes
	I/O_69	Definition of multi-function analog output AO2	AO2 Define	Refer to I/O_66 ~ I/O_68		Not used	Yes
	I/O_70	Gain of multi-function analog output AO2	AO2 Gain	Refer to I/O_66 ~ I/O_68	%	100.0	Yes
	I/O_71	Bias of multi-function analog output AO2	AO2 Bias	Refer to I/O_66 ~ I/O_68	%	0.0	Yes

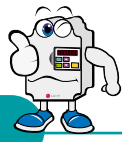

Function Codes Table

Parameter Group [PAR_][][]

PAR Group	Code No.	Code Name	LCD Display Message	Setting Data			R
				Range	Unit	Default	
	PAR_00	Function code selection	Jump Code	1 ~ 31			Yes
	PAR_01	Initializing parameters as Factory default value	Para. init	No, All Groups DIS, I/O PAR, FUN CON, EXT USR, 2ND, E/L		No	No
	PAR_02	Reading all function codes	Para. read	No Yes		No	No
	PAR_03	Writing all function codes	Para. write	No Yes		No	No
	PAR_04	Prohibiting function codes change	Para. lock	0 ~ 255		0	Yes
	PAR_05	Password	Password	0 ~ 9999		0	Yes
	PAR_07	Motor capacity selection	Motor select	0 (2.2) 1 (3.7) 2 (5.5) 3 (7.5) 4 (11.0) 5 (15.0) 6 (18.5) 7 (22.0) 8 (30.0) 9 (37.0) 10 (45.0) 11 (55.0) 12 (75.0) 13 (90.0) 14 (110.0) 15 (132.0) 16 (160.0) 17 (220.0) 18 (280.0) 19 (315.0) 20 (375.0) 21 (User Define)	kW		No
	PAR_08	User motor selection	User motor sel	1.5~220.0	kW	5.5	No
	PAR_09	Motor cooling method	Cooling Mtd	Self-cool, Forced-cool		Forced-cool	Yes
	PAR_10	Number of encoder pulse	Enc Pulse	360 ~ 4096		1024	No
	PAR_11	Encoder direction selection	Enc Dir Set	A Phase Lead B Phase Lead		A Phase Lead	No
	PAR_12	Encoder error check method	Enc Err Chk	Yes, No		Yes	No
	PAR_13	Encoder LPF time constant	Enc LPF	0 ~ 100	ms	1	Yes
	PAR_14	Encoder error detect time	EncFaultTime	0.00 ~ 10.00	sec	0.00	No
	PAR_15	Encoder error standard speed rate	EncFaultPerc	0.0 ~ 50.0	%	25.0	No
	PAR_17	Motor rated speed	Rated Speed	100.0 ~ 3600.0	rpm	1800.0	No
	PAR_18	Motor rated volt	Rated Volt	120 ~ 560	V		No
	PAR_19	Number of poles of motor	Pole Number	2 ~ 12		4	Yes
	PAR_20	Motor efficiency	Efficiency	70.0 ~ 100.0	%		Yes
	PAR_21	Motor rated slip	Rated Slip	10 ~ 250	rpm		Yes
	PAR_22	Motor rated current	Rated-Curr	1.0 ~ 450.0	A		Yes
	PAR_23	Auto tuning method selection	AutoTuneType	Standstill Rotational		Rotational	No
	PAR_24	Auto tuning type selection	Auto Tuning	None ALL1 ALL2 Encoder Test Rs Tuning Lsigma Flux Curr Ls Tuning Tr Tuning		None	No
	PAR_25	Tuning torque	Tune Torue	10.0 ~ 100.0	%	70	Yes
	PAR_26	Motor flux current	Flux Curr	0.0 ~ PAR_21	A		Yes
	PAR_27	2nd constant	Tr	30 ~ 3000	ms		Yes
	PAR_28	Stator inductance	Ls	0.00 ~ 500.00	mH		Yes
	PAR_29	Stator leakage Inductance	Lsigma	0.00 ~ 100.00	mH		Yes
	PAR_30	Stator resistance	Rs	0.000 ~ 5.000	ohm		Yes

*Note) In the case of setting up the PAR_22(Auto tuning) as "standstill", the procedure of PAR_23 (Auto tuning type selection) is displayed as following steps,
None → All1 → Rs Tuning → Lsigma → If/Tr/Ls tune

■ Function Group [FUN_[] []]

FUN Group	Code No.	Code Name	LCD Display Message	Setting Data			R
				Range	Unit	Default	
	FUN_00	Function code selection	Jump Code	1~62			Yes
	FUN_01	RUN/STOP Command selection	RUN/STOP Src	Terminal 1 Terminal 2 Keypad Option		Terminal 1	No
	FUN_02	Speed reference selection	Spd Ref Sel	Analog Keypad 1 Keypad 2 Option		Keypad 1	No
	FUN_03	Stop mode	Stop Mode	Decel Free-run		Decel	No
	FUN_04	Motor Maximum speed	Max Speed	400.0~3600.0	rpm	1800.0	No
	FUN_12	Multi-step speed0	Speed 0	0.0~Max speed	rpm	0.0	Yes
	FUN_13	Multi-step speed1	Speed 1	0.0~Max speed	rpm	0.0	Yes
	FUN_14	Multi-step speed2	Speed 2	0.0~Max speed	rpm	0.0	Yes
	FUN_15	Multi-step speed3	Speed 3	0.0~Max speed	rpm	0.0	Yes
	FUN_16	Multi-step speed4	Speed 4	0.0~Max speed	rpm	0.0	Yes
	FUN_17	Multi-step speed5	Speed 5	0.0~Max speed	rpm	0.0	Yes
	FUN_18	Multi-step speed6	Speed 6	0.0~Max speed	rpm	0.0	Yes
	FUN_19	Multi-step speed7	Speed 7	0.0~Max speed	rpm	0.0	Yes
	FUN_20	JOG speed	JOG Speed	0.0~Max speed	rpm	100.0	Yes
	FUN_21	Dwell speed	Dwell speed	0.0~Max speed	rpm	100.0	Yes
	FUN_22	Dwell time	Dwell time	0.00~30.000	rpm	100.0	Yes
	FUN_36	"S" curve rate 1 in acceleration	Acc S Start	0.0 ~ 50.0	%	0.0	No
	FUN_37	"S" curve rate 2 in acceleration	Acc S End	0.0 ~ 50.0	%	0.0	No
	FUN_38	"S" curve rate 1 in deceleration	Dec S Start	0.0~50.0	%	0.0	No
	FUN_39	"S" curve rate 2 in deceleration	Dec S End	0.0~50.0	%	0.0	No
	FUN_40	Acc time1	Acc Time-1	0.00~6000.0	sec	2.00	Yes
	FUN_41	Dec time1	Dec Time-1	0.00~6000.0	sec	2.00	Yes
	FUN_42	Acc time2	Acc Time-2	0.00~6000.0	sec	3.00	Yes
	FUN_43	Dec time2	Dec Time-2	0.00~6000.0	sec	3.00	Yes
	FUN_44	Acc time3	Acc Time-3	0.00~6000.0	sec	4.00	Yes
	FUN_45	Dec time3	Dec Time-3	0.00~6000.0	sec	4.00	Yes
	FUN_46	Acc time4	Acc Time-4	0.00~6000.0	sec	5.00	Yes
	FUN_47	Dec time4	Dec Time-4	0.00~6000.0	sec	5.00	Yes
	FUN_48	Zero-speed dec time use	Use 0 Dec T	Yes No		No	Yes
	FUN_49	Zero speed dec time	0 Dec Time	0.00~6000.0	sec	0.00	Yes
	FUN_51	Emergency stop dec time	BX Time	0.0~6000.0	sec	0.0	Yes
	FUN_52	Initial motor magnetizing time	PreExct Time	0~10000	ms	0	No
	FUN_53	Hold time	Hold Time	100~10000	ms	1000	No
	FUN_54	Electronic thermal selection	ETH Select	No Yes		No	Yes
	FUN_55	Electronic thermal 1 minute level	ETH 1 min	FUN_54~200	%	150	Yes
	FUN_56	Electronic thermal successive operation level	ETH Cont	50~FUN_53	%	100	Yes
	FUN_57	Inverter switching frequency	PWM Freq	2.5~10.0	kHz	10.0	No
	FUN_58	Selecting power-on start	Power-on Run	No Yes		Yes	Yes
	FUN_59	Selecting run after trip reset	RST Restart	No Yes		Yes	Yes
	FUN_60	Number of auto restart	Retry Number	0~10		0	Yes
	FUN_61	Auto retry delay time	Retry Delay	0.0~60.0	sec	1.0	Yes
	FUN_62	Restart delay time after stop command	Restart time	0.00~10.00	sec	0.00	No
	FUN_63	Overspeed error detect level	Overspd level	100.0~130.0	%	120.0	No
	FUN_64	Overspeed error detect time	Overspd time	0.00~2.00	sec	0.00	No

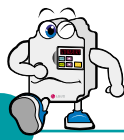

Function Codes Table

■ Control Group [CON_[][]]

CON Group	Code No.	Code Name	LCD Display Message	Setting Data			R
				Range	Unit	Default	
	CON_00	Function code selection	Jump Code	1 ~ 47			Yes
	CON_01	Control mode selection	Control Mode	Speed Torque		Speed	No
	CON_02	Inverter application mode selection	Application	General Vect/ Elevator		General Vect	No
	CON_03	ASR P Gain1	ASR P Gain1	0.0 ~ 200.0	%	5.0	Yes
	CON_04	ASR I Gain1	ASR I Gain1	0 ~ 50000	ms	3000	Yes
	CON_05	ASR input LPF time constant1	ASR LPF1	0 ~ 20000	ms	0	Yes
	CON_06	ASR P Gain2	ASR P Gain2	0.0 ~ 200.0	%	50.0	Yes
	CON_07	ASR I Gain2	ASR I Gain2	0 ~ 50000	ms	300	Yes
	CON_08	ASR input LPF time constant 2	ASR LPF2	0 ~ 20000	ms	0	Yes
	CON_09	Ramp time in gain switching	ASR Ramp	10 ~ 10000	ms	1000	Yes
	CON_10	Gain switching speed	ASR TarSpd	0.0 ~ 3600.0	rpm	0.0	No
	CON_11	Process PID command(Loader)	Proc PID Ref	-100.0 ~ 100.0	%	0.0	Yes
	CON_12	Process PID position standard	Proc Posi Ref	0 ~ 65535	%	0	No
	CON_13	Process PID P gain	Proc PID Kp	0.0 ~ 999.9	%	0.0	Yes
	CON_14	Process PID I gain	Proc PID Kt	0.0 ~ 100.0	%	0.0	Yes
	CON_15	Process PID D gain	PROC PID Kd	0.0 ~ 100.0	%	0.0	Yes
	CON_16	Process PID positive limit	Proc PID Lmt	-100.0 ~ 100.0	%	100	Yes
	CON_17	Process PID negative limit	Proc Neg Lmt	-100.0 ~ 100.0	%	100	Yes
	CON_18	Process PID output LPF time constant	Proc Out LPF	0 ~ 500	ms	0	Yes
	CON_19	Process PID output gain	Proc OutGain	-250.0 ~ 250.0	%	0.0	Yes
	CON_20	Process PID output enable	Proc PID Enb	Disable Enable Terminal		Disable	No
	CON_21	Process PID Hold time	PID Hold time	0~10000	ms	0	No
	CON_22	Draw set up percentage	Draw %	-100.0 ~ 100.0	%	0.0	Yes
	CON_23	Droop control percentage	Droop %	0.0 ~ 100.0	%	0.0	Yes
	CON_24	Droop control minimum speed	Droop MinSPd	0.0 ~ 3600.0	rpm	0.0	Yes
	CON_25	Droop control minimum torque	Droop MinTrd	0.0 ~ 100.0	%	0.0	Yes
	CON_26	Torque reference value selection	Trq Ref Src	None Analog Option		None	No
	CON_27	Torque reference (Loader)	Trq Ref	-180.0~180.0	%	0.0	Yes
	CON_28	Torque limit definition	Trq Lmt Src	Kpd Kpd Kpd Kpd Kpd Ax Kpd Ax Kpd Kpd Ax Ax Ax Kpd Kpd Ax Kpd Ax Ax Ax Kpd Ax Ax Ax Opt Opt Opt		Kpd Kpd Kpd	No
	CON_29	Forward torque limit	Pos Trq Lmt	0.0 ~ 250.0	%	150.0	Yes
	CON_30	Reverse torque limit	Neg Trq Lmt	0.0 ~ 250.0	%	150.0	Yes
	CON_31	Regenerative torque limit	Reg Trq Lmt	0.0 ~ 250.0	%	150.0	Yes
	CON_32	Torque bias selection	Trq Bias Src	None Analog Keypad Option		None	No
	CON_33	Torque bias volume	Trq Bias	-150.0 ~ 150.0	%	0.0	Yes
	CON_34	Torque bias compensation volume of friction factor	Trq Bias FF	-150.0 ~ 150.0	%	0.0	Yes
	CON_35	Torque balance percentage	Trq Bias F	0.0 ~ 100.0	%	50.0	Yes
	CON_49	Speed search selection	Speed search	0000~1111 (Bit set up)		0100	No

■ User Group [USR_[][]]

User Group	Code No.	Code Name	LCD Display Message	Control Method		I/O Option		Setting Data			R
				Vector	V/F	SIO	EIO	Range	Unit	Default	
	USR_00	Function code selection	Jump Code					1 ~ 67			Yes
	USR_01	Initializing as applicable field's initial value	Macro Init	○	○	○	○	User Define E/L		User Define	No
	USR_02	User data save	User Save	○	○	○	○	Yes No		No	No
	USR_03	Recall saved user data	User Recall	○	○	○	○	Yes No		No	No
	USR_04	User group data	User Grp	○	○	○	○				No

■ 2nd function group [2nd_[][]]

2nd Group	Code No.	Code Name	LCD Display Message	Setting Data			R
				Range	Unit	Default	
	2nd_00	Function code selection	Jump Code	1 ~ 33			Yes
	2nd_01	2nd motor control mode	2nd Ctl Mode	Speed Torque		Speed	No
	2nd_02	2dn motor maximum speed	2nd Max Spd	400.0 ~ 3600.0	rpm	1800.0	No
	2nd_04	2nd motor multi-step speed 0	2nd Spd 0	0.0 ~ 2nd_02	rpm	0.0	Yes
	2nd_05	"S" curve rate 1 in the 2nd motor acceleration	2nd Acc S St	0.0 ~ 50.0	%	0.0	No
	2nd_06	"S" curve rate 2 in the 2nd motor acceleration	2nd Acc S Ed	0.0 ~ 50.0	%	0.0	No
	2nd_07	"S" curve rate 1 in the 2nd motor deceleration	2nd Dec S St	0.0 ~ 50.0	%	0.0	No
	2nd_08	"S" curve rate 2 in the 2nd motor deceleration	2nd Dec S Ed	0.0 ~ 50.0	%	0.0	No
	2nd_09	The 2nd motor acceleration time	2nd Acc time	0.00 ~ 6000.0	sec	10.00	Yes
	2nd_10	The 2nd motor deceleration time	2nd Dec time	0.00 ~ 6000.0	sec	10.00	Yes
	2nd_11	The 2nd motor cooling method	2nd Cool Mtd	Self-cool Forced-cool		Self-cool	Yes
	2nd_12	Number of encoder pulse of 2nd motor	2nd Enc #	360 ~ 4096		1024	No
	2nd_13	The 2nd motor encoder direction selection	2nd Enc dir	A(B)Phase Lead		A Phase Lead	No
	2nd_14	The 2nd motor encoder error check method	2nd Enc chk	Yes No		Yes	No
	2nd_15	The 2nd motor encoder LPF Time Constant	2nd Enc LPF	0 ~ 100	ms	1	Yes
	2nd_17	The 2nd motor rated speed	2nd RatedSpd	300.0 ~ 3600.0	rpm	1800.0	No
	2nd_18	The 2nd motor rated volt	2nd R-Volt	120 ~ 560	V		No
	2nd_19	The 2nd motor number of poles	2nd Pole #	2 ~ 12		4	No
	2nd_20	The 2nd motor efficiency	2nd Mot Eff	70 ~ 100	%		Yes
	2nd_21	The 2nd motor rated slip	2nd R-Slip	10 ~ 250	rpm		Yes
	2nd_22	The 2nd motor rated current	2nd R-Curr	1.0 ~ 450.0	A		Yes
	2nd_23	The 2nd motor flux current	2nd Flx Cur	70% of 0.0-2nd_22	A		Yes
	2nd_24	The 2nd motor 2nd time constant	2nd Mot Tr	30 ~ 3000	ms		Yes
	2nd_25	The 2nd motor stator inductance	2nd Mot Ls	0.00 ~ 500.00	mH		Yes
	2nd_26	The 2nd motor stator leakage factor	2nd Mot sLs	0.00 ~ 100.00	mH		Yes
	2nd_27	The 2nd motor stator resistance	2nd Mot Rs	0.000 ~ 5.000	ohm		Yes
	2nd_32	The 2nd motor electronic thermal 1 minute level	2nd Eth 1min	100 ~ 150	%	150	Yes
	2nd_33	The 2nd motor electronic thermal continuous operation level	2nd Eth cont	50 ~ 150	%	100	Yes

*Note) The auto firing method of the 2nd motor should be Same with the (PAR_22) and (PAR_23).



Braking Unit and Resistor

1. SV055iV5-2/4 ~ SV220iV5-2/4 : Built-in Brake Unit

1) Braking resistor specifications in capacity

Resistance values in the table shown below are calculated based on the 150%, 5%ED standard. In case of 10%ED use, resistor with double rated value should be used. resistors' rated watt.

Type	Applicable Inverters	Capacity(5%ED)	
		[Ω]	[W]
BR0800W020J	SV 055iV5-2 DB	20	800
BR01200W015J	SV 075iV5-2 DB	15	1200
BR2400W010J	SV 110iV5-2 DB	10	2400
BR2400W008J	SV 150iV5-2 DB	8	2400
BR3600W005J	SV 185iV5-2 DB	5	3600
BR3600W005J	SV 220iV5-2 DB	5	3600
BR1000W085J	SV 055iV5-4 DB	85	800
BR1200W060J	SV 075iV5-4 DB	60	1200
BR2400W040J	SV 110iV5-4 DB	40	2400
BR2400W030J	SV 150iV5-4 DB	30	2400
BR3600W020J	SV 185iV5-4 DB	20	3600
BR3600W020J	SV 220iV5-4 DB	20	3600

▶ ED 100sec standard.

▶ Resistance value is based on the self-cooling standard.

2) Brake resistor wiring

Brake resistor has attached a temperature detectable sensor for fire protection.

See below when in use.

Brake resistor terminal blocks	Inverter terminals	Operation
B1, B2	P, BR	
P7, CM	One of the multi function input terminals, out of P1~P7, of control terminals board is used as defining "External trip signal contact B"	The contact is ON in normal temperature and opens in overheat.

2. SV300iV5-2/4 ~ SV550iV5-2/4, SV750iV5-4 ~ SV2200iV5-4 : An external, unit is attached.

● 200V Series

Applicable inverters	SV300iV5-2	SV370iV5-2
Brake unit type	SV037DBH-2	
Brake resistor	3 Ω, 5kW	
Applicable motors	30KW	37KW

● 400V Series

Applicable inverters	SV300iV5-4	SV370iV5-4	SV450iV5-4	SV550iV5-4	SV750iV5-4	SV900iV5-4~ SV1600iV5-4
Brake unit type	SV037DBH-4		SV075DBH-4			SV075DB
4x2units						
Brake resistor	12 Ω 5kW		12 Ω, 5kWx2units		12 Ω, 5kWx4units	

● Terminal functions

Terminal name	Description
P/B1	Connection to inverter terminal P2 or P and B2 of braking resistor.
N	Connection to inverter terminal N
B2	Connection to brake resistor B2
G	Ground terminal
IN+	Control connection lint(used when SLAVE MODE)
IN-	Control connection lint(used when SLAVE MODE)
OUT+	Control connection lint(used when MASTER MODE)
OUT-	Control connection lint(used when MASTER MODE)
30A/30B/30C	Fault signal output terminal, when the protection function of braking unit operates. 30A : Contact A, 30B : Contact B, 30C COMMON

● Display functions

Displayed item	Description
POWER	Main power in braking unit turns on the POWER LED. Generally the braking unit is wired to Inverter so, once the input main power of inverter is on the POWER LED of braking unit turns on.
RUN	While braking unit operates its normal operation by the motor regenerative energy, the RUN LED blinks.
OHT	During the braking operation, if the braking unit heat sink is overheated and exceeds its limited value, the overheat protection function operates. This blocks the braking unit signal and then turns on the OHT LED.
OCT	During the braking operation, if over current flows in the main circuit of braking unit inside then the over current protection function is operated in order to prevent the circuit from over current. The TURN ON signal of braking unit is blocked and then turns on the OCT LED.

■ Terminal Block and Braking Unit

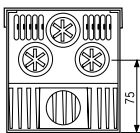
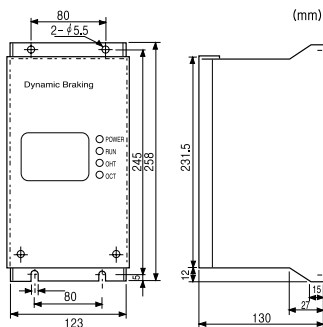

Weight : 2.45kg

Main circuit terminal block

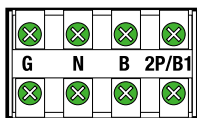

Control circuit terminal

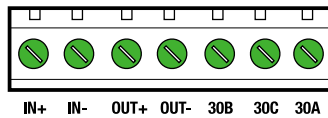

■ Wiring

1) Single use of Braking unit

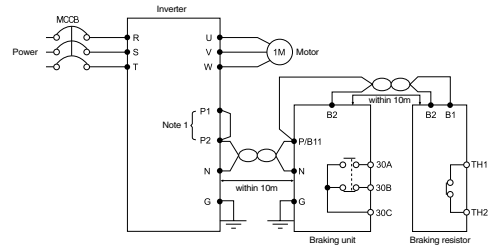

2) Double use of Braking unit

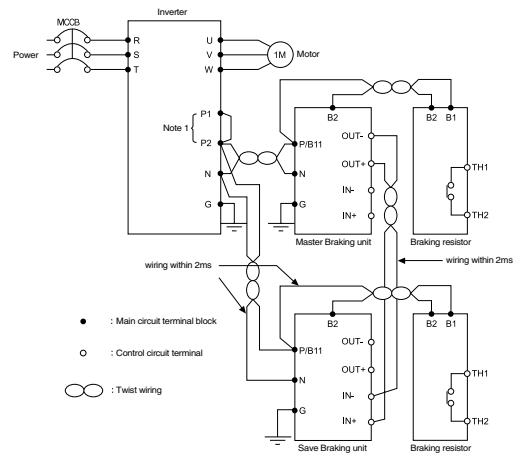

■ Combination of the Braking units and Braking resistors

● 30~37kW(200V/400V)

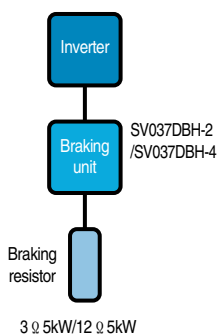

● 45~55kW(200V)

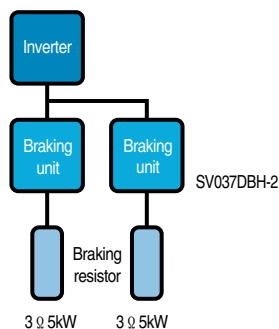

● 45~75kW(400V)

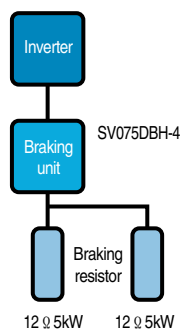

● 90~160kW(400V)

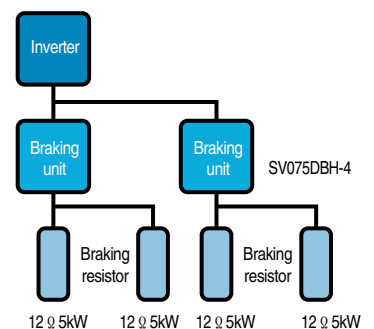

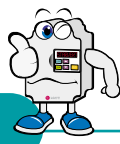

Dimension

1) 2.2 ~ 22kW (200V/400V), Mold Type (Available Soon)

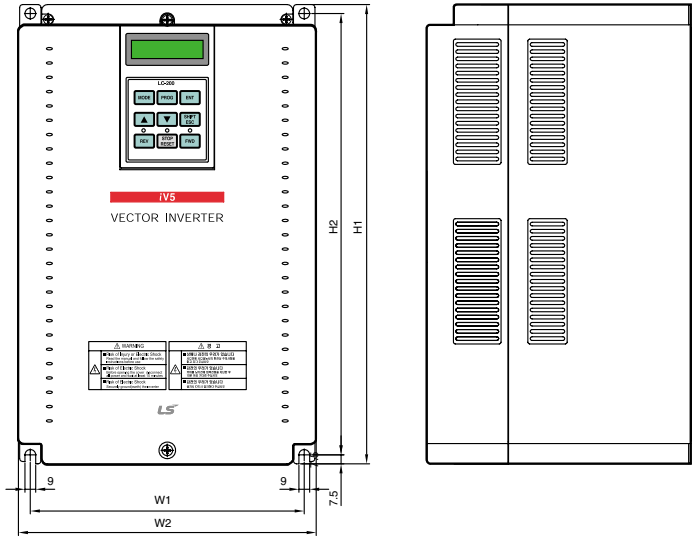
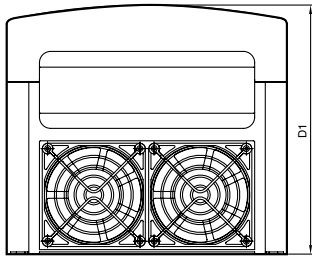

● Dimensions of each capacity (mm[inches])

Inverter Model	W1	W2	H1	H2	D1
SV022iV5-2/4DB (MD)			284	269	207
SV037iV5-2/4DB (MD)	200	180	[11.18]	[10.69]	[8.15]
SV055iV5-2/4DB (MD)	[7.87]	[7.09]	355	340	202
SV075iV5-2/4DB (MD)			[13.97]	[13.38]	[7.95]
SV110iV5-2/4DB (MD)	250	230	385	370	221
SV150iV5-2/4DB (MD)	[9.84]	[9.06]	[15.16]	[14.57]	[8.70]
SV185iV5-2/4DB (MD)	304	284	460	445	254
SV220iV5-2/4DB (MD)	[11.97]	[11.18]	[18.11]	[17.52]	[10.00]

2) 5.5 ~ 22kW (200V/400V)

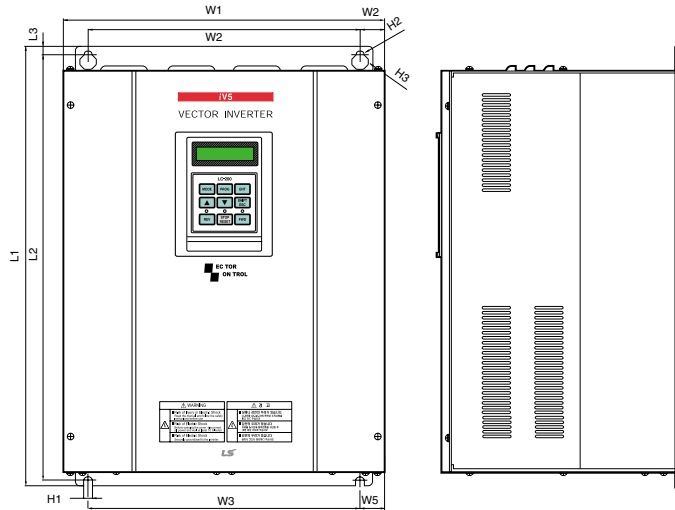
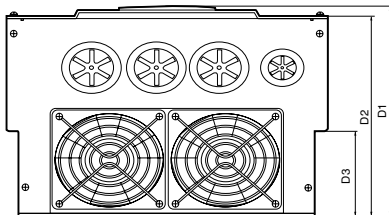

● Dimensions of each capacity (mm[inches])

Inverter Model	W1	W2	W3	W4	W5	L1	L2	L3	D1	D2	D3	H1	H2	H3
SV055iV5-2/4DB	234.4	180	180	27.2	27.2	406.2	391.2	7.5	221.1	209.5	75	6	∅ 6	∅ 12
SV075iV5-2/4DB	[9.22]	[7.08]	[7.08]	[1.07]	[1.07]	[15.9]	[15.4]	[0.29]	[8.7]	[8.24]	[2.95]	[0.23]		
SV110iV5-2/4DB														
SV150iV5-2/4DB	335	284	284	25.5	25.5	526	509	10	248.6	237	100	7	∅ 7	∅ 14
SV185iV5-2/4DB	[13.1]	[11.1]	[11.1]	[1.00]	[1.00]	[20.7]	[20.0]	[0.39]	[9.78]	[9.33]	[3.93]	[0.27]		
SV220iV5-2/4DB														

3) 30 ~ 37kW (200V)
30 ~ 75kW (400V)

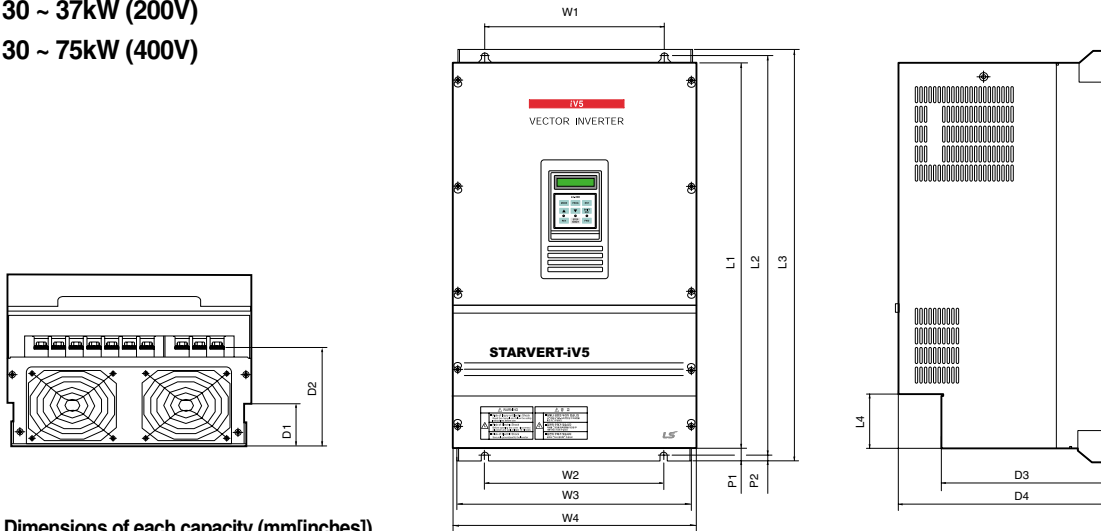

● Dimensions of each capacity (mm[inches])

Inverter Model	W1	W2	W3	W4	L1	L2	L3	D1	D2	D3	D4	P1	P2
SV300iV5-2/4	270	270	319.2	350	635	660	680	120	197	256.6	308.2	16.9	8
SV370iV5-2/4	[10.6]	[10.6]	[12.5]	[13.7]	[25.0]	[26.0]	[26.7]	[4.72]	[7.76]	[10.1]	[12.1]	[0.66]	[0.31]
SV450iV5-4	275	275	359.6	375	730.6	758.5	780	82.3	189.3	259	326	24.5	10.5
SV550iV5-4	[10.8]	[10.8]	[14.1]	[14.7]	[28.7]	[29.8]	[30.7]	[3.24]	[7.45]	[10.2]	[12.8]	[0.90]	[0.41]

4) 90 ~ 160kW (400V)

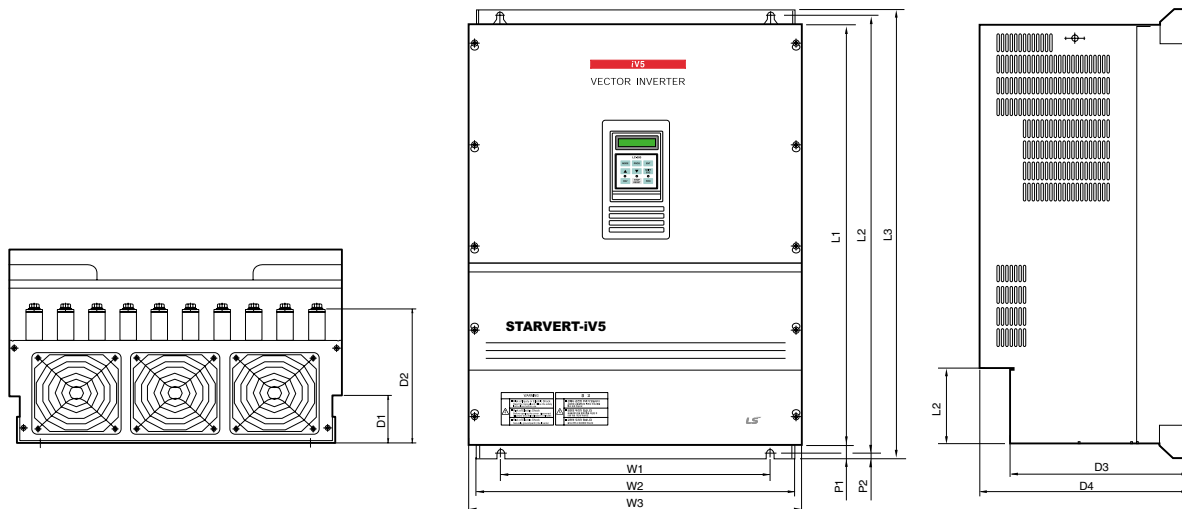

● Dimensions of each capacity (mm[inches])

Inverter Model	W1	W2	W3	L1	L2	L3	D1	D2	D3	D4	P1	P2
SV900iV5-4	430	507	530	729	760	780	83.2	234.6	286.2	335	23.5	8.5
SV1100iV5-4	[16.9]	[19.9]	[20.8]	[28.7]	[29.9]	[30.7]	[3.27]	[9.23]	[11.2]	[13.2]	[0.92]	[0.33]
SV1320iV5-4	430	507	530	949	980	1000	95.2	231.6	298	345	23.5	8.5
SV1600iV5-4	[16.9]	[19.9]	[20.8]	[37.3]	[38.5]	[39.3]	[3.75]	[9.12]	[11.7]	[13.5]	[0.92]	[0.33]

5) 220kW (400V)

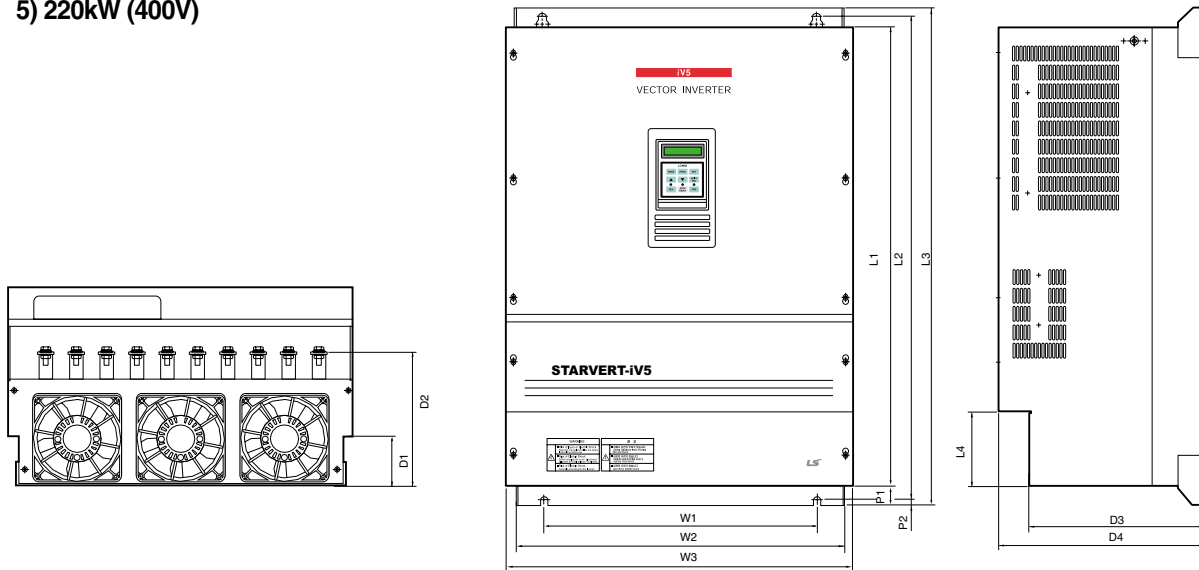

● Dimensions of each capacity (mm[inches])

Inverter Model	W1	W2	W3	L1	L2	L3	L4	D1	D2	D3	D4	P1	P2
SV2200iV5-4	540 [21.26]	649 [25.55]	680 [26.77]	922 [36.3]	968.5 [38.13]	998 [39.29]	150 [5.91]	100.2 [3.94]	271 [10.67]	343 [13.5]	403 [15.87]	38 [1.49]	12 [0.47]

6) 285 ~ 375kW (400V)

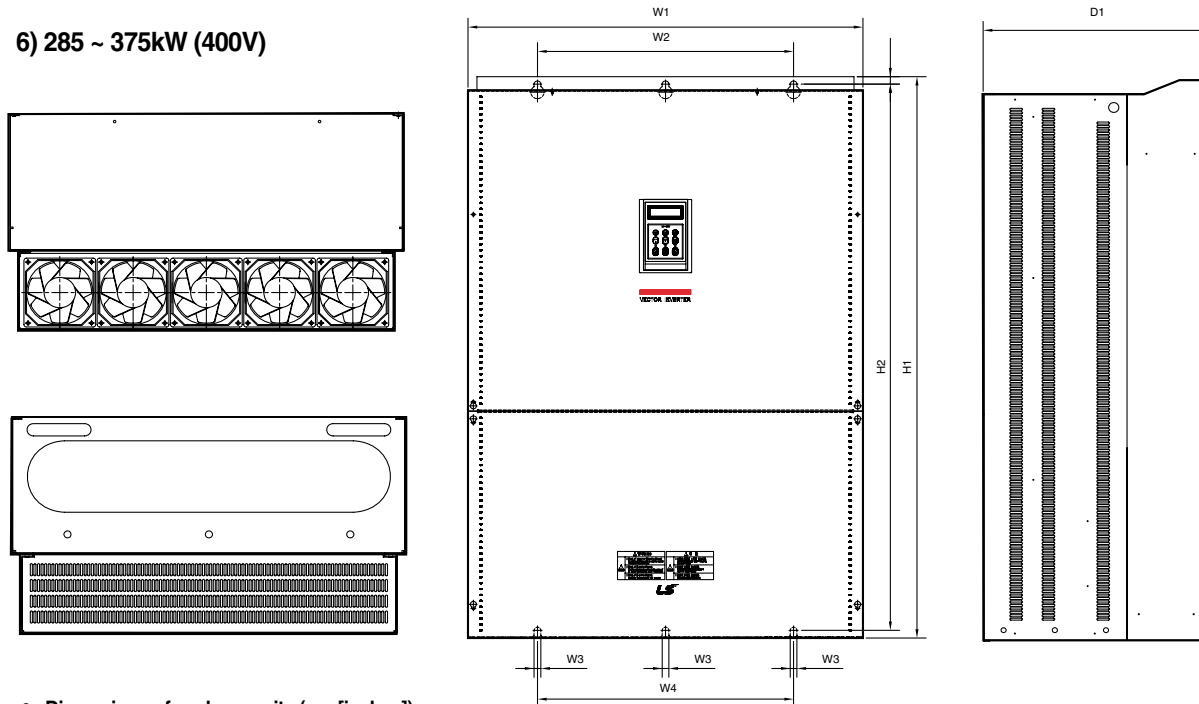

● Dimensions of each capacity (mm[inches])

Inverter Model	W1	W2	W3	W4	D1	H1	H2
SV2800iV5-4	772 [30.39]	500 [19.69]	13 [0.51]	500 [19.69]	1140.5 [44.90]	1110 [43.70]	442 [17.40]
SV3150iV5-4	922	580	14	580	1302.5	1271.5	495
SV3750iV5-4	[6.30]	[22.83]	[0.55]	[22.83]	[51.28]	[50.06]	[19.49]

Fault Solution and Check

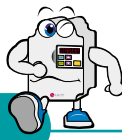

Fault Display

Inverter faults activate its protection functions which enable the alarm operation and each fault status is displayed in the loader. Refer to table shown below for the LCD loader displays.

Protection function	LCD Display	Description
Over current	OC-U OC-V OC-W	Inverter turns off its output when the output current of the inverter flows more than 200% of the inverter rated current.
Ground fault protection	Ground Fault	Inverter turns off its output when a ground fault occurs and the ground fault current is more than the internal setting value of the inverter. Over current trip function may protect the inverter when a ground fault occurs due to a low ground fault resistance.
Over voltage protection	Over Voltage	Inverter turns off its output if the DC voltage of the main circuit increases higher than the rated value (200V series : 400V DC, 400V Series : 800V DC) when the motor decelerates or when regenerative energy flows back to the inverter due to a regenerative load. This fault can also occur due to a surge voltage generated at the power supply system.
Low voltage protection	Low Voltage	Inverter turns off its output if the DC voltage is below the rated level(200V Series: 200VDC, 400V Series : 400Vdc) because insufficient torque or over heating of the motor can occurs when the input voltage of the inverter drops.
Over load trip (Over load protection)	Over Load	Inverter turns off its output if the output current of inverter is over 180% of motor rated current and over load trip time. (only applicable to over 90kW inverters and also V/F control mode)
Fuse open	Fuse Open	Inverter turns off its output by opening the fuse when something is wrong with the main circuit IGBT to protect the wiring from being damaged from short currents
Inverter over heat	InvOver Heat	Inverter turns off its output if the heat sink over heats due to a damaged cooling fan or an alien substance in the cooling fan by detecting the temperature of the heat sink.
Inverter NTC thermister open	InvThem OP	Inverter turns off its output if the NTC Thermister, which measures the temperature of inverter, is open.
Motor over heat	MotOver Heat	Inverter turns off its output if the motor is over-heated to protect the motor. This protective function prevents the motor from over heat.
Motor NTC thermister open	MotThem OP	Inverter turns off its output if the NTC Thermister, which measures the motor temperature, is open.
Electronic thermal	E-Thermal	Internal electronic thermal of the inverter determines the over heating of the motor. If the motor is overloaded the inverter turns off the output. Inverter cannot protect the motor when driving a multi-pole motor or when driving multiple motors, so consider thermal relays or other thermal protective devices for each motor.
External fault	Ext Trip-B	This is used if the user wants to turn off the inverter output due to external fault signal.
IGBT short	Arm short-U Arm short-V Arm Short-W Arm Short-DB	Inverter turns off its output if IGBT Arm or output shorts occur.
Encoder error	Encoder Err	This is displayed if there is a problem of encoder signal.
BX Protection (Instant cut off)	BX	Used for the emergency stop of the inverter. The inverter instantly turns off the output when the BX terminal is turned ON, and returns to regular operation when the BX terminal is turned OFF. Take caution when using this function.
Motor over speed	Over Speed	The motor runs exceeding 120% of its maximum default speed.
Communication error	COM Error CPU Error	This is displayed if there is any types of communication errors between the inverter main and loader.

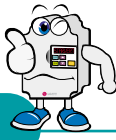

Basic configuration

Proper peripheral devices must be selected and correct connections made to ensure proper operation. An incorrectly applied or installed inverter can result in system malfunction or reduction in product life as well as component damage. You must read and understand this manual thoroughly before proceeding.



AC source supply
Use the power supply within the permissible range of inverter input power rating.

MCCB or Earth leakage circuit breaker (ELB)

Select circuit breakers with care. A large inrush current may flow in the inverter at power on.

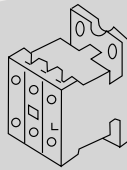
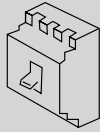

Magnetic contactor
Install it if necessary. Installed, do not use it for the purpose of starting or stopping. Otherwise, it could lead to reduction in product life.

AC reactor

The AC reactor must be used when the power factor is to be improved or the inverter is installed near a large power supply system (1000kVA or more and wiring distance within 10m).

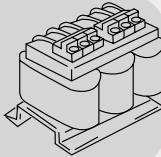

Installation and wiring

To operate the inverter with high performance for a long time, install the inverter in a proper place in the correct direction and with proper clearances. Incorrect terminal wiring could result in the equipment damage.

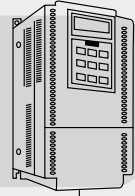

Ground

DC reactor

It is required for inverters 5.5kW~22kW (200/400V). Not necessary for inverters below 3.7kW.

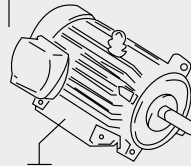
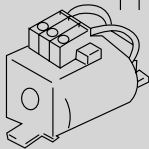

To motor
Do not connect a power factor capacitor, surge suppressor or radio noise filter to the output side of the inverter.

Ground

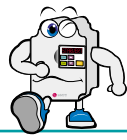

MEMO

A large, empty rectangular area with rounded corners, intended for writing a memo.



Safety Instructions

- For your safety, please read user's manual thoroughly before operating.
- Contact the nearest authorized service facility for examination, repair, or adjustment.
- Please contact qualified service technician when you need maintenance. Do not disassemble or repair by yourself!
- Any maintenance and inspection shall be performed by the personnel having expertise concerned.

© 2004.6 LS Industrial Systems Co.,Ltd. All rights reserved.

LS Industrial Systems Co., Ltd.

www.lgis.com

■ **HEAD OFFICE**

LS Tower 1026-6, Hogue-dong, Dongan-gu,
Anyang-si, Gyeonggi-do 431-848, Korea

- **Europe** +82-2-2034-4376 / ywsohn@lsgis.biz
- **Middle East** +82-2-2034-4901 / bonseongk@lsgis.biz
- **South West Asia** +82-2-2034-4645 / sungkyup@lsgis.biz
- **South East Asia** +82-2-2034-4707 / ohpark@lsgis.biz
- **CIS** +82-2-2034-4913 / jinhkang@lsgis.biz
- **America** +82-2-2034-4377 / yoonsupl@lsgis.biz



Specifications in this catalog are subject to change without notice due to continuous product development and improvement.

■ **Global Network**

- **LS Industrial Systems (Middle East) FZE** >> **Dubai, U.A.E.**
Address: LOB 19 JAFZA VIEW TOWER Room 205, Jebel Ali Freezone P.O. Box 114216, Dubai, United Arab Emirates
Tel: 971-4-886 5360 Fax: 971-4-886-5361 e-mail: hwyim@lsgis.biz
- **Dalian LS Industrial Systems Co., Ltd.** >> **Dalian, China**
Address: No.15, Liaohexi 3-Road, Economic and Technical Development zone, Dalian 116600, China
Tel: 86-411-8273-7777 Fax: 86-411-8730-7560 e-mail: lixk@lsgis.com.cn
- **LS Industrial Systems (Wuxi) Co., Ltd.** >> **Wuxi, China**
Address: 102-A, National High & New Tech Industrial Development Area, Wuxi, Jiangsu, 214028, P.R.China
Tel: 86-510-8534-6666 Fax: 86-510-522-4078 e-mail: xuhg@lsgis.com.cn
- **LS-VINA Industrial Systems Co., Ltd.** >> **Hanoi, Vietnam**
Address: Nguyen Khe - Dong Anh - Ha Noi - Viet Nam
Tel: 84-4-882-0222 Fax: 84-4-882-0220 e-mail: srjo@lsgisvina.com
- **LS-VINA Industrial Systems Co., Ltd.** >> **Hochiminh, Vietnam**
Address: 41 Nguyen Thi Minh Khai Str. Yoco Bldg 4th Floor, Hochiminh City, Vietnam
Tel: 84-8-3822-7941 Fax: 84-8-3822-7942 e-mail: sbpark@lsgisvina.com
- **LS Industrial Systems Tokyo Office** >> **Tokyo, Japan**
Address: 16FL, Higashi-Kan, Akasaka Twin Tower 17-22, 2-chome, Akasaka, Minato-ku Tokyo 107-8470, Japan
Tel: 81-3-3582-9128 Fax: 81-3-3582-2667 e-mail: jschuna@lsgis.biz
- **LS Industrial Systems Shanghai Office** >> **Shanghai, China**
Address: Room E-G, 12th Floor Huamin Empire Plaza, No.726, West Yan'an Road Shanghai 200050, P.R. China
Tel: 86-21-5237-9977 (609) Fax: 89-21-5237-7191 e-mail: jinhk@lsgis.com.cn
- **LS Industrial Systems Beijing Office** >> **Beijing, China**
Address: B-Tower 17FL Beijing Global Trade Center B/D. No.36, BeiSanHuanDong-Lu, DongCheng-District, Beijing 100013, P.R. China
Tel: 86-10-5825-6025,7 Fax: 86-10-5825-6026 e-mail: cuixiaorong@lsgis.com.cn
- **LS Industrial Systems Guangzhou Office** >> **Guangzhou, China**
Address: Room 1403,14F, New Poly Tower, 2 Zhongshan Liu Road Guangzhou, P.R. China
Tel: 86-20-8326-6764 Fax: 86-20-8326-6287 e-mail: linsz@lsgis.biz
- **LS Industrial Systems Chengdu Office** >> **Chengdu, China**
Address: 12Floor, Guodong Building, No52 Jindun Road Chengdu, 610041, P.R. China
Tel: 86-28-8612-9151 Fax: 86-28-8612-9236 e-mail: yangcf@lsgis.com.cn
- **LS Industrial Systems Qingdao Office** >> **Qingdao, China**
Address: 7B40, Haixin Guangchang Shenye Building B, No.9, Shandong Road Qingdao 26600, P.R. China
Tel: 86-532-8501-6568 Fax: 86-532-583-3793 e-mail: lirj@lsgis.com.cn