

ROLLON[®]

Linear Evolution

Light Rail

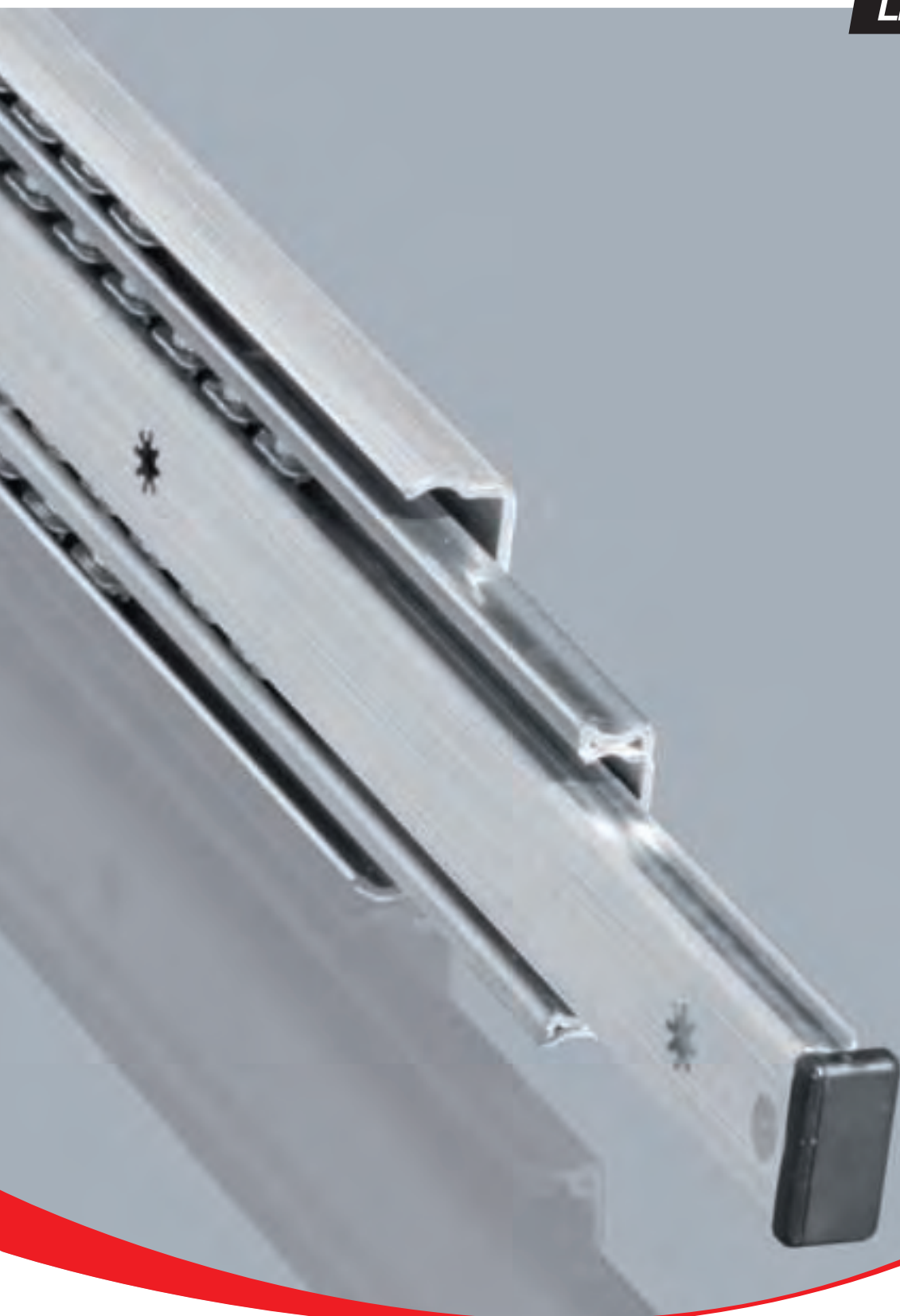

Product explanation



> Light telescopic rails, with full or partial extension



Fig. 1

The Light Rail product family consists of five series with full and partial extensions in a lightweight design. It is ideal for applications in which the mass of the rail is just as important as the bending rigidity.

The most important characteristics:

- Light and quiet running with heavy loads
- Long service life without maintenance
- Effective self-cleaning of the ball track
- High functional reliability
- Structural elasticity capable of absorbing minor impacts and absence of permanent deformation
- Not sensitive to side impacts

Preferred areas of application:

- Beverage industry
- Automotive
- Construction and machine technology (e.g., housing)
- Packaging machines
- Railcars (e. g., maintenance and battery extensions)
- Special machines

LPS 38

Partial extension with rails made of hot-dipped galvanized steel and plastic ball cages.



Fig. 2

LFS 46

Detachable internal rail which can be released with a latch. Rails are made of bright chrome-plated steel, the ball cages of steel and plastic. Roll back protection in closed position.



Fig. 3

LFS 57

Full extension with rails made of hot-dipped galvanized steel and zinc-plated steel ball cages. Roll back protection in closed position.



Fig. 4

LFS 58 SC

Full extension with automatic retraction and damping. The automatic retraction system is assisted by a spring-loaded mechanism that allows the rail to get back to a complete retraction before reaching the closed position.



Fig. 5

LFS 70

Full extension with rails made of zinc-plated galvanized and blue passivated steel. The ball cages are made of zinc-plated steel. Heavy load end stop in opened and closed position. Roll back protection in closed position.



Fig. 6

LFX 27

The stainless steel full extension consists of two inner guide rails that, connected to a double-T profile, form the intermediate element and two outer rails that form the connection to the connecting construction as fixed and moving element. The square cross-section allows a compact design of high load ratings and low deflection.



Fig. 7

DRX-DRS

Roller type telescopic rail made of stainless or galvanized steel. Corrosion resistant even if scratched, exposed to solvents or to shocks.



Fig. 8

Technical data

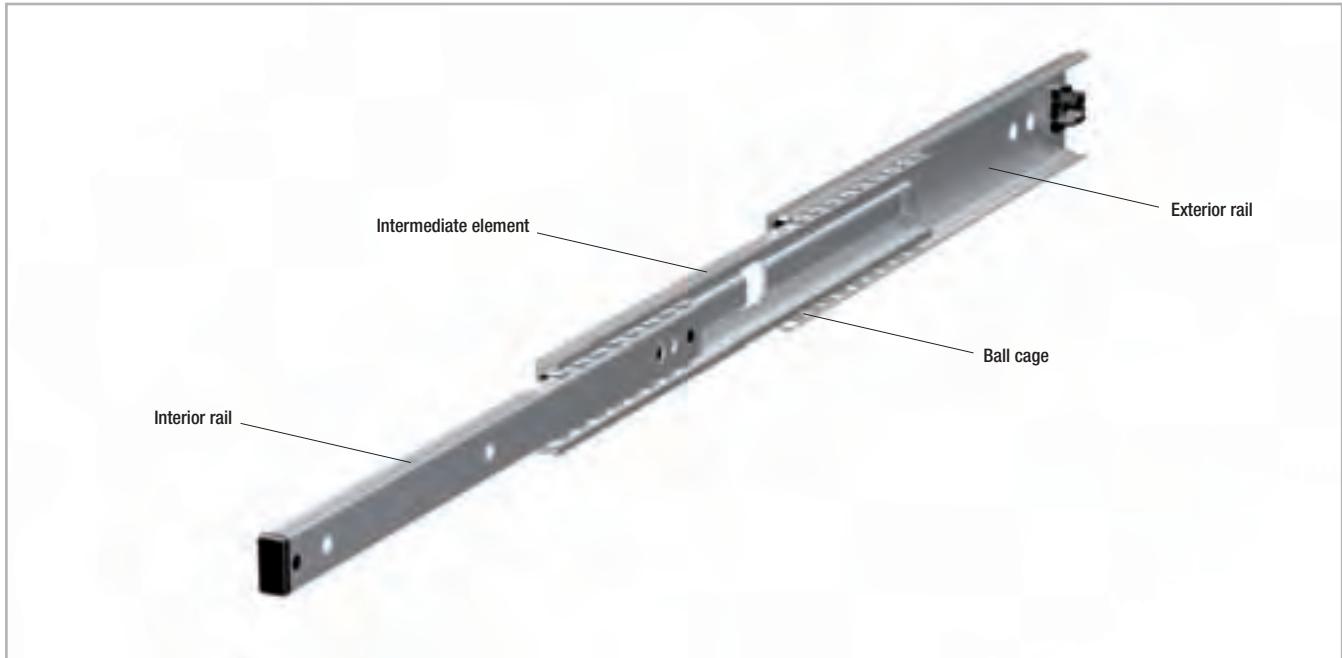

Fig. 9

Performance characteristics:

- Extension speed (depending on application):
 - Extension distance 100 - 500 mm: max. 0.5 m/s (19.69 in/s)
 - Extension distance 600 mm: max. 0.4 m/s (15.75 in/s)
 - Extension distance 700 mm: max. 0.3 m/s (11.81 in/s)
- LFS 58 SC series with automatic retraction
- Temperature range: from +10 °C to +40 °C, for DRX/DRS
 - From -30° to + 100° C
 - Temporary storage and transport temperature:
 - 20 °C to max. +80 °C (-4 °F to +176 °F)
- All systems are lubricated for life
- LFS/LPS rail material: hot galvanized or chromed steel
- LFS/LPS ball bearing cage material: galvanized steel or plastic
- LFS/LPS ball bearing material: hardened carbon steel
- DRX rail material: stainless steel AISI 316L
- DRS rail material: galvanized steel ISO 2081 compliant

Remarks:

- Assembly in cross-sectional width, here a positive tolerance of +0.5 mm is recommended (mounted under tension). If the extensions are installed with too small a tolerance, the service life is decreased
- Load capacity is per single rail (not per pair)
- Cycle data applies to the use of an extension pair (recommended)
- Vertical use of extensions (radial load) is recommended
- If mounted in a horizontal position, the load capacity will be reduced (see p. LR-12)
- Cathodic edge protection, additional corrosion protection with powder coating on request
- Roll back protection in closed position is friction locked (except LPS 38)
- Not suitable for moments – must be used as extension pair

Dimensions and load capacity

> LPS 38

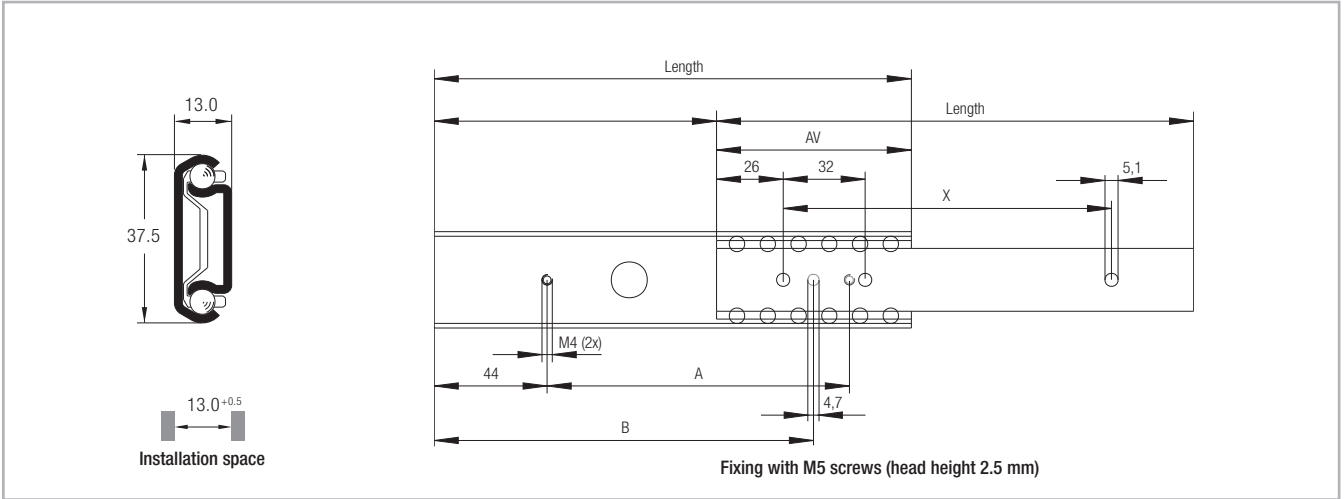

All dimensions given in mm

Fig. 10

Type	Size	Length [mm]	Extension loss AV [mm]	Stroke* [mm]	A [mm]	B [mm]	X [mm]	Load capacity**		Weight** [kg]
								C_{0rad} [N]	C_{0ax} [N]	
LPS	38	242	88	154	166	202	192	175	50	0.30
		317		229	241	277	256			0.40
		398	100	298	322	358	352			0.50
		473		373	397	433	416			0.60

* The stroke is the difference of the length, minus the extension loss AV

** The given load capacities and weights apply for a single extension

Tab. 1

Note: The given load capacities are guidelines with 100,000 cycles and uniform load distribution (area load) when using all mounting holes. The load values must be reduced in unfavorable conditions.

> LFS 46

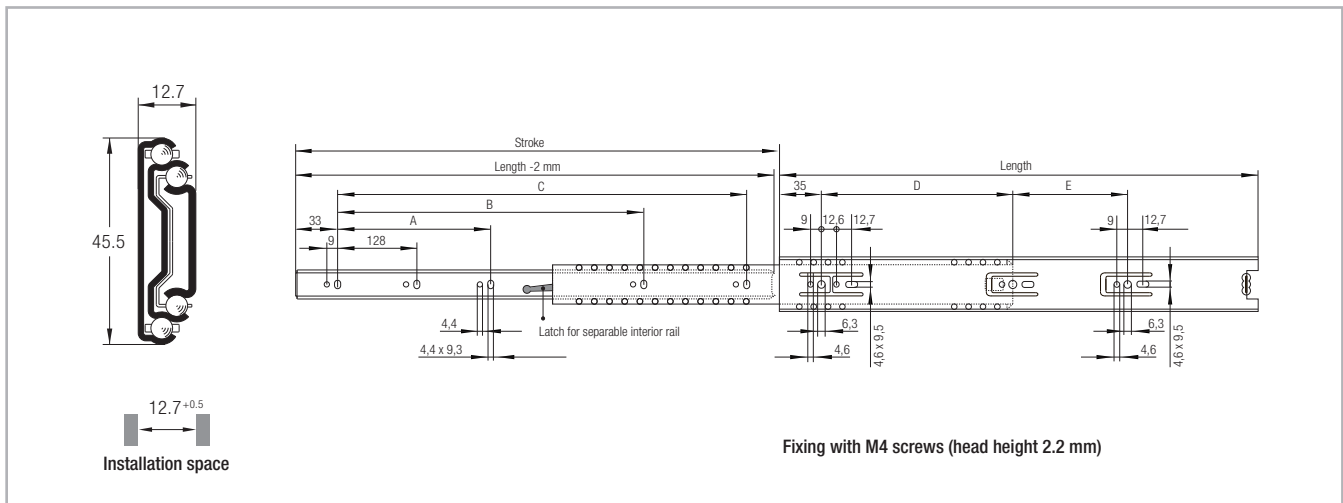

All dimensions given in mm

Fig. 11

Type	Size	Length	Stroke	A	B	C	D	E	Load capacity*	Load capacity*	Weight*
		[mm]	[mm]	[mm]	[mm]	[mm]	[mm]	[mm]	C_{0rad} [N]	C_{0ax} [N]	
LFS	46	300	305	-	-	242	192	-	150	50	0.48
		400	406	-	256	342	160	96	175		0.64
		450	457	-		392		160			0.71
		500	508	-	352	442	224	128	200		0.79
		550	559	224	416	492		192			0.88
		600	610		542	224	0.95				

* The given load capacities and weights apply for a single extension

Tab. 2

Note: The given load capacities are guidelines with 50,000 cycles and uniform load distribution (area load) when using all mounting holes. The load values must be reduced in unfavorable conditions.

> LFS 57

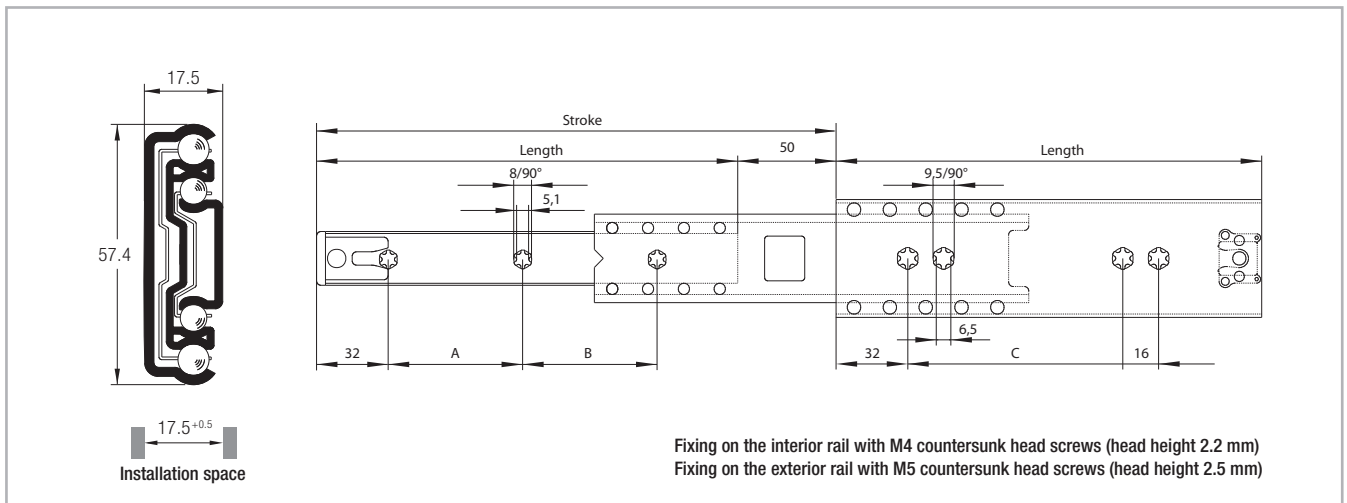

All dimensions given in mm

Fig. 12

Type	Size	Length	Stroke*	A	B	C	Load capacity**		Weight**
		[mm]	[mm]	[mm]	[mm]	[mm]	C_{0rad} [N]	C_{0ax} [N]	
LFS	57	300	350	128	104	160	250	80	0.84
		350	400		152				0.98
		400	450	160	168	256	325	80	1.13
		450	500		224				1.27
		500	550	224	208	384	375	80	1.42
		550	600		256				1.57
		600	650	288	240	384	400	80	1.71
		650	700		288				1.86
		700	750	320	312	384	400	80	2.01
		750	800		360				2.16

* The stroke is the sum of the length, and the over extension

** The given load capacities and weights apply for a single extension

Tab. 3

Note: The given load capacities are guidelines with 100,000 cycles and uniform load distribution (area load) when using all mounting holes. The load values must be reduced in unfavorable conditions.

> LFS 58 SC

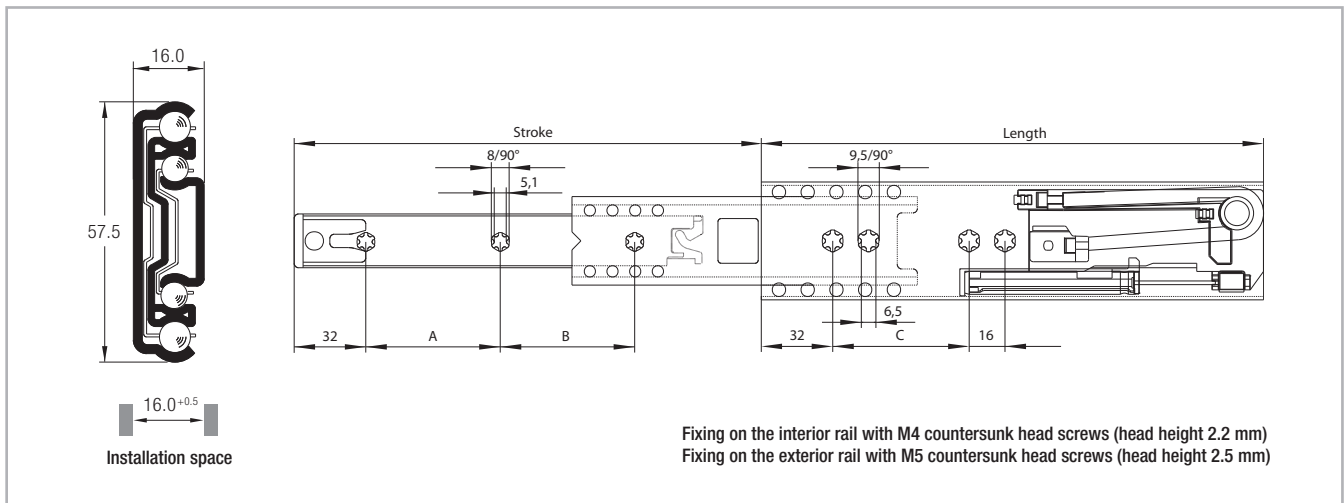

All dimensions given in mm

Fig. 13

Type	Size	Length [mm]	Stroke [mm]	A [mm]	B [mm]	C [mm]	Load capacity* C _{0rad} [N]	Weight* [kg]
LFS	58	400	434	128	128	224	200	1.10
		450	484	160	160	256	250	1.25
		500	534				275	1.40
		550	584	192	320	300	1.55	

* The given load capacities and weights apply for a single extension

Tab. 4

Note: The given load capacities are guidelines with 100,000 cycles and uniform load distribution (area load) when using all mounting holes. The load values must be reduced in unfavorable conditions. Horizontal installation is not possible due to the damping system. The damping effect is reduced for loads of 450 N and higher per extension pair.

> LFS 70

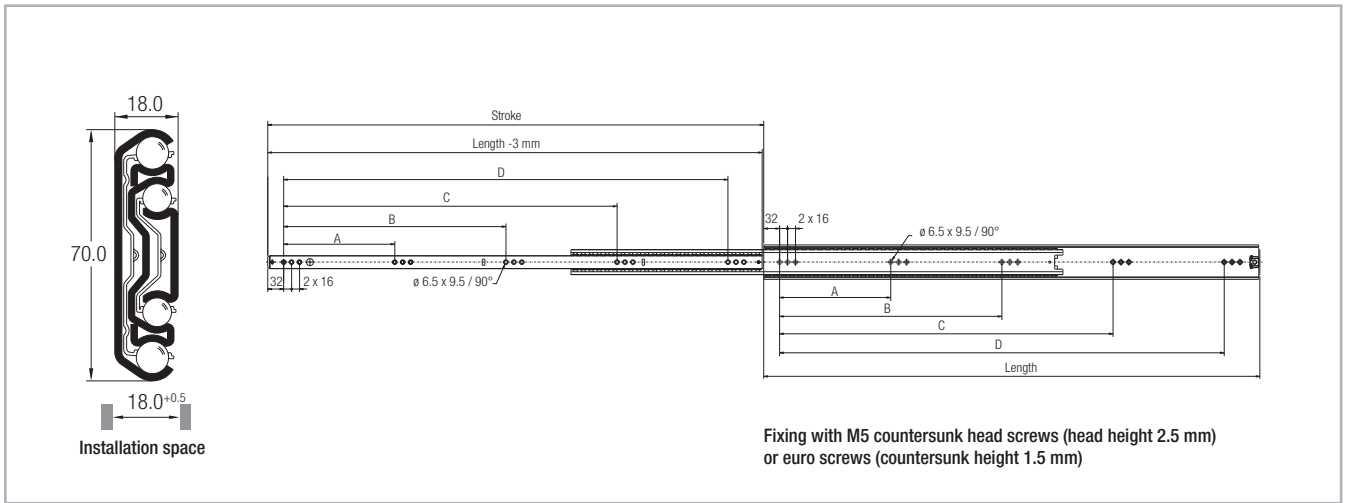

All dimensions given in mm

Fig. 14

Type	Size	Length	Stroke	A	B	C	D	Load capacity*		Weight*	
		[mm]	[mm]	[mm]	[mm]	[mm]	[mm]	C_{Orad} [N]	C_{Oax} [N]		
LFS	70	400	400	-	-	-	288	525	900**	150	1,55
		450	450	-	-	160	320	575	950**		1,74
		500	500	-	-	192	384	650	975**		1,94
		550	550	-	-	224	448		1000**		2,13
		600	600	-	-				975**		2,32
		700	700	-	192	384	576	875**	2,70		
		800	800	-	224	448	672	600	725**		3,10
		1100	1100	224	448	672	896	450	525**		100

* The given load capacities and weights apply for a single extension
 ** 10.000 cycles

Tab. 5

Note: The given load capacities are guidelines with 10.000 cycles and uniform load distribution (area load) when using all mounting holes. The load values must be reduced in unfavorable conditions.

> LFX 27

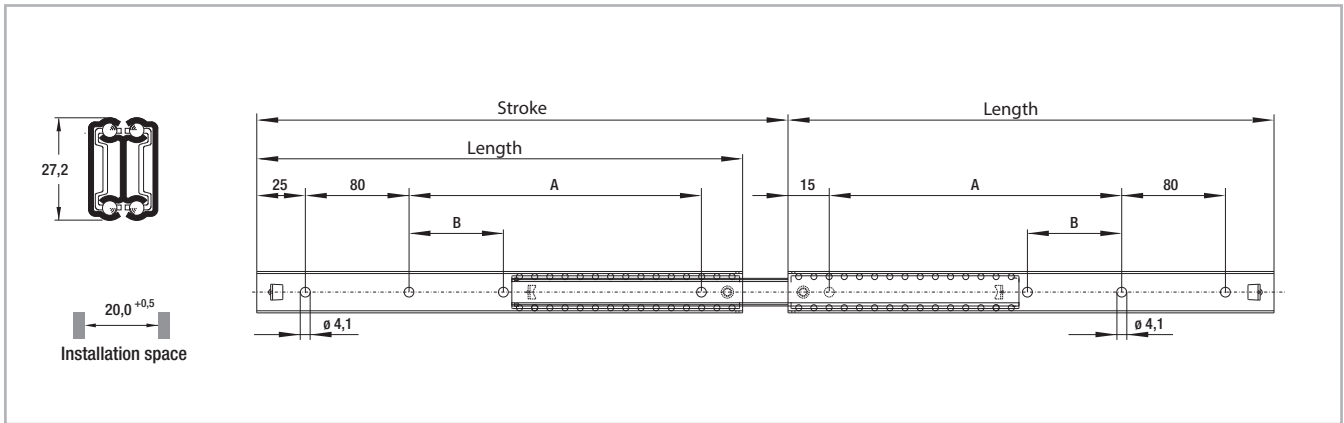

Fig. 15

Type	Size	Length [mm]	Stroke [mm]	A [mm]	B [mm]	Load capacity* [N]				Weight* [kg]
						to 10.000 cycles		to 100.000 cycles		
						C_{0rad}	C_{0ax}	C_{0rad}	C_{0ax}	
LFX	27	300	326	180	-	175	25	125	25	0,43
		350	376	230	70					0,49
		400	426	280	100					0,57
		450	476	330	100					0,64
		500	526	380	140					0,72
		550	576	430	160					0,82

* The given load capacities and weights apply for a single extension

Tab. 6

> DRX/DRS

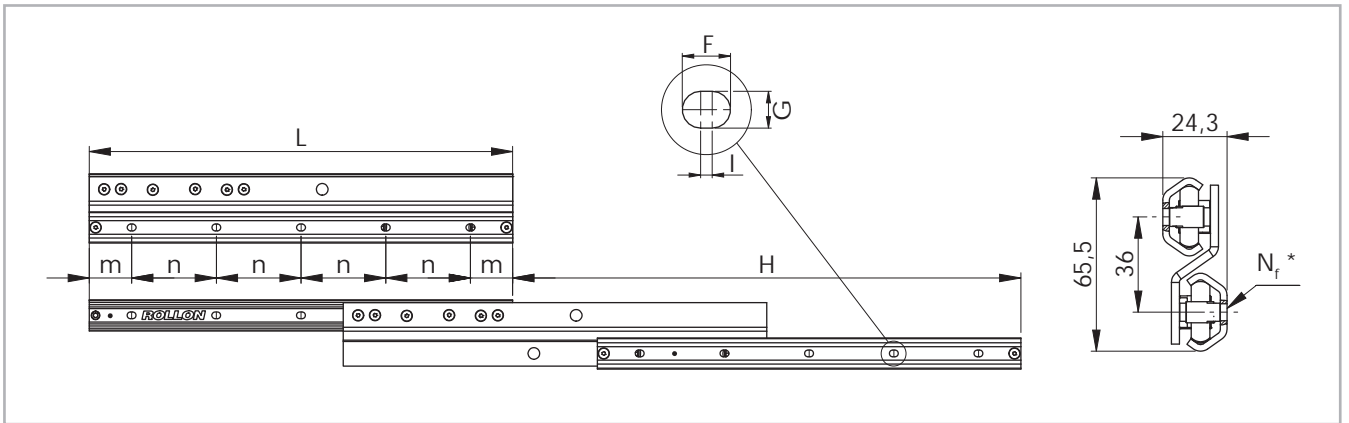

Fig. 16

* Number of mounting holes

Type	Size	Length L [mm]	Stroke H [mm]	Load capacity* C_{0rad} [N]	Fixed and movable rail							
					m [mm]	n [mm]	N_f [2 rails]	Holes for screws	Weight [kg/m]	F [mm]	G [mm]	I [mm]
DRX DRS	30	400	480	150	40	80	10	M5	3.40	8,4	6,4	2
		480	560	200			12					
		560	640	240			14					
		640	720	280			16					
		720	800	320			18					
		800	880	360			20					
		880	960	350			22					
		960	1040	310			24					
		1040	1120	250			26					

* The given load capacities and weights apply for a single extension

Tab. 7

Technical instructions



> Load capacities

Vertical installation (radial load)

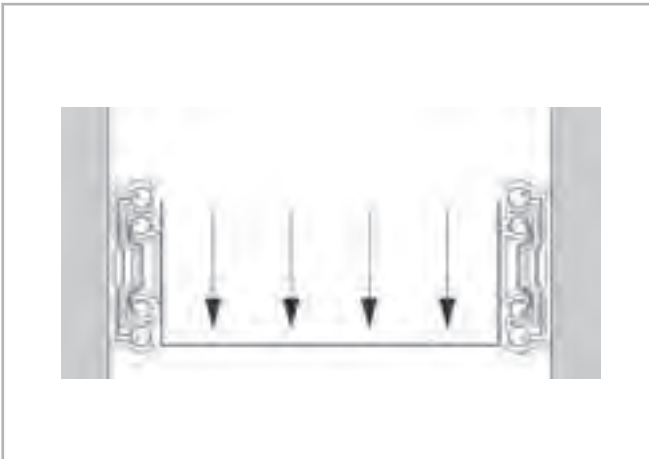

Fig. 17

The given loading capacities are guidelines for an extension rail vertically mounted with uniform load distribution using all mounting holes. The load values must be reduced in unfavorable conditions.

Horizontal installation (axial load)

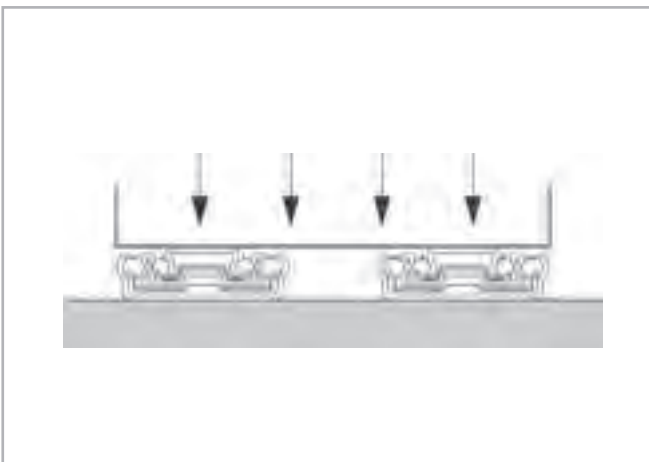

Fig. 18

For horizontal mounted extensions the load capacity is reduced (see pg. LR-5ff). The DRS/DRX series is not suitable for use on horizontal mounting (axial loads)

> Speed

The extension speed is determined by the size of the intermediate elements. Therefore, the maximum extension speed is inversely proportional to the overall extension of the rails (see fig. 19). The maximum extension speed is also directly related to the applied load and operating time. The indicated data refers to continuous operation at the maximum load capacity.

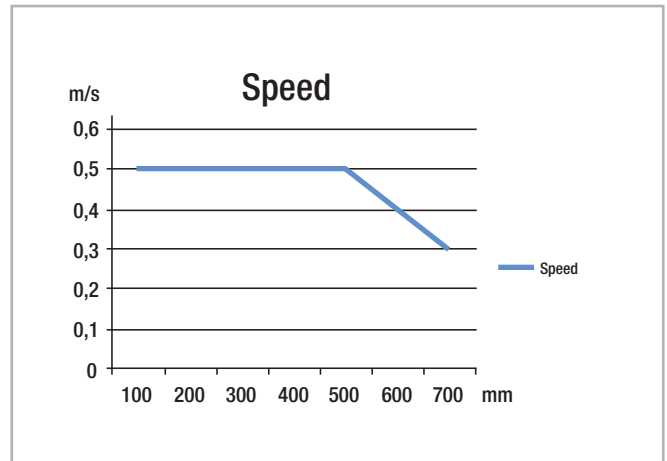

Fig. 19

> Temperature

Continual operating temperature of the Light Rail extensions is +10 °C to +40 °C. Temporary storage and transport temperature: -20 °C to max. +80 °C. The operating temperature for the DRX/DRS rails ranges from - 30 °C to + 100 °C. For more information please contact the Rollon Application engineering department.

> Lubrication

All extensions of the Light Rail product family are lubricated for life. Different lubricants for special applications are available upon request. Example: Lubricant with FDA approval for use in the food industry. For more information please contact the Rollon Application engineering department.

> Corrosion protection

Base material for the Light Rail product family is cold-rolled, hot-dipped galvanized steel. The cathodic edge protection offers a perfect combination of quality and cost-efficiency. The surface protection conforms to RoHS. The DRX/DRS series rails are also available in the stainless steel version for a high corrosion resistance. For more information please contact the Rollon Application engineering department.

> Installation instructions

- The existing internal stops are not designed to stop the moving load. They are only supposed to retain the ball-cage and prevent the internal parts to slide out of the assembly. An external end-stop must always be installed to stop the moving load.
- To achieve optimum running properties, high service life and rigidity, it is necessary to fix the Light Rail extensions with all accessible holes on a rigid and level surface. When using an extension pair, please observe the parallelism of the installation surfaces. The fixed and movable rails will assume the rigidity of the mounting structure.

- Light Rail full and partial extensions are suitable for use in automatic systems. For this, the stroke should remain constant in all moving cycles and the extension speed must be checked (see pg. LR-13, fig.19). The movement of the extensions is enabled by internal ball cages, which could experience an offset from the original position with differing strokes. This phase offset can have a negative effect on the running properties or limit the stroke. If differing strokes occur in an application, the drive force must be sufficiently dimensioned in order to appropriately synchronize the ball cage offset. As an alternative, an extra full stroke cycle can be performed every certain number of cycles, in order to re-phase the ball cage in its correct position.

Horizontally installed guides

Horizontally installed extensions can support tension or compression loads (see figs. 20 and 21).

For the horizontal mounting of extensions with compression loads, please take the following conditions into account: The Hertzian stress of the balls in no longer effective due to the expansion of the rail profile; the nominal tension tolerance of +0.5 mm is eliminated due to the installation confi-

guration. Both the above mentioned conditions contribute to a significant reduction of the axial load capacity.

Horizontally-mounted rails (axial load) also determine a considerably higher deflection of the extended tips if compared to traditionally vertically-mounted rails (radial load).

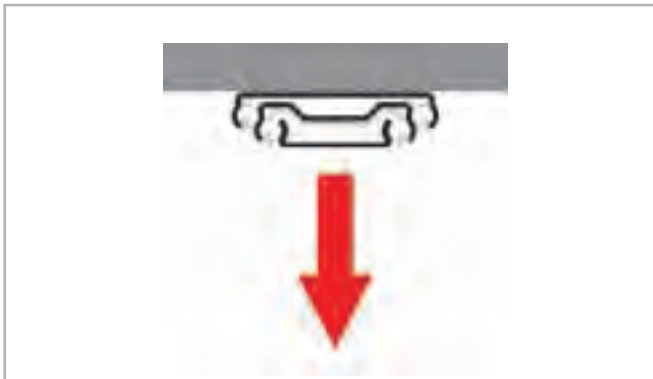

Fig. 20

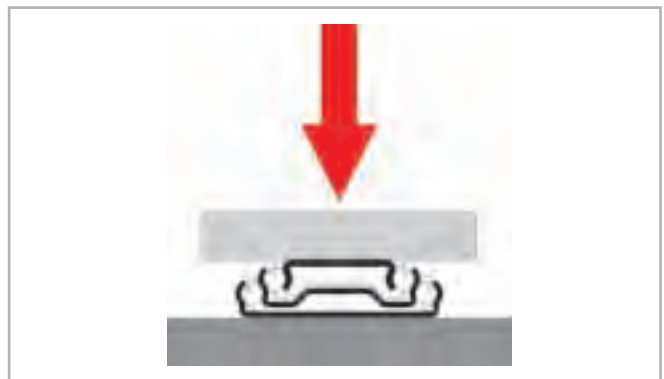

Fig. 21

> DRX/DRS installation

- During installation care must be taken that the movable elements are assembled as in the figure; i.e. as the lower rail. The opposite upside-down assembly negatively affects the function.
- Internal stops are used to stop the unloaded slider and the ball cage. Please use external stops as end stops for a loaded system.
- To achieve optimum running properties, high service life and rigidity, it is necessary to fix the telescopic rails with all accessible holes on a rigid and level surface.
- When using two telescopic rails, please observe the parallelism of the installation surfaces. The fixed and movable rails fit to the rigid assembly construction.

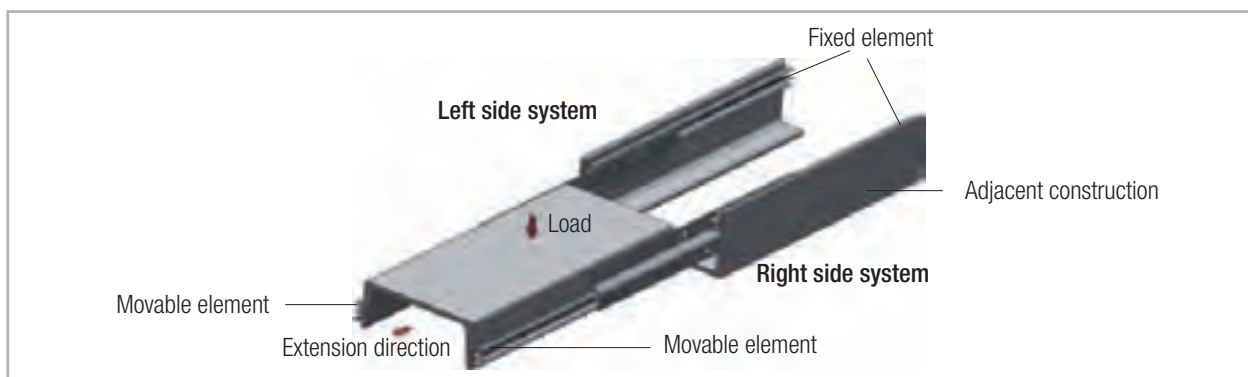

Fig. 22

Ordering key

> Light Rail

LFS	58-	400	SC	
			Automatic retraction only in LFS 58 SC	see pg. LR-8
		Rail length in mm		see pg. LR-5
	Size			see pg. LR-5
Rail type				see pg. LR-5

Ordering example: LFS58-0400SC

Notes on ordering: The rail lengths are always indicated as 4 digits with 0 prefixes