

ROLLON[®]

Linear Evolution

Mono Rail

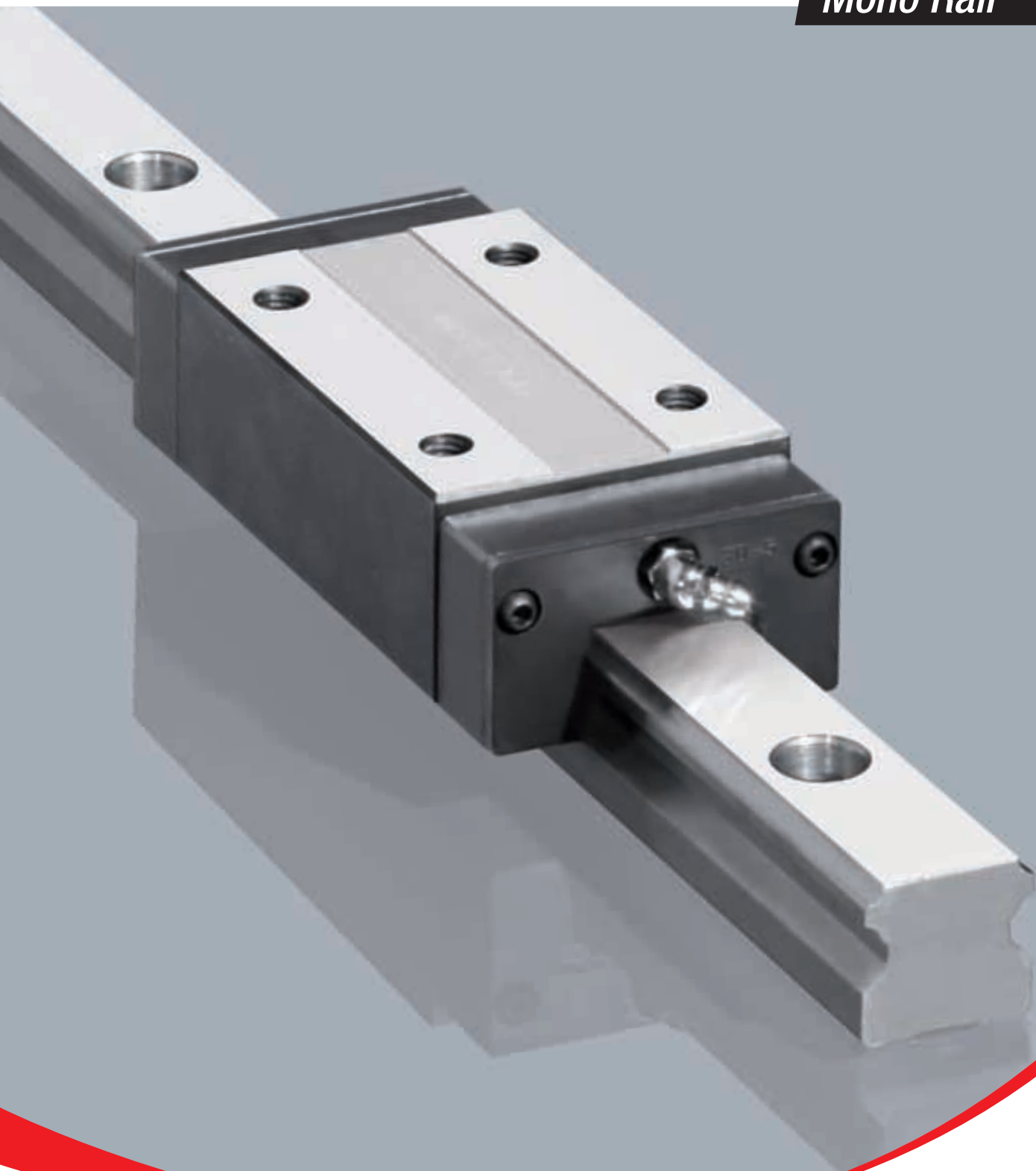

Product explanation



> Mono Rails are profile rails for the highest degree of precision



Fig. 1

The running grooves are ground in semicircular profile and have a contact angle of 45° in X-arrangement so that the same load capacity is guaranteed in all principle directions. Use of large steel balls enables high load and moment capacities. All carriages in size 55 are equipped with ball chains.

The most important characteristics:

- X-arrangement with 2-point contact of the raceways
- Uniform loading capacity in all main directions
- High ability for self-regulating
- Small differential slip in comparison to 4-point contact
- Very quiet running and low operating noise
- Low maintenance due to advanced lubrication chamber
- Small displacement force in preload compared to 4-point contact
- Mono Rail profile rails meet the market standard and can replace linear rails of the same design from other manufacturers while maintaining the main dimensions
- Miniature Mono Rails available in a standard or large version
- Miniature Mono Rail available in Martensite stainless steel.

Preferred areas of application:

- Construction and machine technology (safety doors, feeding)
- Packaging machines
- Special purpose machinery
- Logistics (e.g., handling units)
- Medical technology (e.g., X-ray equipment, hospital gurneys)
- Semiconductors and electronics industry

MRS / MRT

Standard carriage with flange in two different heights. MRT is the lower version.



Fig. 2

MRS...W / MRZ...W / MRT...W

Carriage without flange, also called block. Available in three different heights. MRT is the lower version; MRZ is the intermediate size.



Fig.3

MRS...L

Carriage in long version for holding larger loads. MRS...L is the version with flange.



Fig. 4

MRS...LW / MRT...LW

Carriage in long version without flange. Available in two different heights. MRT is the lower version.



Fig. 5

MRT...S

Carriage with flange in short version for lower loads with equally high precision.



Fig.6

MRT...SW

Carriage without flange in short version for lower loads with equally high precision.



Fig. 7

MRR...F

Guide rail MRR...F for bolting from below with threaded holes. Design with smooth surface without bevels.



Fig. 8

Standard width

Compact technology and high performance in its smallest structural shape.



Fig. 9

Large width

Wide miniature profile rails, with a compact size, allow the acceptance of higher forces and moments. Especially suited for single rail applications.



Fig. 10

Technical data

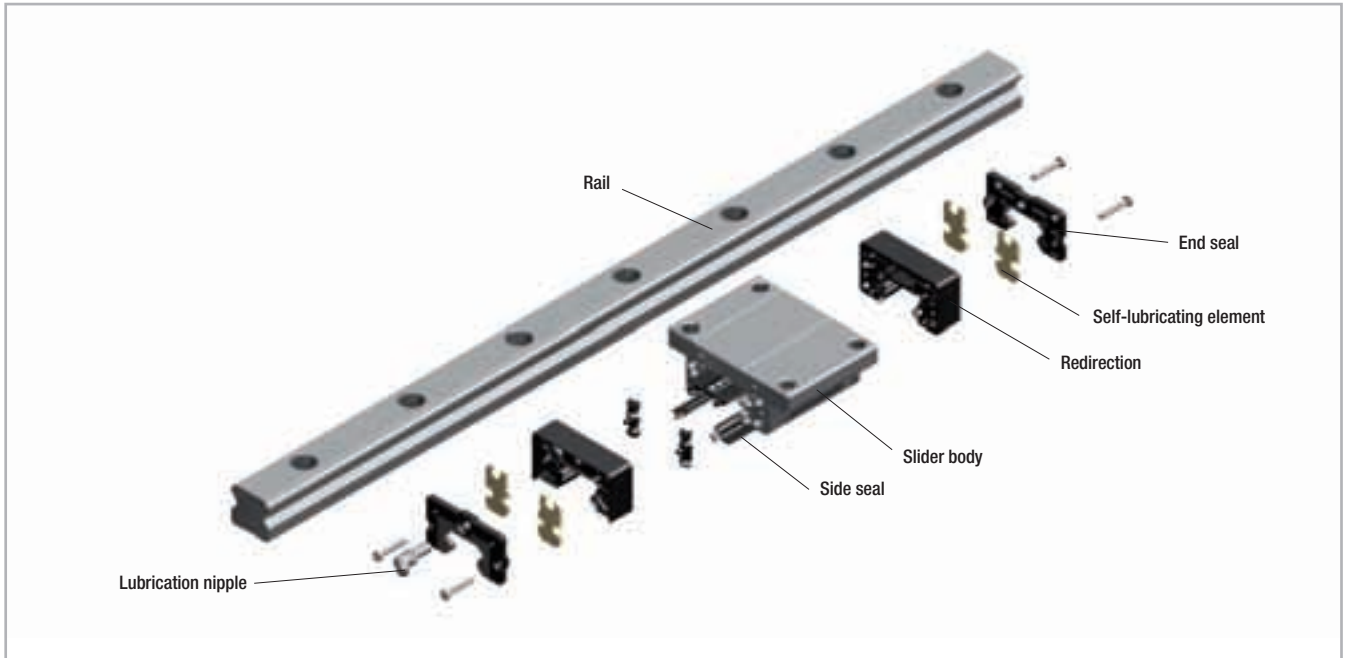

Fig. 11

Performance characteristics:

- Mono Rail available sections: 15, 20, 25, 30, 35, 45, 55
- Standard version Miniature Mono Rail available sections: 7, 9, 12, 15
- Large version Miniature Mono Rail available sections: 9, 12, 15
- Max. operating speed Mono Rail: 3.5 m/s (137.79 in/s) (depending on application)
- Max. operating speed Miniature Mono Rail: 3m/s (118,11 in/s)
- Max. operating temperature: +80 °C (+176 °F) (depending on application)
- Available rail lengths up to approx. 4,000 mm (157.5 in) for Mono Rail (see Ordering key, Table 31)
- Four preload classes for Mono Rail: G1, K0, K1, K2
- Three precision classes: N, H, P
- Three preload classes for the Miniature Mono Rails: V0, VS, V1
- Lengths for single rails are available up to 1,000mm (39.37 in) for the Miniature Mono Rail

Remarks:

- Combining rails is possible (joining)
- The fixing holes on the carriages with flange can also be used as through holes for fastening from below. Here, the reduction in size of the screw diameter must be observed
- Various surface coatings on request, e.g. black coating, hard chrome plating, nickel plating
- Manual and pneumatic clamping elements available as accessories. Depending on the height of the carriage, additional adapter plates must be used
- Dimensions H_2 and L of the carriage change when using metal deflectors and other seals. Refer to Sec. 4 Accessories, pg. MR-15f
- The carriages in size 55 are equipped with ball chains
- Primary lubricated systems have an increased displacement resistance

> Mono Rail load capacities

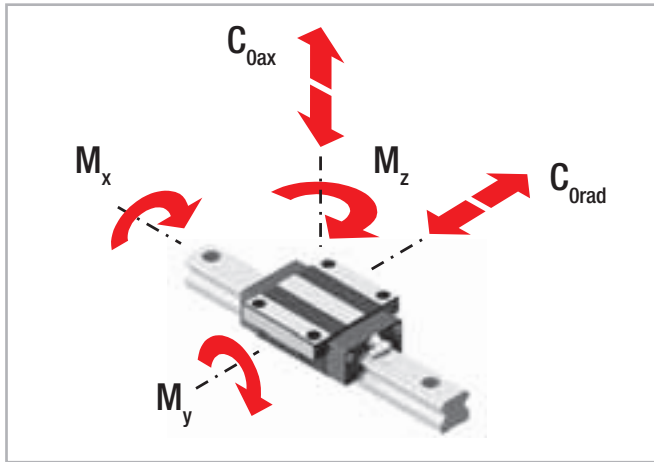

Fig. 12

Type	Load capacities [N]		Static moments [Nm]		
	dyn. C	stat. C _{0rad} stat. C _{0ax}	M _x	M _y	M _z
MRS15 MRS15W MRT15W	8500	13500	100	68	68
MRT15SW	5200	6800	51	18	18
MRS20 MRS20W MRT20W	14000	24000	240	146	146
MRT20SW	9500	14000	70	49	49
MRS20L MRS20LW	16500	30000	300	238	238
MRS25 MRS25W MRT25W MR25W	19500	32000	368	228	228
MRT25SW	12500	17500	175	69	69
MRS25L MRS25LW MRT25LW	26000	46000	529	455	455

Tab. 1

Type	Load capacities [N]		Static moments [Nm]		
	dyn. C	stat. C _{0rad} stat. C _{0ax}	M _x	M _y	M _z
MRS30 MRS30W MRT30W	28500	48000	672	432	432
MRT30SW	17500	24000	336	116	116
MRS30L MRS30LW MRT30LW	36000	64000	896	754	754
MRS35 MRS35W MRT35W	38500	62000	1054	620	620
MRT35SW	25000	36500	621	209	209
MRS35L MRS35LW MRT35LW	48000	83000	1411	1098	1098
MRS45 MRS45W MRT45W	65000	105000	2363	1378	1378
MRS45L MRS45LW MRT45LW	77000	130000	2925	2109	2109
MCS55 MCS55W MCT55W	123500	190000	4460	3550	3550
MCS55L MCS55LW MCT55LW	155000	249000	5800	6000	6000

Tab. 2

> Miniature Mono Rail load capacities

Standard width

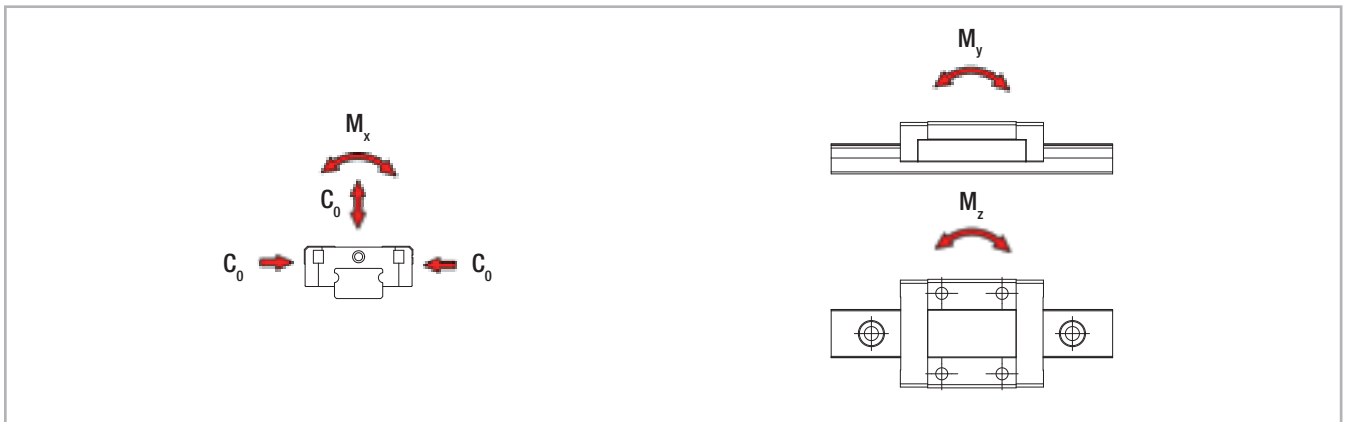

Fig. 13

Type	Load capacities [N]		Static moments [Nm]		
	dyn. C_{100}	stat. C_0	M_x	M_y	M_z
MR07MN	890	1400	5.2	3.3	3.3
MR09MN	1570	2495	11.7	6.4	6.4
MR12MN	2308	3465	21.5	12.9	12.9
MR15MN	3810	5590	43.6	27	27

Tab. 3

Large width

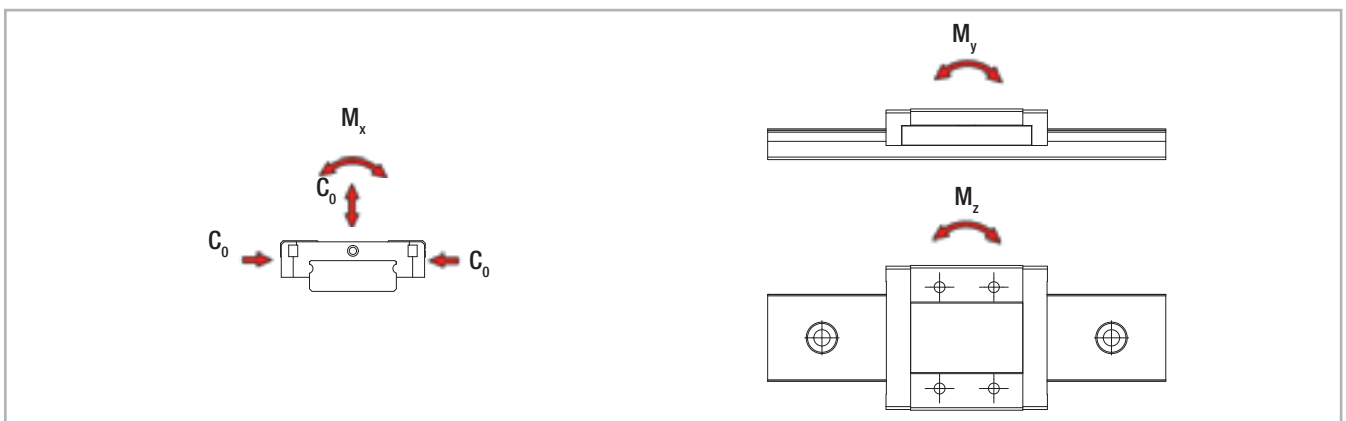

Fig. 14

Type	Load capacities [N]		Static moments [Nm]		
	dyn. C_{100}	stat. C_0	M_x	M_y	M_z
MR09WN	2030	3605	33.2	13.7	13.7
MR12WN	3065	5200	63.7	26.3	26.3
MR15WN	5065	8385	171.7	45.7	45.7

Tab. 4

Product dimensions



> MRS – carriage with flange

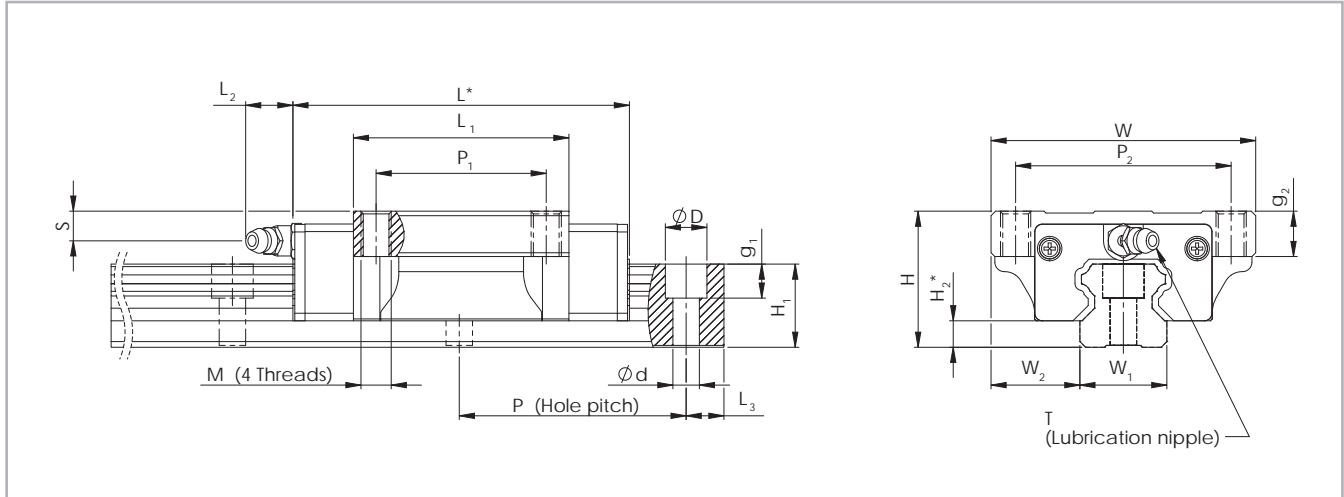

* Dimensions H2 and L change when using metal deflectors and other seals (see pg. MR-11, tab. 11)

Fig. 15

Type	System [mm]				Slider MRS [mm]									Weight [kg]	Rail MRR [mm]							Weight [kg/m]
	H	W	W ₂	H ₂	L	P ₂	P ₁	M	g ₂	L ₁	L ₂	T	S		W ₁	H ₁	P	d	D	g ₁	L ₃ *	
MRS15	24	47	16	4,6	69	38	30	M5	8	40	5	Ø3	4,3	15	14		4,5	7,5	5,8		1,4	
MRS20	30	63	21,5	5	81,2	53	40	M6	9	48,8			7	0,4	20	18	60	6	9,5	9		2,6
MRS20L					95,7					63,4												
MRS25	36	70	23,5	7	91	57	45	M8	12	57			7,8	0,57	23	22		7	11	9,5	20	3,6
MRS25L					113					79,1												
MRS30	42	90	31	9	114	72	52	M10	12	72			7	1,1	28	26						5,2
MRS30L					135,3					94,3												
MRS35	48	100	33	9,5	114	82	62	M10	13	80			8	1,6	34	29	80	9	14	12,5		7,2
MRS35L					139,6					105,8												
MRS45	60	120	37,5	14	142,5	100	80	M12	15	105			8,5	2,7	45	38	105	14	20	17,5	22,5	12,3
MRS45L					167					129,8												

* Only applies when using max. rail lengths (see Ordering key)

Tab. 5

Type	System [mm]				Slider MCS [mm]									Weight [kg]	Rail MCR [mm]							Weight [kg/m]
	H	W	W ₂	H ₂	L	P ₂	P ₁	M	g ₂	L ₁	L ₂	T	S		W ₁	H ₁	P	d	D	g ₁	L ₃ *	
MCS55	70	140	43,5	12,7	181,5	116	95	M14	21	131	12	M8 x 1	20	5,4	53	38	120	16	23	20	30	14,5
MCS55L					223,7					173												

* Only applies when using max. rail lengths (see Ordering key)

Tab. 6

> MRS – carriage without flange

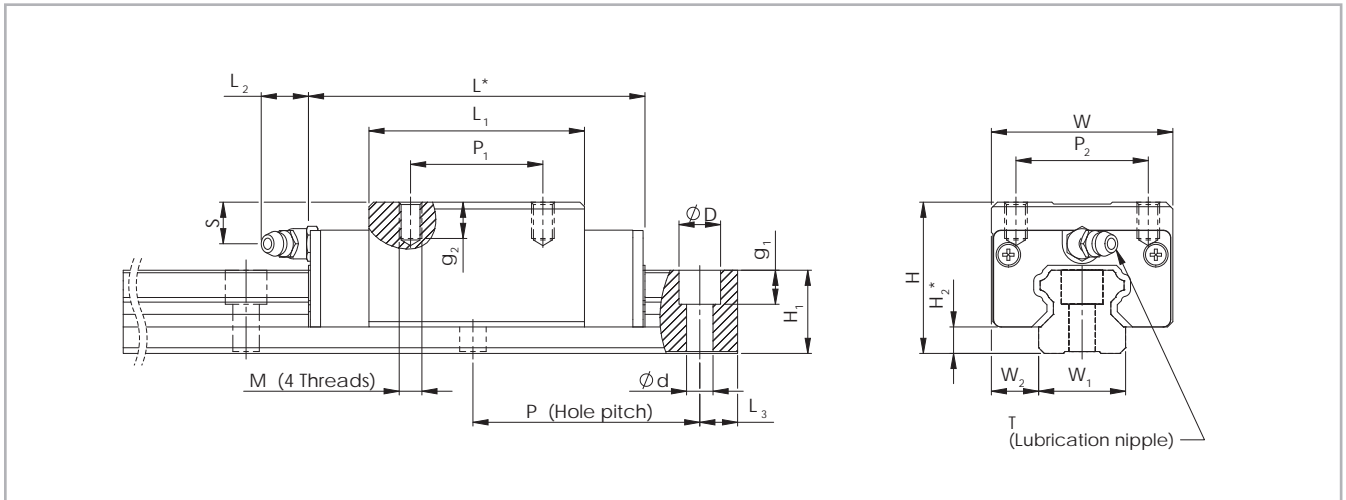

* Dimensions H2 and L change when using metal deflectors and other seals (see pg. MR-11, tab. 11)

Fig. 16

Type	System [mm]				Slider MRS [mm]									Weight [kg]	Rail MRR [mm]							Weight [kg/m]
	H	W	W ₂	H ₂	L	P ₂	P ₁	M	g ₂	L ₁	L ₂	T	S		W ₁	H ₁	P	d	D	g ₁	L ₃ *	
MRS15W	28	34	9.5	4,6	69	26	26	M4	6.4	40	5	Ø3	8,3	0.21	15	14		4.5	7.5	5.8		1.4
MRS20W	30	44	12	5	81.2	32	36	M5	8	48.8	12	M6 x 1	7	0.31	20	18	60	6	9.5	9	20	2.6
MRS20LW					95.7					50				63.4								0.47
MRS25W	40	48	12.5	7	91	35	35	M6	9.6	57	12	M6 x 1	11.8	0.45	23	22	80	7	11	9.5	20	3.6
MRS25LW					113					50				79.1								0.56
MRS30W	45	60	16	9	114	40	40	M8	12.8	72	17	M8 x 1	10	0.91	28	26	80	9	14	12.5	22.5	5.2
MRS30LW					135.3					60				94.3								1.2
MRS35W	55	70	18	9,5	114	50	50	M8	12.8	80	17	M8 x 1	15	1.5	34	29	80	9	14	12.5	22.5	7.2
MRS35LW					139.6					72				105.8								1.9
MRS45W	70	86	20.5	14	142.5	60	60	M10	16	105	17	M8 x 1	18.5	2.3	45	38	105	14	20	17.5	22.5	12.3
MRS45LW					167					80				129.8								2.8

* Only applies when using max. rail lengths (see Ordering key)

Tab. 7

Type	System [mm]				Slider MCS [mm]									Weight [kg]	Rail MCR [mm]							Weight [kg/m]
	H	W	W ₂	H ₂	L	P ₂	P ₁	M	g ₂	L ₁	L ₂	T	S		W ₁	H ₁	P	d	D	g ₁	L ₃ *	
MCS55W	80	100	23.5	12.7	181.5	75	75	M12	19	131	12	M8 x 1	30	5.2	53	38	120	16	23	20	30	14.5
MCS55LW					223.7					95				173								6.7

* Only applies when using max. rail lengths (see Ordering key)

Tab. 8

> MRT – carriage without flange

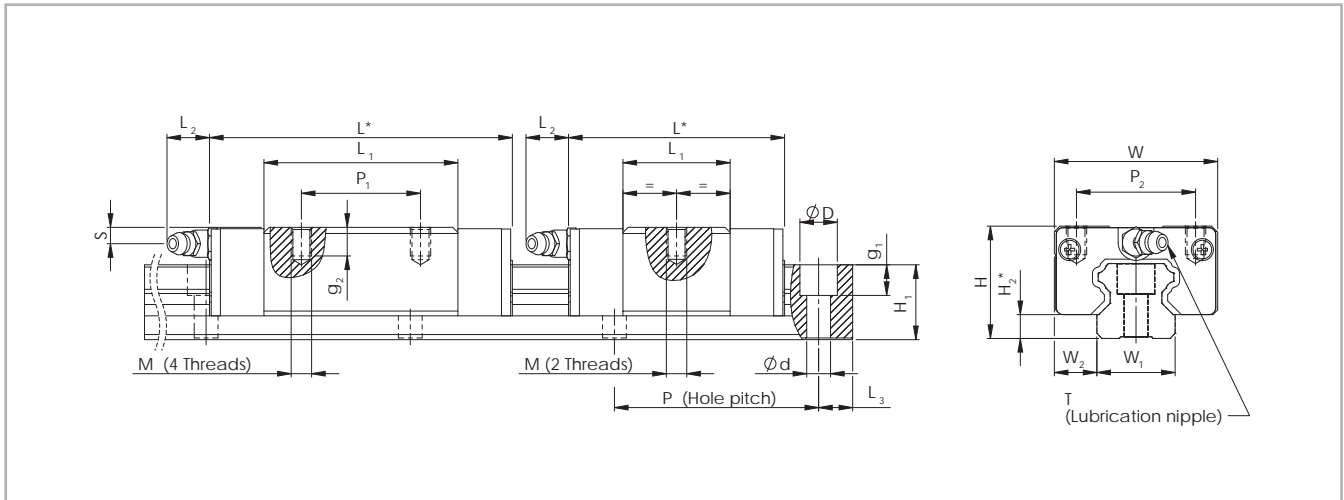

* Dimensions H₂ and L change when using metal deflectors and other seals (see pg. MR-11, tab. 11)

Fig. 17

Type	System [mm]				Slider MRT [mm]										Weight [kg]	Rail MRR [mm]							Weight [kg/m]
	H	W	W ₂	H ₂	L	P ₂	P ₁	M	g ₂	L ₁	L ₂	T	S	W ₁		H ₁	P	d	D	g ₁	L ₃ *		
MRT15W	24	34	9.5	4.6	69	26	26	M4	5.6	40	5	∅3	4.3	0.17	15	14		4.5	7.5	5.8		1.4	
MRT15SW					50.6		-			21.6				0.1									
MRT20W	28	42	11	5	81.2	32	32	M5	7	48.8			5	0.26	20	18	60	6	9.5	9		2.6	
MRT20SW					60.3		-			28				0.17									
MRT25W					91		35			57				0.38									
MRT25SW	33	48	12.5	7	65.5	35	-	M6	8.4	31.5			4.8	0.21	23	22		7	11	9.5		3.6	
MRT25LW					113		50			79.1				0.53							20		
MRT30W					114		40			72	12	M6 x 1		0.81									
MRT30SW	42	60	16	9	80	40	-			38.6			7	0.48	28	26						5.2	
MRT30LW					135.3		60	M8	11.2	94.3				1.06									
MRT35W					114		50			80				1.2				80	9	14	12.5		
MRT35SW	48	70	18	9.5	79.7	50	-			45.7			8	0.8	34	29						7.2	
MRT35LW					139.6		72			105.8				1.6									
MRT45W					142.5		60			105				2.1									
MRT45LW	60	86	20.5	14	167	60	80	M10	14	129.8	17	M8 x 1	8.5	2.6	45	38	105	14	20	17.5	22.5	12.3	

* Only applies when using max. rail lengths (see Ordering key)

Tab. 9

Type	System [mm]				Slider MCT [mm]										Weight [kg]	Rail MCR [mm]							Weight [kg/m]
	H	W	W ₂	H ₂	L	P ₂	P ₁	M	g ₂	L ₁	L ₂	T	S	W ₁		H ₁	P	d	D	g ₁	L ₃ *		
MCT55W	68	100	23.5	12.7	181.5	75	75	M12	15	131	13	M8 x 1	18	5	53	38	120	16	23	20	30	14.5	
MCT55LW					223.7		95			173				6.6									

* Only applies when using max. rail lengths (see Ordering key)

Tab. 10

> MRZ – carriage without flange

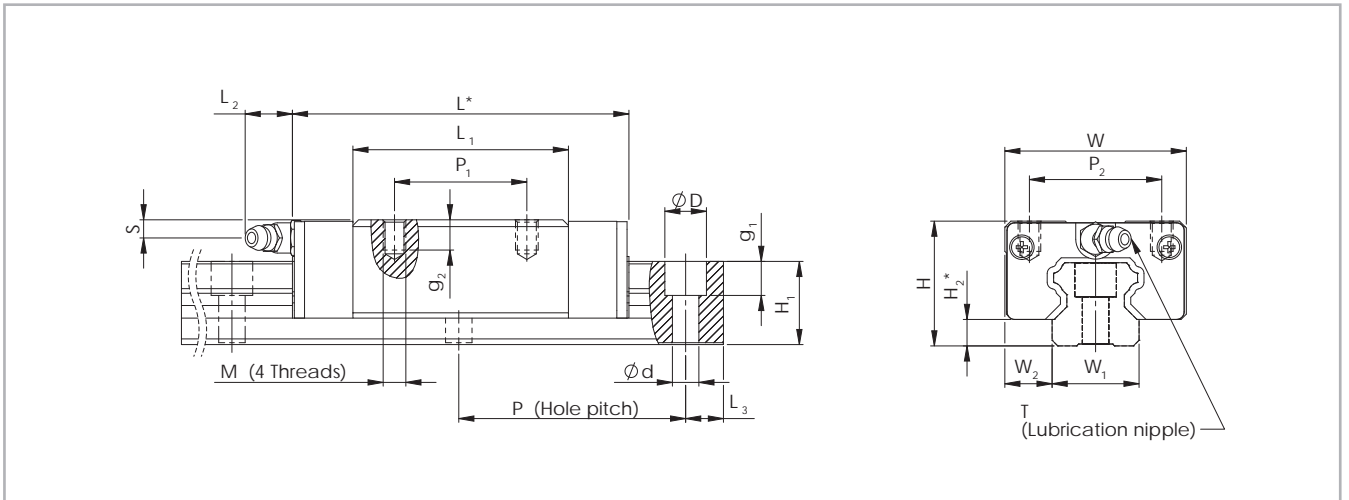

* Dimensions H2 and L change when using metal deflectors and other seals (see pg. MR-11, tab. 11)

Fig. 18

Type	System [mm]				Slider MRZ [mm]									Weight [kg]	Rail MRR [mm]						Weight [kg/m]	
	H	W	W ₂	H ₂	L	P ₂	P ₁	M	g ₂	L ₁	L ₂	T	S		W ₁	H ₁	P	d	D	g ₁		L ₃ *
MRZ25W	36	48	12.5	7	90.3	35	35	M6	10	57	15.6	M6x1	7.8	0.4	23	22	60	7	11	9.5	20	3.6
MRZ25LW					113	35	50		8	79.1				0.5								

* Only applies when using max. rail lengths (see Ordering key)

Tab. 11

> MRR...F – rails mounted from below

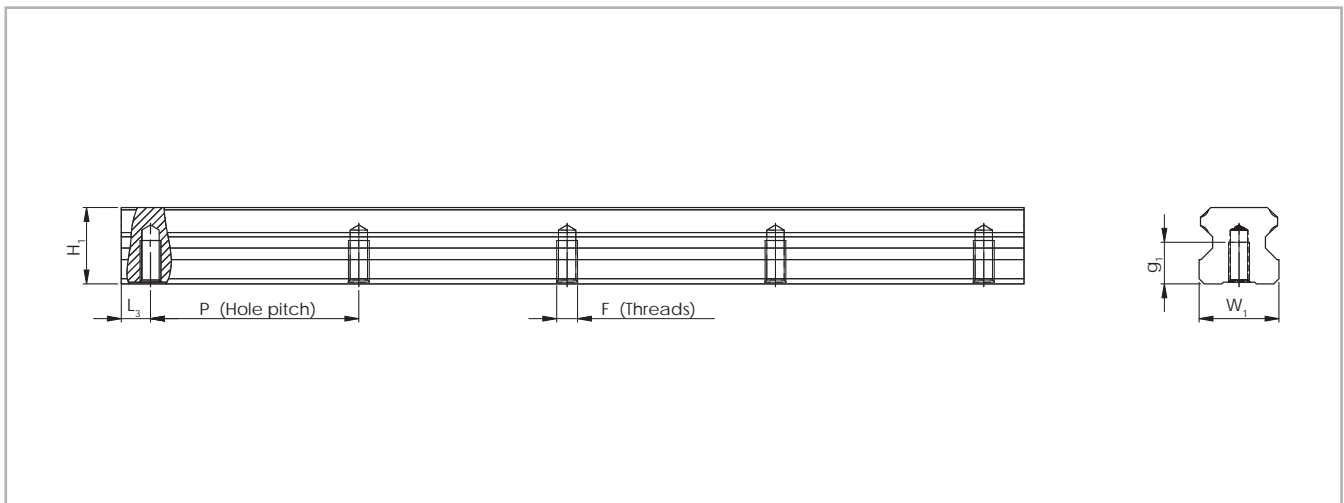

Fig. 19

Rail type	W_1 [mm]	H_1 [mm]	L_3^* [mm]	P [mm]	F	g_1 [mm]
MRR15...F	15	14	20	60	M5	8
MRR20...F	20	18			M6	10
MRR25...F	23	22		M8	12	
MRR30...F	28	26		80	15	
MRR35...F	34	29	22.5	105	M12	17
MRR45...F	45	38				24

* Only applies when using max. rail lengths (see Ordering key)

Tab. 12

> Miniature Mono Rail standard width

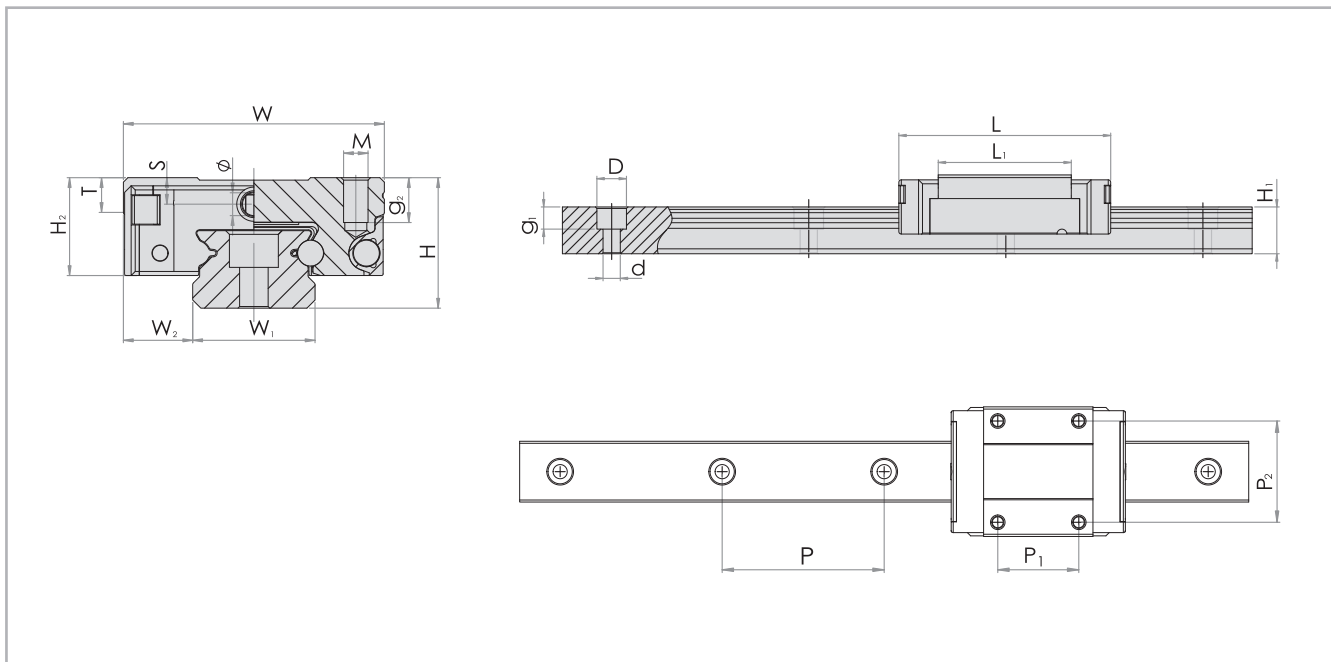

Fig. 20

Type	System [mm]			
	H	W	W ₂	H ₂
MR07MN	8	17	5	6.5
MR09MN	10	20	5.5	7.8
MR12MN	13	27	7.5	10
MR15MN	16	32	8.5	12

Tab. 13

Type	Slider [mm]										Rail [mm]						
	L	P ₂	P ₁	M	g ₂	L ₁	T	S	∅	Weight [kg]	W ₁	H ₁	P	d	D	g ₁	Weight [kg/m]
MR07MN	23.7	12	8	M2	2.5	14.3	2.8	1.6	1.1	0.008	7	4.7	15	2.4	4.2	2.3	0.215
MR09MN	30.6	15	10	M3	3.0	20.5	3.3	2.2	1.3	0.018	9	5.5	20	3.5	6	3.5	0.301
MR12MN	35.4	20	15	M3	3.5	22.0	4.3	3.2	1.3	0.034	12	7.5	25	3.5	6	4.5	0.602
MR15MN	43.0	25	20	M3	5.5	27.0	4.3	3.3	1.8	0.061	15	9.5	40	3.5	6	4.5	0.93

Tab. 14

> Miniature Mono Rail large width

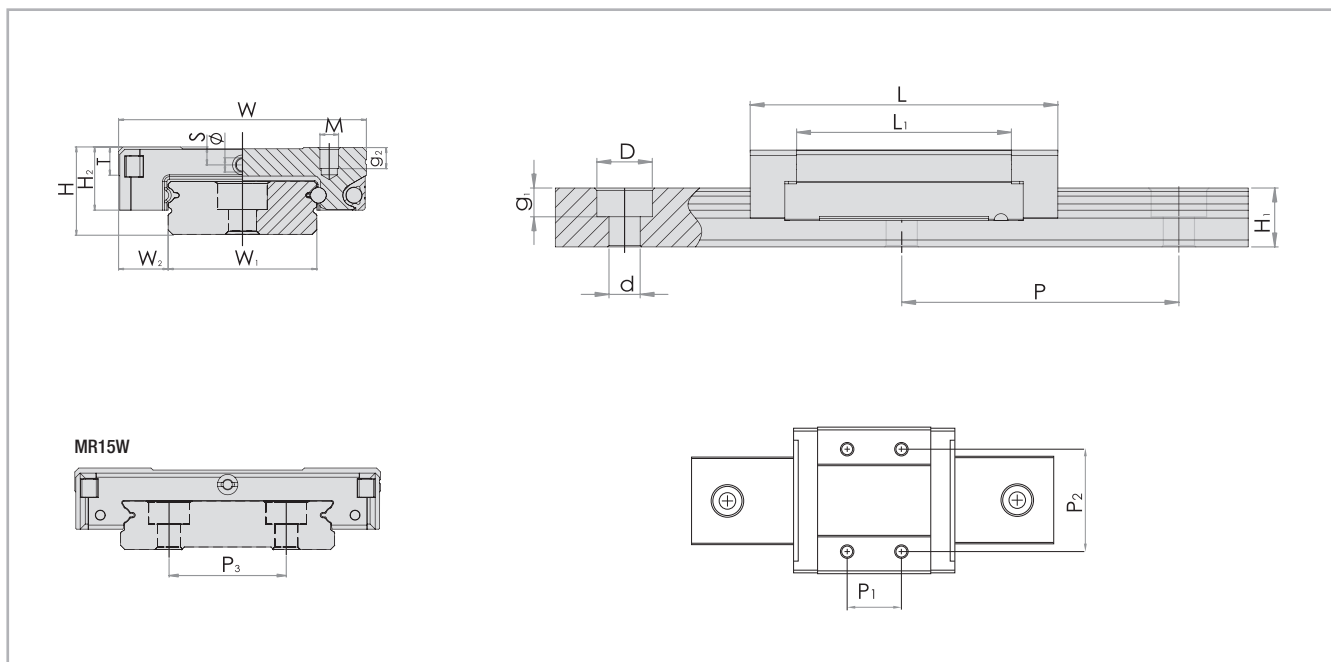

Fig. 21

Type	System [mm]			
	H	W	W ₂	H ₂
MR09WN	12	30	6	8.6
MR12WN	14	40	8	10.1
MR15WN	16	60	9	12

Tab. 15

Type	Slider [mm]										Rail [mm]							
	L	P ₂	P ₁	M	g ₂	L ₁	T	S	Ø	Weight [kg]	W ₁	H ₁	P	P ₃	d	D	g ₁	Weight [kg/m]
MR09WN	39.1	21	12	M3	3	27.9	4	2.6	1.3	0.037	18	7.3	30	-	3.5	6		0.94
MR12WN	44.4	28	15	M3	3.5	31.0	4.5	3.1	1.3	0.065	24	8.5	40	-	4.5	8	4.5	1.472
MR15WN	55.3	45	20	M4	4.5	38.5	4.5	3.3	1.8	0.137	42	9.5	40	23	4.5	8		2.818

Tab. 16

Accessories

> Safety equipment and covers

End seal

Carriages of Mono Rail profile rails are equipped with end seals for contamination protection as standard.

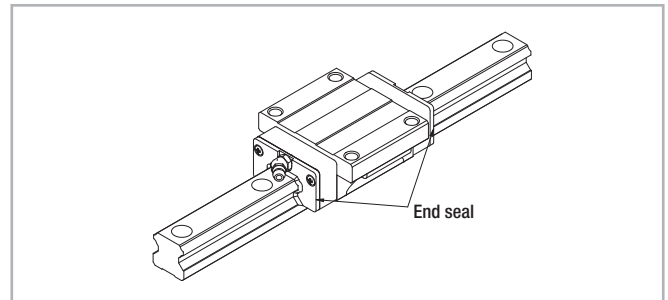

Fig. 22

Side seal

To prevent permeation of foreign matter from below, the carriages for this area are offered with appropriate seals.

No side seals are available for carriages in long or short version (...S / S...W and ...L / L...W).

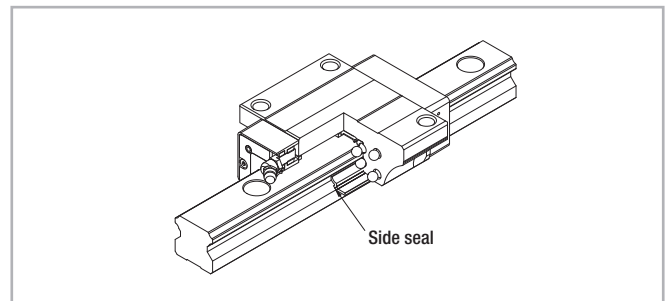

Fig. 23

Double seal

To improve the protection from contamination at higher loads the carriage can be provided with double end seals.

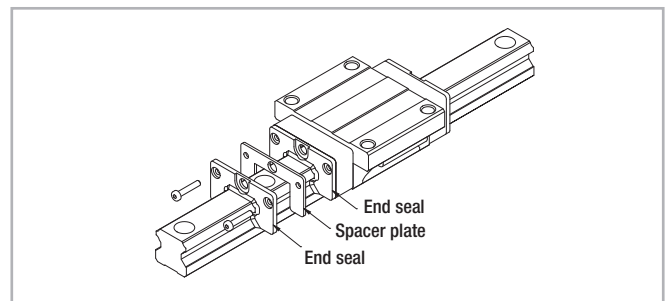

Fig. 24

Metal deflector (non-contacting)

Metal cuttings or coarse contamination can damage the end seals of the carriage. Metal deflector covers protect seal lips against damage.

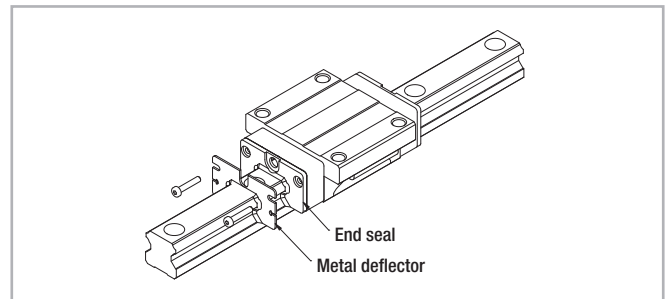

Fig. 25

Seal variants:

A: Carriage with end and side seal

C: Carriage with end and side seals and metal deflector

D: Carriage with double end seal and side seal

E: Carriage with double end seal and side seal and metal deflector

Changes of floor clearance and length changes of the carriages when using the corresponding seal variants

Seal variant		A, C, D, E,	A	C	D	E
Slider type ¹	Size	Changed dimension H ₂ * [mm]	Changed length L* [mm]			
MRS MRS...W MRT MRT...W	15	2.5	73	75	79	83
	20	2.9	85	87	91	95.2
	25	4.9	94.7	97.7	101.4	106.6
	30	6.9	117	119	132	136
	35	7.6	118	120	128	132.6
	45	12.05	146.7	148.7	157.4	161.9
MCS MCS...W MCT MCT...W	55	-	-	192	191	200
MRS...L MRS...LW MRT...LW	20	-	-	99.5	103.5	107.7
	25	-	-	117.7	121.4	126.6
	30	-	-	138.3	151.3	155.3
	35	-	-	143.6	151.6	156.2
	45	-	-	171.2	179.9	184.4
MCS...L MCS...LW MCT...LW	55	-	-	234.2	233.2	242.2
MRT...S MRT...SW	15	-	-	54.6	58.6	62.6
	20	-	-	64.1	68.1	72.3
	25	-	-	70.2	73.9	79.1
	30	-	-	83	96	100
	35	-	-	83.7	91.7	96.3

Tab. 17

¹ No side seals are available for carriages in long or short version (...S / S...W and ...L / L...W)

* For comparison see Chapter 3 Product dimensions, pg. MR-8ff

> Metal cover strip

A rail cover strip made of corrosion resistant steel is available to improve the seal after guide rail installation. The metal cover strip is 0.3 mm wide and can have a maximum length of 50 m.

Size	Width [mm]
15	10
20	13
25	15
30	20
35	24
45	32
55	38

Tab. 18

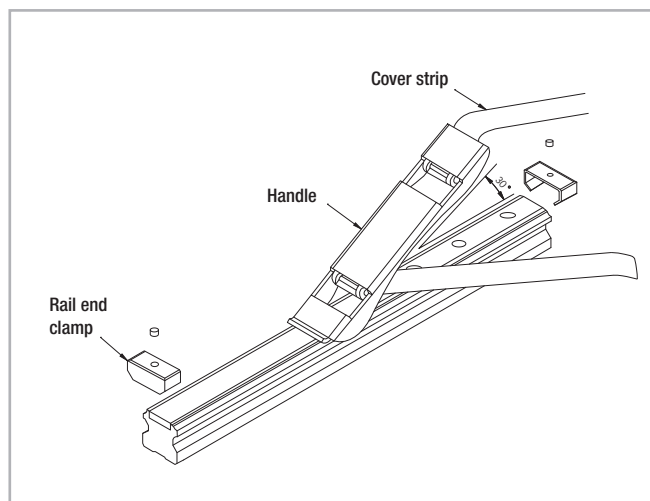

Fig. 26

> Flush cap

Metal debris and other foreign substance can collect in the fixing holes of the rails and thus end up the carriage.

To prevent penetration of contamination in the carriage, the fixing holes should be capped with perforated caps flush with the rail surface.

Flush caps are made of wear and oil resistant synthetic resin. Various sizes of perforated caps for the counter sunk holes for hexagon socket bolts M3 to M22 are included as standard in the scope of supply.

Flush caps are driven in flush with the rail surface with light hammer taps using a flat piece of metal (see fig. 27).

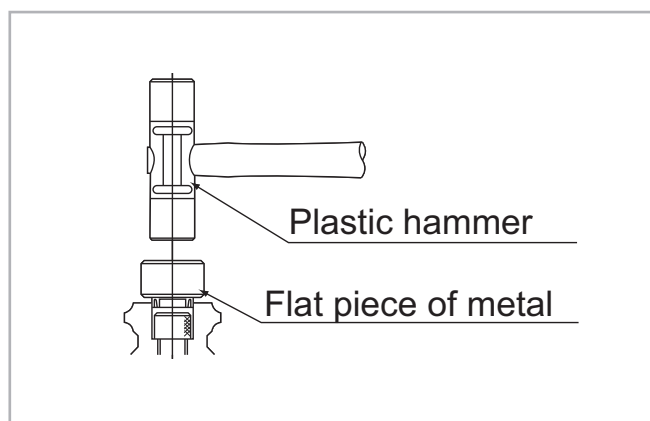

Fig. 27

> Clamping elements

Mono Rail profile rails can be secured with manual or pneumatic clamping elements. Areas of application are:

- Table cross beams and sliding beds
- Width adjustment, stops
- Positioning of optical equipment and measuring tables

Manual clamp elements HK

The HK series is a manually activated clamping element.

Contact profiles press synchronously on the free surfaces of the profile rail by using the freely adjustable clamping lever.

The floating mounted contact profiles guarantee symmetrical introduction of force on the guide rail.

Special characteristics of the clamping elements HK:

- Simple and safe design
- Floating contact profile
- Precise positioning
- Holding force up to 2,000 N

Variants:

An additional adapter plate must be used depending on the height of the carriage (see pg. MR-21, tab. 21).

Activation:

Standard with hand lever, further activation options, e.g. using DIN 912 screw, possible on request.

Pneumatic clamp elements MK / MKS

The patented wedge slide gear puts into effect high holding forces. The pressurised medium moves the wedge slide gear in the longitudinal direction.

Contact profiles press with high force on the free surfaces of the profile rail by the resulting cross movement. MK is an element that closes with pneumatic pressure. The custom design MKS closes with spring energy storage and is opened via air impingement.

Special characteristics of clamp elements MK / MKS:

- Short shape
- High clamp forces
- Precise positioning
- High axial and horizontal rigidity

Areas of application of MK:

- Positioning axes
- Setting vertical axes
- Positioning lifting gear
- Clamping machine tables

Variants:

An additional adapter plate must be used depending on the height of the carriage (see pg. MR-21, tab. 22).

Connection options:

The basic MK / MKS series versions are equipped with air connections on both sides, i.e. the factory default settings air connections and the ventilation filter can be exchanged to the opposite side surfaces.

Custom design MKS opens with impingement of an air pressure of > 5.5 bar.

Areas of application of MKS:

- Clamping with drop in pressure (Normally Open)
- Clamping without power required (Normally Closed)

> Manual clamp HK

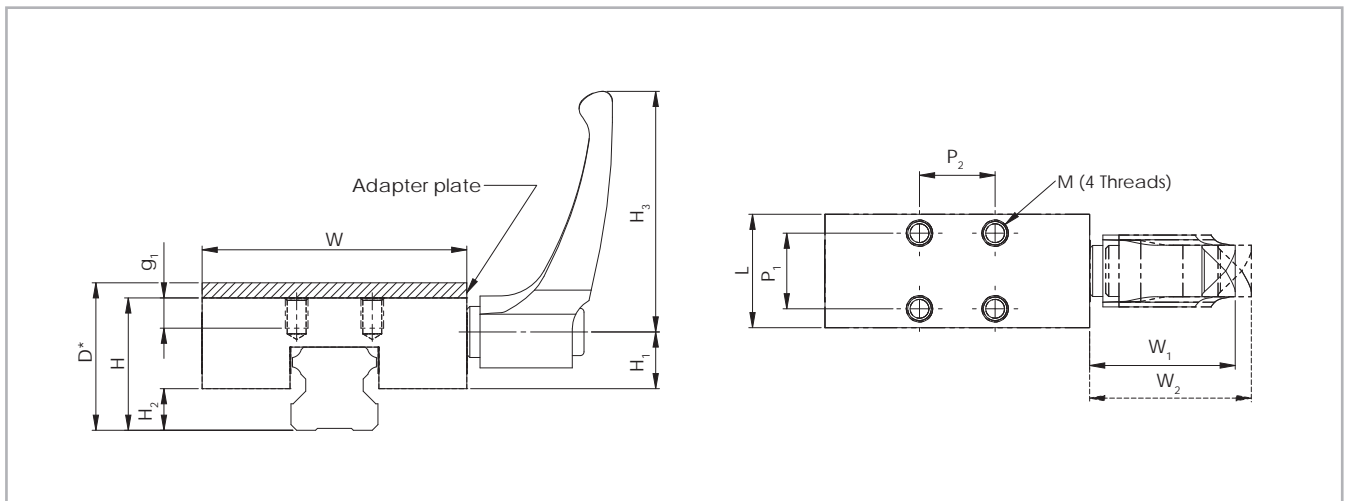

* Changed dimensions when using the adapter plate, see pg. MR-21, tab. 21

Fig. 28

Type	Size	Holding force [N]	Tightening torque [Nm]	Dimensions [mm]											M
				H	H ₁	H ₂	H ₃	W	W ₁	W ₂	L	P ₁	P ₂	g ₁	
HK1501A	15	1200	5	24	12.5	6.5	44	47	30.5	33.5	25	17	17	5	M4
HK2006A	20			28	17.5	5		60			24	15	15	6	
HK2006A				30	7	70	38.5	41.5	30	20	20	8	M6		
HK2501A	25	2000	7	36	15	12	63	70	38.5	41.5	30	22		22	10
HK2514A				33		11.5							80		
HK3001A	30			42	21.5	12	78	90	46.5	50.5	39	24	24	10	14
HK3501A	35	48	16	100		26		26							
HK4501A	45	60	26.5	18	95	120	56.5	61.5	49	30	30	16	M14		
HK5501A	55	22	70	31		21								140	

Tab. 19

> Pneumatic clamp MK / MKS

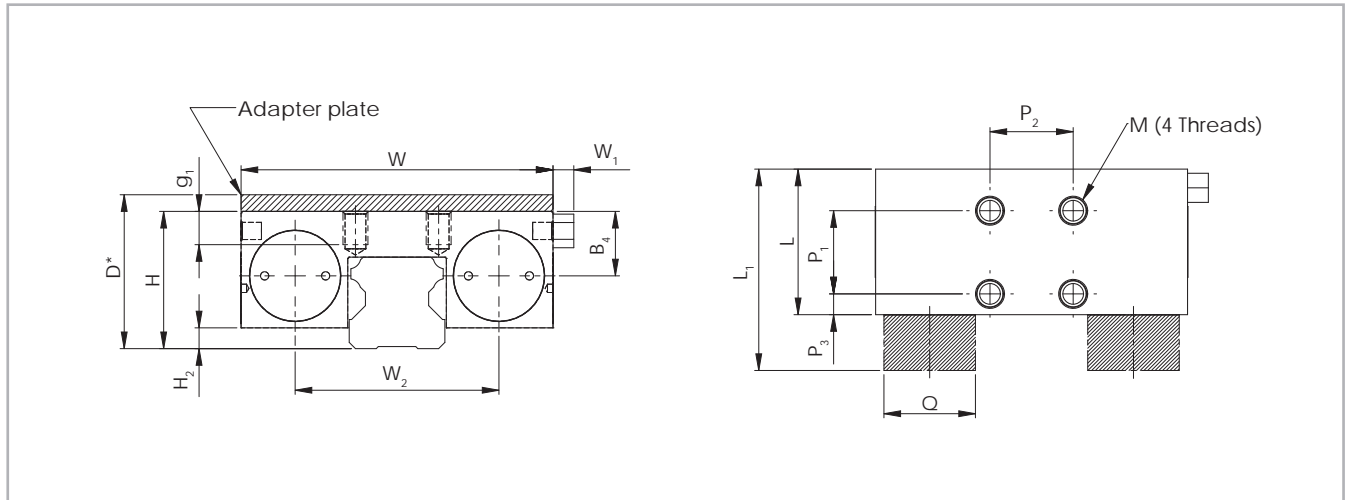

* Changed dimensions when using the adapter plate, see pg. MR-21, tab. 22

Fig. 29

Type	Size	MK holding force [N]	MKS holding force [N]	Dimensions [mm]													M
				H	H ₂	W	W ₁	W ₂	B ₄	L ₁ *	L	P ₁	P ₂	P ₃	Q [Ø]	g ₁	
MK / MKS 1501A	15	650	400	24	2.5	55	6	34	12	58	39	15	15	15.5	16	4.5	M4
MK / MKS 2001A	20	1000	600	28		66		43	14.4	61		20	20	5	20	5	M5
MK / MKS 2501A	25	1200	750	36	8	75	5	49	15.5	56	35	22	22	8.5	25	10	M6
MK / MKS 3001A	30	1750	1050	42	7	90		58	20.5	68	39	24	24	7.5	28	10	M8
MK / MKS 3501A	35	2000	1250	48	11.5	100	68	26.8	67	49	26	26	11.5	30	15	M10	
MK / MKS 4501A	45	2250	1450	60	16.5	120	78.8	82	82	49	30	30	9.5	30	18	M10	
MK / MKS 5501A	55			70	21.5	128	87	30.5	87	30.5	87	49	30	30	9.5	30	18

* Only for model MKS

Tab. 20

> Adapter plate

For HK clamps

Clamp	Size	Slider type	Adapter plate	D
HK1501A	15	MRS, MRT...W, MRT...SW	-	24
		MRS...W	PHK 15-4	28
HK2006A	20	MRT...S, MRT...W, MRT...SW	-	28
		MRS, MRS...L, MRS...W, MRS...LW	PHK 20-2	30
HK2514A	25	MRT, MRT...S, MRT...W, MRT...SW, MRT...LW	-	33
HK2501A		MRS, MRS...L,	-	36
		MRS...W, MRS...LW	PHK 25-4	40
HK3001A	30	MRS, MRS...L, MRT...W, MRT...SW, MRT...LW	-	42
		MRS...W, MRS...LW	PHK 30-3	45
HK3501A	35	MRS, MRS...L, MRT...W, MRT...SW, MRT...LW	-	48
		MRS...W, MRS...LW	PMK 35-7	55
HK4501A	45	MRS, MRS...L, MRT...W, MRT...LW	-	60
		MRS...W, MRS...LW	PHK 45-10	70
On request	55	MRT...W, MRT...LW	-	68
HK5501A		MRS, MRS...L	-	70
		MRS...W, MRS...LW	PHK 55-10	80

Tab. 21

For MK / MKS clamps

Clamp	Size	Slider type	Adapter plate	D
MK / MKS 1501A	15	MRS, MRT...W, MRT...SW	-	24
		MRS...W	PMK 15-4	28
MK / MKS 2001A	20	MRT...S, MRT...W, MRT...SW	-	28
		MRS, MRS...L, MRS...W, MRS...LW	PMK 20-2	30
On request	25	MRT, MRT...S, MRT...W, MRT...SW, MRT...LW	-	33
MK / MKS 2501A		MRS, MRS...L, MRZ	-	36
		MRS...W, MRS...LW	PMK 25-4	40
MK / MKS 3001A	30	MRS, MRS...L, MRT...W, MRT...SW, MRT...LW	-	42
		MRS...W, MRS...LW	PMK 30-3	45
MK / MKS 3501A	35	MRS, MRS...L, MRT...W, MRT...SW, MRT...LW	-	48
		MRS...W, MRS...LW	PMK 35-7	55
MK / MKS 4501A	45	MRS, MRS...L, MRT...W, MRT...LW	-	60
		MRS...W, MRS...LW	PMK 45-10	70
On request	55	MRT...W, MRT...LW	-	68
MK / MKS 5501A		MRS, MRS...L	-	70
		MRS...W, MRS...LW	PMK 55-10	80

Tab. 22

Technical instructions



> Mono Rail precision

Precision means the guide accuracy or the maximal deviation of the carriage based on the side and support surfaces during the movement along the rails.

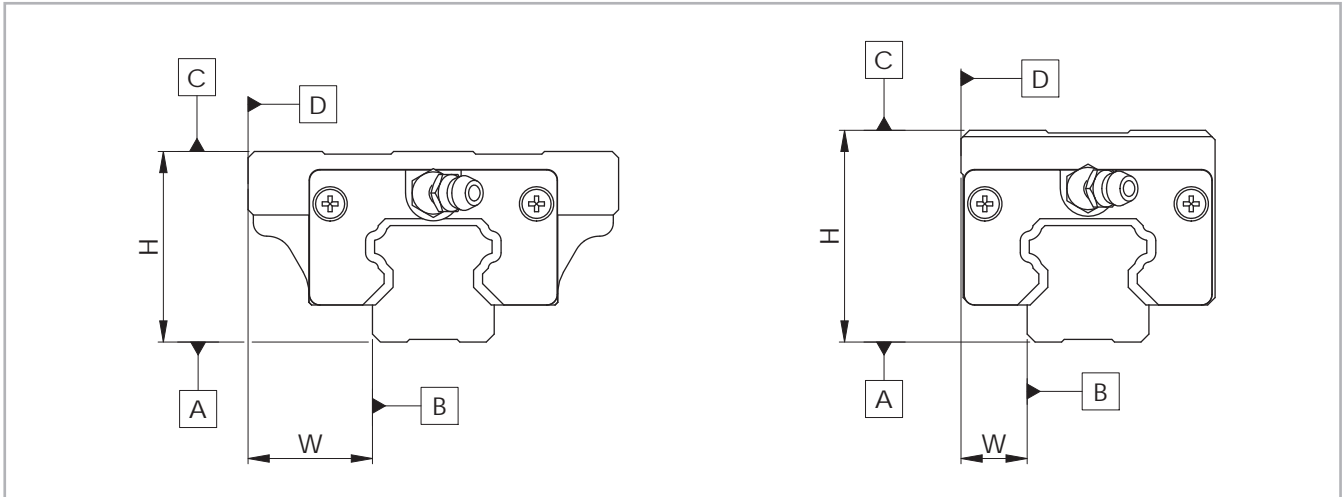

Fig. 30

	Precision class [mm]		
	Normal [N]	High [H]	Precise [P]
Height tolerance H	± 0.1	± 0.04	0 to -0.04
Side tolerance W			
Height difference (Δ H)	0,03	0,02	0,01
Width difference (Δ W)			
Guide accuracy of raceway C based on surface A	ΔC see graph in fig. 31		
Guide accuracy of raceway D based on surface B	ΔD see graph in fig. 31		

Tab. 23

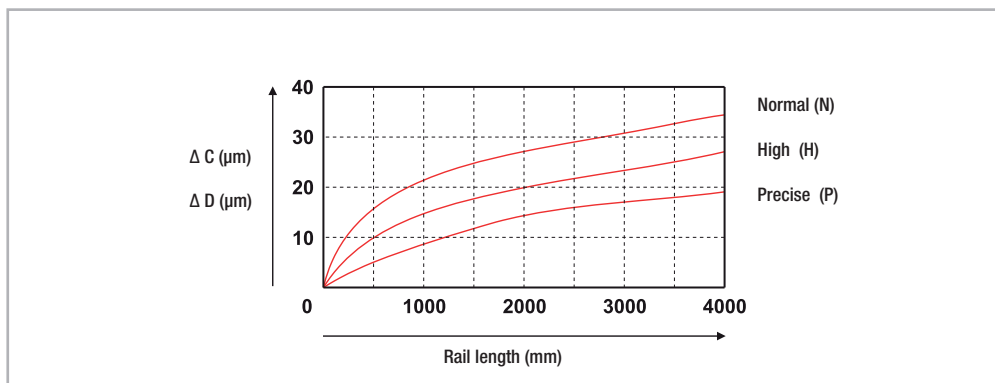

Fig. 31

> Miniature Mono Rail precision

There are three precision classes to choose from for the Mono Rail Miniature profile rails: Classes P, H, and N are manufactured.

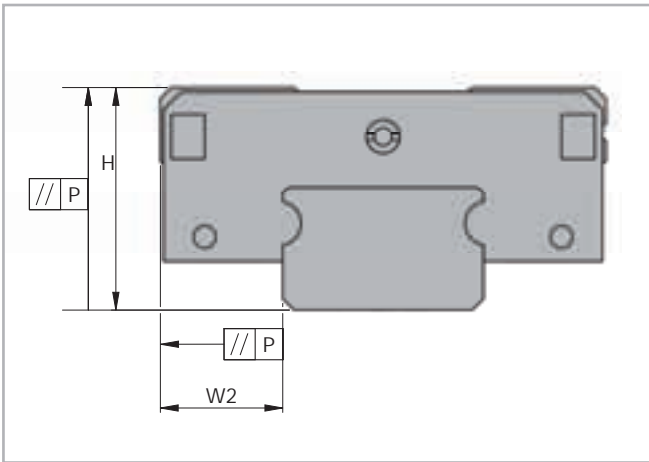

Fig. 32

	Precision classes	Precision P [μm]	High H [μm]	Normal N [μm]
H	Tolerance of height H	± 10	± 20	± 40
ΔH	Permissible height difference of different carriages at the same position on the rail	7	15	25
W₂	Tolerance of width W ₂	± 15	± 25	± 40
ΔW_2	Permissible width difference of different carriages at the same position on the rail	10	20	30

Tab. 24

Running accuracy

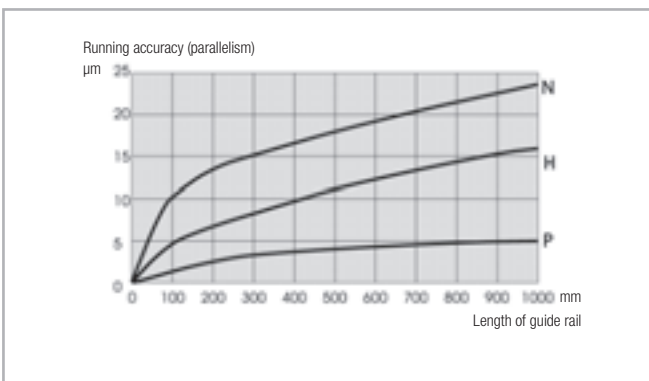

Fig. 33

> Mono Rail Radial clearance / preload

Radial clearance describes the value for the radial movement of the carriage at a constant vertical load, while the carriage moves in longitudinal direction.

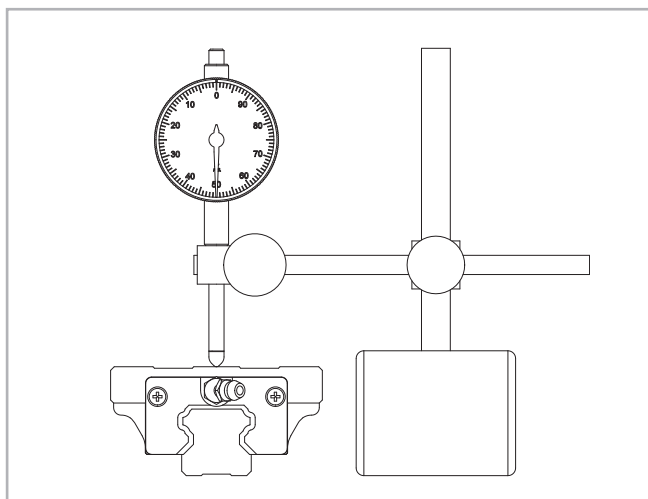

Fig. 34

Preload is defined as an effective load on the rolling element in the interior of the carriage in order to remove an existing clearance or to increase the rigidity.

The Mono Rail profile rails are available in the four different preload classes G1, K0, K1 and K2 (see tab. 25). The preload influences the rigidity, precision and torque resistance and also affects the service life and displacement force.

The radial clearance for the respective preload classes are listed in table 26.

Degree of preload	Preload class	Preload
With clearance	G1	0
No clearance	K0	0
Small preload	K1	0,02 x C*
Average preload	K2	0,05 x C*

* C is the dynamic load capacity, see pg. MR-9, tab. 1f

Tab. 25

Size	Radial clearance of the preload classes [µm]			
	G1	K0	K1	K2
	Impact free movement, compensation of assembly tolerances	Impact free and easy movement	Small moments, one rail application, low vibrations	Average vibrations and moments, light impacts
15	+4 to +14	-4 to +4	-12 to -4	-20 to -12
20	+5 to +15	-5 to +5	-14 to -5	-23 to -14
25	+6 to +16	-6 to +6	-16 to -6	-26 to -16
30	+7 to +17	-7 to +7	-19 to -7	-31 to -19
35	+8 to +18	-8 to +8	-22 to -8	-35 to -22
45	+10 to +20	-10 to +10	-25 to -10	-40 to -25
55	+12 to +22	-12 to +12	-29 to -12	-46 to -29

Tab. 26

> Miniature Mono Rail Preload

The Mono Rail Miniature profile rails are available in the three different preload classes V_0 , V_s and V_1 (see table 27). The preload influences the rigidity, precision and torque resistance and also affects the product service life and displacement force.

Type	Preload classes		
	Small clearance Very quiet running V_0 $[\mu\text{m}]$	Standard Very quiet and precise running V_s $[\mu\text{m}]$	Small preload High rigidity, vibration reduced, high precision, good load balance V_1 $[\mu\text{m}]$
MR07	from +5 to +2	from +1 to -2	from -2 to -4
MR09	from +5 to +2	from +2 to -2	from -2 to -5
MR12	from +6 to +2	from +2 to -2	from -2 to -5
MR15	from +7 to +2	from +2 to -3	from -2 to -6

Tab. 27

> Anticorrosive protection

There are numerous application-specific surface treatments available for profile rails of the Mono Rail product family, for example, black coating (X) or nickel plating (NIC), also with FDA-approval for use in the food industry.

For more information please contact Application Technology. All linear rails of the Miniature Mono Rail series are made of stain less steel.

> Mono Rail lubrication

Profile rails must generally be lubricated before commissioning. They can be lubricated with oil or grease.

The correct lubricant selection has a large influence on the service life and the function of the profile rail, insufficient lubrication and tribocorrosion can ultimately lead to total failure.

As well as reducing friction and wear, lubricants also serve as sealant, noise damper and corrosion protection for the linear guide. Different lubricants for special applications are available upon request.

Example: Lubricant with FDA approval for use in the food industry.

For more information please contact Application Technology.

Important instructions for lubrication

- Mono Rail profile rails must be lubricated for operation.
- The carriage must be moved back and forth during lubrication.
- The lubricant is inserted through a lubrication nipple.
- There should be a thin film of lubricant on the rail surface at all times.
- Please inform us in advance if the guides are to be used in acid or base containing environments or in clean rooms.
- Primary lubricated systems have an increased displacement resistance.
- Please contact Application Technology if the oil lubrication is used for vertical use.
- If the stroke is < 2 or > 15 times the carriage length, the lubrication intervals should be shortened.

Grease lubrication

We recommend the use of a lithium emulsified lubricant NLGI Class 2 for lubrication.

Oil lubrication

We recommend a synthetic oil for operating temperatures between 0 °C and +70 °C. For application-specific custom lubrication, please contact Application Technology.

Relubrication

- Relubrication of the system must be done before the lubricant used is dirty or shows discolouration.
- Relubrication is performed at operating temperature. The carriage must be moved back and forth during relubrication.
- If the stroke is < 2 or > 15 times the carriage length, the lubrication intervals should be more often.

Lubrication intervals

Operating speed, stroke length and ambient conditions influence the selection of time between lubrication intervals. Establishing a safe lubrication interval is based exclusively on the experienced practiced values determined on site. However, a lubrication interval should not be longer than one year in any case.

> Miniature Mono Rail lubrication

Function

The contact points between ball and track are separated from each other by a microscopically thin oil film. The lubrication effects:

- Reduction of friction
- Reduction of wear
- Corrosion protection
- Better thermal distribution and therefore increased of service life

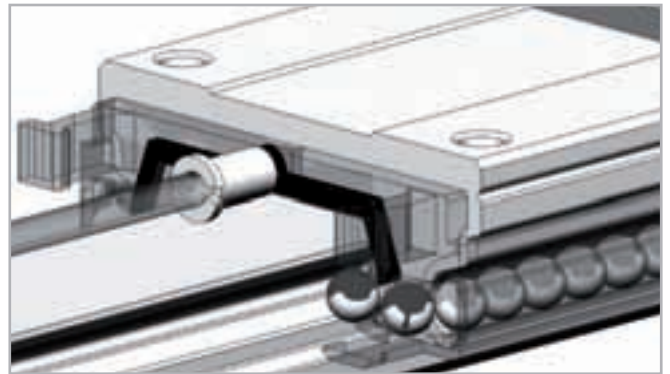

Fig. 35

Important instructions for lubrication

- Mono Rail Miniature profile rails must be lubricated for operation.
- The carriage must be moved back and forth during lubrication.
- The lubricant can also be applied to the tracks.
- The lubricant can be injected into the lubrication holes on both sides of the carriage.
- There should be a thin film of lubricant on the rail surface at all times.
- Please inform us in advance if the guides are to be used in acid or base containing environments or in clean rooms.
- Please contact the sales department if the oil lubrication should be used for vertical use of the guide.
- If the stroke is < 2 or > 15 times the carriage length, the lubrication intervals should be more often.

Type	First lubrication [cm ³]
MR07MN	0.12
MR09MN	0.23
MR12MN	0.41
MR15MN	0.78

Tab. 28

Type	First lubrication [cm ³]
MR09WN	0.30
MR12WN	0.52
MR15WN	0.87

Tab. 29

Grease lubrication

When using grease lubrication, we recommend synthetic-oil based lithium grease with a viscosity according to ISO VG 32 to ISO VG 100.

Oil lubrication

We recommend CLP or CGLP synthetic oil conforming to DIN 51517 or HLP to DIN 51524 and a viscosity range conforming to ISO VG 32 to ISO VG 100 for operating temperatures between 0 °C and +70 °C. We recommend a viscosity according to ISO VG 10 for use at low temperatures. For application-specific special lubrication please contact the Rollon Application engineering department.

ISO VG 10	≙	Viscosity of 10	$\frac{\text{mm}^2}{\text{s}}$	at 40 °C
ISO VG 32	≙	Viscosity of 32	$\frac{\text{mm}^2}{\text{s}}$	at 40 °C
ISO VG 100	≙	Viscosity of 100	$\frac{\text{mm}^2}{\text{s}}$	at 40 °C

Fig. 36

Initial lubrication and relubrication

Self-lubricating

The carriages of the following sizes have a self-lubrication element to extend lubrication intervals.

Size	Initial lubrication grease [cm ³]	Relubrication [cm ³]	Initial lubrication oil [cm ³]
15	1.3	1.1	1.5
20	2.3	2	2.5
25	2.8	2.5	3.5
30	3.5	3	4.5
55	5.5	4	5.5

The given lubrication quantities apply to preload K1 and speeds ≤ 1 m/s

Tab. 30

Lubrication intervals

Operating speed, stroke length and ambient conditions influence the selection of time between lubrication intervals. Establishing a safe lubrication interval is based exclusively on the experienced practiced values determined on site. However, a lubrication interval should not be longer than one year in any case.

Relubrication

- Relubrication of the system must be done before the lubricant used is dirty or shows discolouration.
- An application of approx. 50 % of the quantity used for first lubrication is sufficient for relubrication (see tab. 31).
- Relubrication is performed at operating temperature.
During relubrication, the carriage should be moved back and forth.
- If the stroke is < 2 or > 15 times the carriage length, the lubrication intervals should be more often.

Not self-lubricating

The carriages of sizes 35 and 45 are not self-lubricating due to the design.

Size	Initial lubrication grease [cm ³]	Relubrication [cm ³]	Initial lubrication oil [cm ³]
35	3.5	3	3.5
45	4.5	3.5	4.5

The given lubrication quantities apply to preload K1 and speeds ≤ 1 m/s

Tab. 31

> Mono Rail lubrication nipple

The following lubrication nipples are part of the standard delivery:

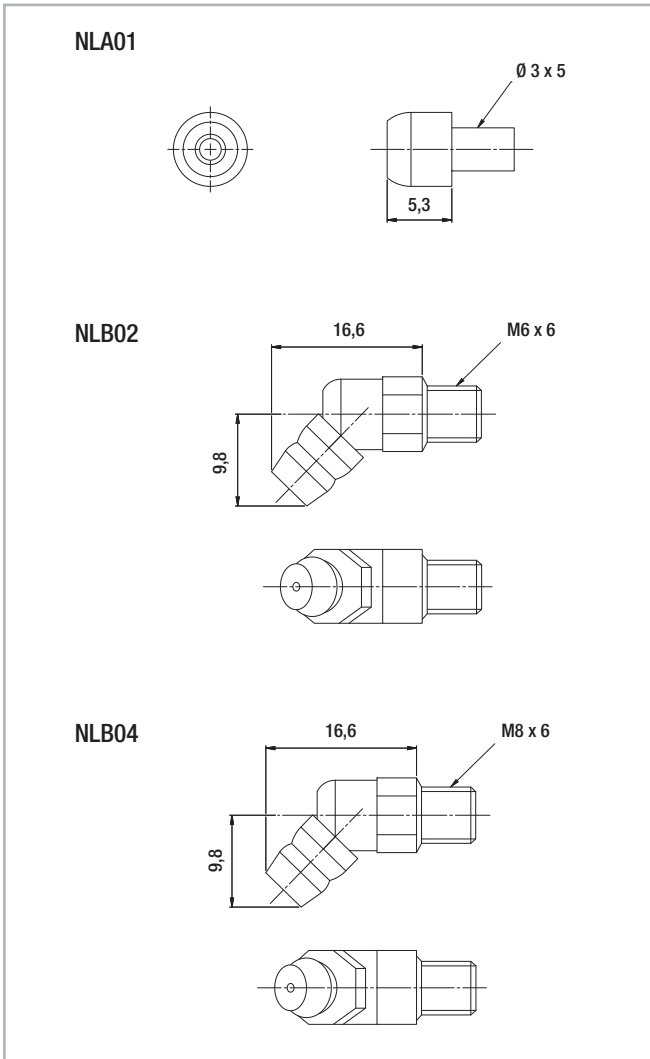

Fig. 37

Lubrication nipple	Size
NLA01	15
NLB02	20
	25
	30
	35
NLB04	45
	55

Tab. 32

Other lubrication nipples, such as lubrication adapters with hose inlet or with quick-coupling, are available on request. Please observe that the thread lengths (see fig. 37) can be changed when using additional deflectors and end seals. For more information please contact Application Technology.

> Friction / displacement resistance

Mono Rail profile rails have a low friction characteristic and thus low displacement resistance. The low start-up friction (breakaway force) is almost identical to the moving friction (running resistance).

The displacement resistance is dependent upon several factors:

- Friction of the sealing system
- Friction of the balls with each other
- Friction between balls and redirection
- Rolling resistance of the balls in the running grooves
- Resistance of lubricant in the carriage
- Resistance by contamination in the lubricant
- Preload for increase of rigidity
- Moment load

Resistance of the seals

Type	f [N]
MRS15	0.15
MRS20	0.2
MRS25	0.35
MRS30	0.7
MRS35	0.8
MRS45	0.9
MCS55	1.0

Tab. 33

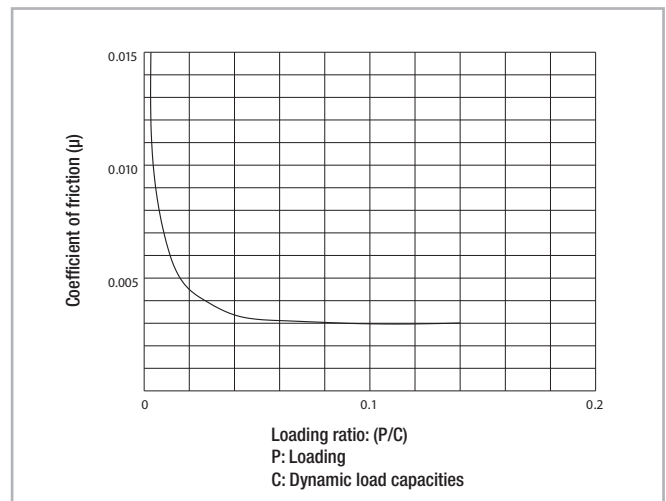

Fig. 38

Displacement resistance

The following formula is used for general approximate calculation of the displacement resistance. Please note that the level of preload or the viscosity of the lubricant used can also influence the displacement resistance.

$F_m = \mu \cdot F + f$	<p> F_m = Displacement resistance (N) F = Load (N) μ = Coefficient of friction f = Resistance of the seals (N) </p>
-------------------------	--

Fig. 39

Mono Rail profile rails have a coefficient of friction of approx. $\mu = 0.002 - 0.003$.

> Mono Rail loading

The given static load capacity for each carriage represents the maximum permissible load value, which if exceeded causes permanent deformations of the raceways and adverse effects of the running properties.

Checking the load must be done as follows:

- through determination of the simultaneously occurring forces and moments for each carriage
- by comparison of these values with the corresponding load capacities.

The ratio of the actual load to maximum permissible load may be as large as the reciprocal of the accepted safety factor, S_0 , at the most.

$\frac{P_{Orad}}{C_{Orad}} \leq \frac{1}{S_0}$	$\frac{P_{Oax}}{C_{Oax}} \leq \frac{1}{S_0}$	$\frac{M_1}{M_x} \leq \frac{1}{S_0}$	$\frac{M_2}{M_y} \leq \frac{1}{S_0}$	$\frac{M_3}{M_z} \leq \frac{1}{S_0}$
--	--	--------------------------------------	--------------------------------------	--------------------------------------

Fig. 40

The above formulas are valid for a single load case.

If two or more forces are acting simultaneously, please check the following formula:

$\frac{P_{Orad}}{C_{Orad}} + \frac{P_{Oax}}{C_{Oax}} + \frac{M_1}{M_x} + \frac{M_2}{M_y} + \frac{M_3}{M_z} \leq \frac{1}{S_0}$	<p>P_{Orad} = effective radial load (N) C_{Orad} = permissible radial load (N) P_{Oax} = effective axial load (N) C_{Oax} = permissible axial load (N) M_1, M_2, M_3 = external moments (Nm) M_x, M_y, M_z = maximum permissible moments in the different loading directions (Nm)</p>
--	--

Fig. 41

Safety factor

Operating conditions	S_0
Normal operation	1 ~ 2
Loading with vibration or shock effect	2 ~ 3
Loading with strong vibration or impacts	≥ 3

Tab. 34

The safety factor S_0 can lie on the lower given limit if the occurring forces can be determined with sufficient precision. If shock and vibration are present, the higher value should be selected. For dynamic applications higher safety is required. Please contact the Application Engineering Department.

> Miniature Mono Rail loading

Static load (P_0) and static moment (M_0)

Permissible static load

The permissible static load of the Mono Rail Miniature profile rail is limited by:

- Static load of each linear guide
- Permissible load of the fixing screws
- Permissible load of all components used in the surrounding construction
- Static safety factor, which is required by the corresponding application

The equivalent static load and the static moment are the largest load, or the largest moment, which are calculated based on formulas 3 and 4.

Static load capacity C_0

The static load capacity C_0 of ball recirculating guides is defined according to DIN 636, Part 2 as the only load which gives a Hertzian stress of 4,200 MPa with the existing lubrication between track and balls in the center of the highest loaded contact surface.

Note: In the loading center, there is a permanent deformation of approx 0.01 % of the ball diameter under this load (according to DIN 636, Part 2).

Static safety factor S_0

When observing the static safety factor S_0 the Mono Rail Miniature profile rails allow a permissible operation and high running precision as is required for each application. Calculation of the static safety factor S_0 : see fig. 42

S_0 static safety factor

C_0 static load capacity in loading direction (N)

P_0 equivalent static load (N)

M_0 static moment in loading direction (Nm)

M equivalent static moment in loading direction (Nm)

$S_0 = C_0 / P_0$	Formula 1	Operating conditions	S_0
$S_0 = M_0 / M$	Formula 2	Normal operation	1 ~ 2
$P_0 = F_{max}$	Formula 3	Loading with vibration or shock effect	2 ~ 3
$M_0 = M_{max}$	Formula 4	High precision and smooth running	≥ 3

Fig. 42

Dynamic load capacity C

If the dynamic loads work vertically on the last zones with equal size and direction, the calculated service life of the linear guide can theoretically reach 100 km piston travel (as per DIN 636, Part 2).

Combined loads in combination with moments

If both loads and moments work on the profile rails, the equivalent dynamic load is calculated with formula 9. According to DIN 636, Part 1, the equivalent load should not exceed ½ C.

Equivalent dynamic load and speed

With changing load and speed, these must be considered individually since each parameter helps determine the service life.

Equivalent dynamic load

If only the load changes, the equivalent dynamic load can be calculated with formula 5.

Equivalent speed

If only the speed changes, the equivalent speed is calculated with formula 6. If speed and load change, the equivalent dynamic load is calculated with formula 7.

Combined dynamic load

With combined exterior load in an arbitrary angle, the equivalent dynamic load is calculated with formula 8.

$P = \sqrt[3]{\frac{q_1 \cdot F_1^3 + q_2 \cdot F_2^3 + \dots + q_n \cdot F_n^3}{100}}$	Formula 5	<ul style="list-style-type: none"> P = equivalent dynamic load (N) q = stroke (in %) F₁ = individual load levels (N) v = average speed (m/min) v̄ = individual speed levels (m/min) F = external dynamic load (N) F_y = external dynamic load – vertical (N) F_x = external dynamic load – horizontal (N) C₀ = static load capacity (N) M₁, M₂, M₃ = external moments (Nm) M_x, M_y, M_z = maximum permissible moments in the different loading directions (Nm)
$\bar{v} = \frac{q_1 \cdot v_1 + q_2 \cdot v_2 + \dots + q_n \cdot v_n}{100}$	Formula 6	
$P = \sqrt[3]{\frac{q_1 \cdot v_1 \cdot F_1^3 + q_2 \cdot v_2 \cdot F_2^3 + \dots + q_n \cdot v_n \cdot F_n^3}{100}}$	Formula 7	
$P = F_x + F_y $	Formula 8	
$P = F_x + F_y + \left(\frac{ M_1 }{M_x} + \frac{ M_2 }{M_y} + \frac{ M_3 }{M_z} \right) \cdot C_0$	Formula 9	

Fig. 43

> Mono Rail service life

Calculation of service life:

The dynamic load capacity C is a conventional variable used for calculating the service life. This load corresponds to a nominal service life of 50 km. The relationship between calculated service life L_{km} (in km), dynamic load capacity C (in N) and equivalent load P (in N) is given in the formula to the right:

$$L_{km} = \left(\frac{C}{P} \cdot \frac{f_c}{f_i} \right)^3 \cdot 50 \text{ km}$$

f_c = contact factor
 f_i = application coefficient

Fig. 44

The equivalent load P corresponds in its effects to the sum of the forces and moments working simultaneously on a slider. If these different load components are known, P results from the equation to the right:

$$P = |P_{0ax}| + |P_{0rad}| + \left(\frac{|M_1|}{M_x} + \frac{|M_2|}{M_y} + \frac{|M_3|}{M_z} \right) \cdot C_{0rad}$$

Fig. 45

Contact factor f_c

The contact factor f_c refers to applications in which several carriages pass the same rail section. If two or more carriages are moved over the same point on a rail, the static and dynamic loading values must be multiplied with the numbers from the table below:

Number of carriages	1	2	3	4	5
f_c	1	0.81	0.72	0.66	0.61

Tab. 35

Application coefficient f_i

The application coefficient f_i can be understood as the dynamic safety factor. Refer to the table below for the values:

Operational conditions	Speed	f_i
Neither external impacts nor vibrations	Low speed $V \leq 15$ m/min.	1 - 1.5
Light impacts or vibrations	Average speed $15 < V \leq 60$ m/min.	1.5 - 2
Average and high external impacts or vibrations	High speed $V > 60$ m/min.	2 - 3.5

Tab. 36

> Miniature Mono Rail service life

An example of a profile rail or a lot of identical profile rails under the same running conditions, which use ordinary materials with normal manufacturer's quality and operating conditions, can reach 90% of the calculated service life (as per DIN 636 Part 2). By taking 50 km traverse as a basis, the dynamic load capacity is usually 20 % over the values as per DIN. The relationship between the two load capacities can be seen from formulas 10 and 11.

Calculation of service life

Formulas 12 and 13 are used for calculating the service life, if equivalent dynamic load and average speed are constant.

$C_{(50)} = 1,26 \cdot C_{(100)}$	Formula 10	L = service life based on 100,000 (m) L _n = service life (h) C = dynamic load capacity (N) P = equivalent dynamic load (N) S = stroke length (m) n = stroke frequency (min ⁻¹) V _m = average speed (m/min)
$C_{(100)} = 0,79 \cdot C_{(50)}$	Formula 11	
$L = \left(\frac{C_{100}}{P}\right)^3 \cdot 10^5$	Formula 12	
$L_h = \frac{L}{2 \cdot s \cdot n \cdot 60} = \frac{L}{V_m} \cdot \left(\frac{C_{100}}{P}\right)^3$	Formula 13	

Fig. 46

> Mono Rail installation instructions

The given radii and shoulder heights in the table must be observed when assembling rails and carriages on the stop edges to ensure perfect seating of carriages or raceways.

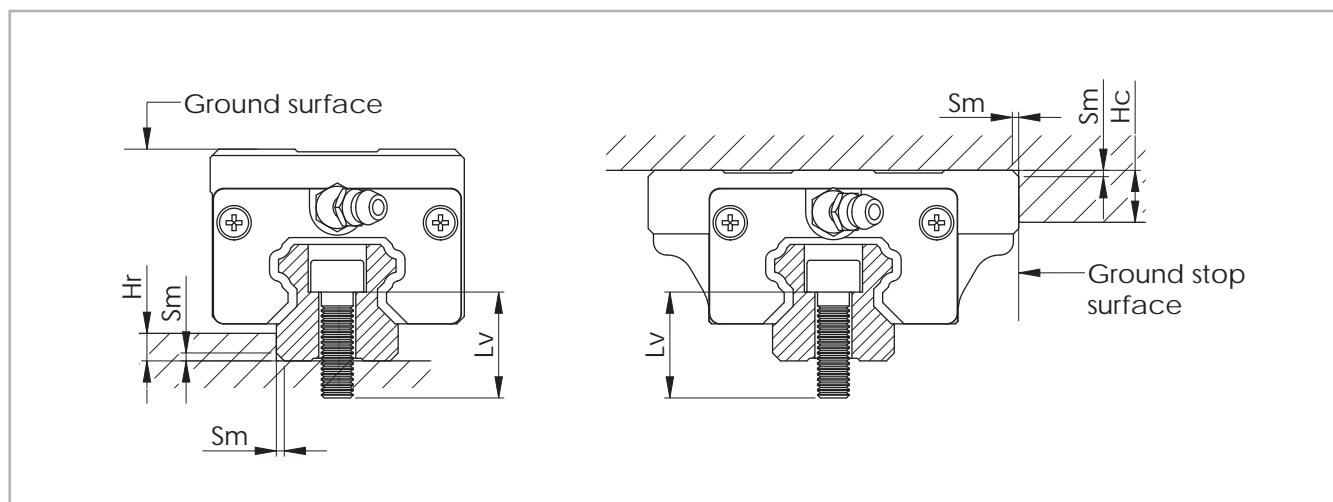

Fig. 47

Size	Maximum level of incline	Maximum height of rail shoulder	Maximum height of rail shoulder when using the side seal	Maximum height of slider shoulder	Required bolt lengths (rails)
	S_m [mm]	H_r [mm]	H_r^* [mm]	H_c [mm]	L_v [mm]
15	0.8	4	1.9	5	M4 x 16
20		4.5	2.4	6	M5 x 20
25		6	3.9	7	M6 x 25
30	1.2	8	5.9	8	M8 x 30
35		8.5	6.6	9	
45	1.6	12	10.5	11	M12 x 40
55		13	-	12	M14 x 45

* For use of various seals, see pg. MR-15, fig. 23ff

Tab. 37

Assembly precision

The maximum permissible deviations of the rail surfaces for assembly are given in the following drawing (see fig. 48) and the table below (see tab. 38):

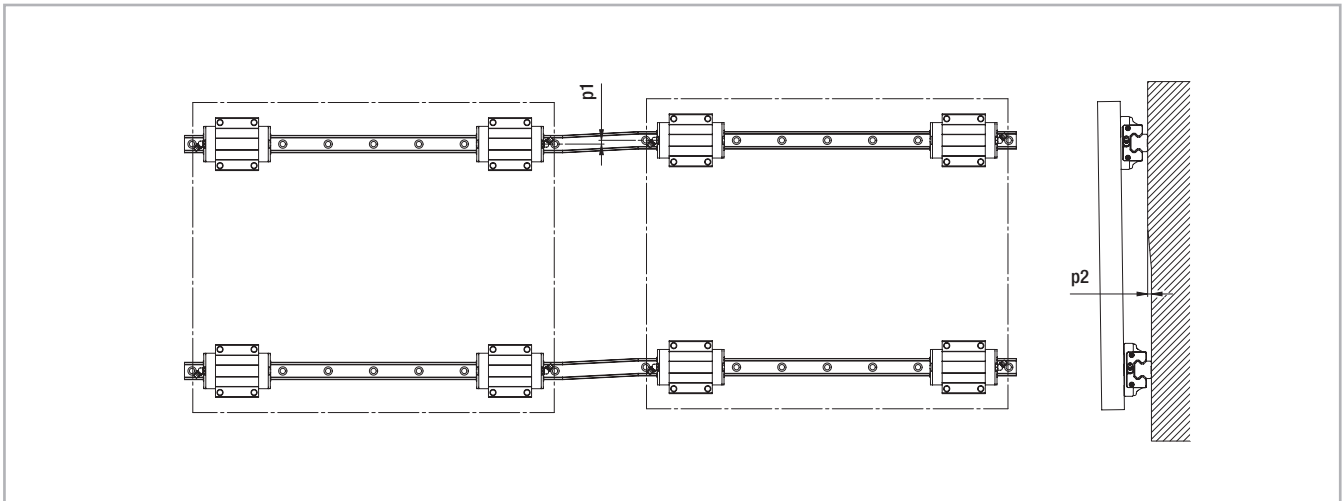

Fig. 48

Size	Permissible tolerance for parallelism p1 [µm]				Permissible tolerance for parallelism p2 [µm]			
	K2	K1	K0	G1	K2	K1	K0	G1
15	-	18	25	35	-	85	130	190
20	18	20			50			
25	20	22	30	42	70	110	170	195
30	27	30	40	55	90			250
35	30	35	50	68	120	150	210	290
45	35	40	60	85	140	170	250	350
55	45	50	70	95	170	210	300	420

Tab. 38

The bolt sizes to be used and optimum tightening torques for rail assembly are listed in the table below (see tab. 39).

Bolt	Tightening torque M_t [Nm]		
	Steel	Cast iron	Aluminium
M4	4	3	2
M5	9	6	4
M6	14	9	7
M8	30	20	15
M12	118	78	59
M14	157	105	78

Tab. 39

> Miniature Mono Rail installation instructions

Shoulder heights and radius of stop edges

Rounding of the stop edges of the surrounding construction should be made so as to avoid contact with the edges of the carriage and the rail. Please observe the following table with the information on the radius and height of the stop surfaces.

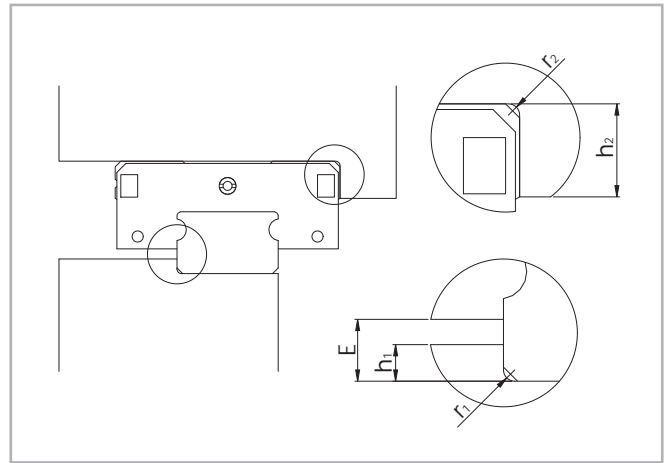

Fig. 49

Dimensions of the stop edges

Type	h_1 [mm]	r_{1max} [mm]	h_2 [mm]	r_{2max} [mm]	E [mm]
MR07M	1.2	0.3	2.8	0.3	1.5
MR09M	1.5	0.3	3	0.3	2.2
MR12M	2.5	0.5	4	0.5	3
MR15M	2.5	0.5	4.5	0.5	4

Tab. 40

Type	h_1 [mm]	r_{1max} [mm]	h_2 [mm]	r_{2max} [mm]	E [mm]
MR09W	2.5	0.3	3	0.3	3.4
MR12W	2.5	0.5	4	0.5	3.9
MR15W	2.5	0.5	4.5	0.5	4

Tab. 41

Geometric and positional accuracy of the mounting surfaces

Inaccuracies of the mounting surface negatively influence the running accuracy and reduce the service life of the Mono Rail Miniature profile rails. If the inaccuracies of the mounting surfaces exceed the values calculated using formulas 14, 15 and 16, the service life is shortened according to formulas 12 und 13.

Mounting surface

The mounting surface should be ground or milled very finely and have a surface roughness of R_a 1.6.

Reference surface

Rail: Both sides of the rails can be used as a reference surface without further marks.

Slider: The reference surface is located across from the running side identified with a notch mark.

Calculation of the positional accuracy

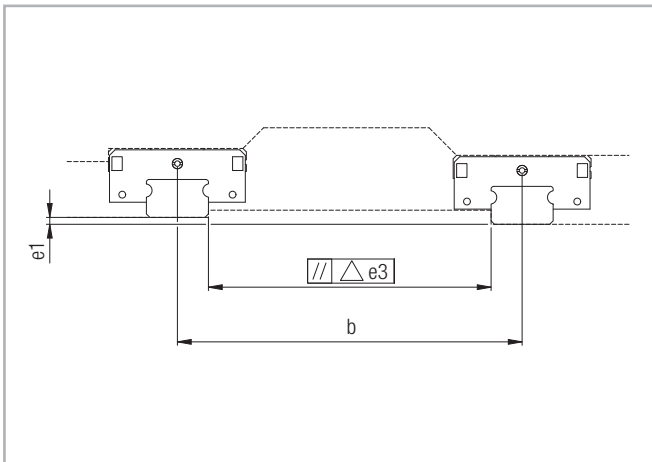

Fig. 50

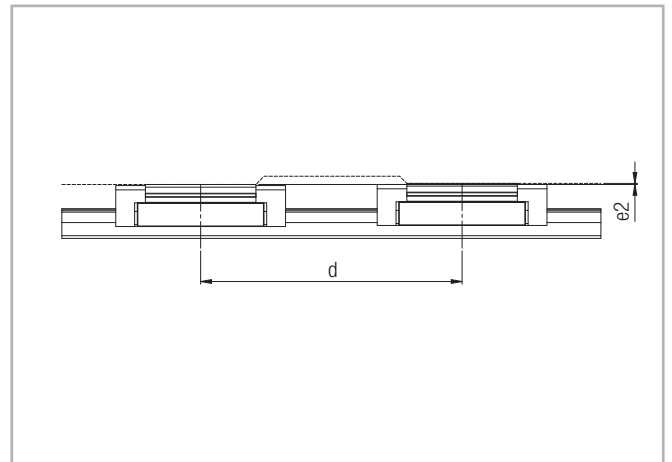

Fig. 51

$e1 \text{ (mm)} = b \text{ (mm)} \cdot f1 \cdot 10^{-4}$ Formula 14
 $e2 \text{ (mm)} = d \text{ (mm)} \cdot f2 \cdot 10^{-5}$ Formula 15
 $e3 \text{ (mm)} = f3 \cdot 10^{-3}$ Formula 16

Fig. 52

Type	V ₀ , V _s			V _i		
	f1	f2	f3	f1	f2	f3
MR07MN	5	11	4	3	10	3
MR09MN	5	11	6	4	10	4
MR12MN	6	13	8	4	12	6
MR15MN	7	11	12	5	10	8

Tab. 42

Type	V ₀ , V _s			V _i		
	f1	f2	f3	f1	f2	f3
MR09WN	2	7	6	2	5	4
MR12WN	3	8	8	2	5	5
MR15WN	2	9	11	1	6	7

Tab. 43

Tightening torque for fixing screws (Nm)

Screw quality 12.9	Steel	Cast iron	Non-ferrous metal
M2	0.6	0.4	0.3
M3	1.8	1.3	1
M4	4	2.5	2

Tab. 44

Composite rails

Guide rails longer than the one part maximum length (see Ordering key), are put together from two or more rails.

When putting guide rails together, be sure that the register marks shown in fig. 53 are positioning correctly.

These are fabricated axisymmetric for parallel application of composite guide rails, unless otherwise specified.

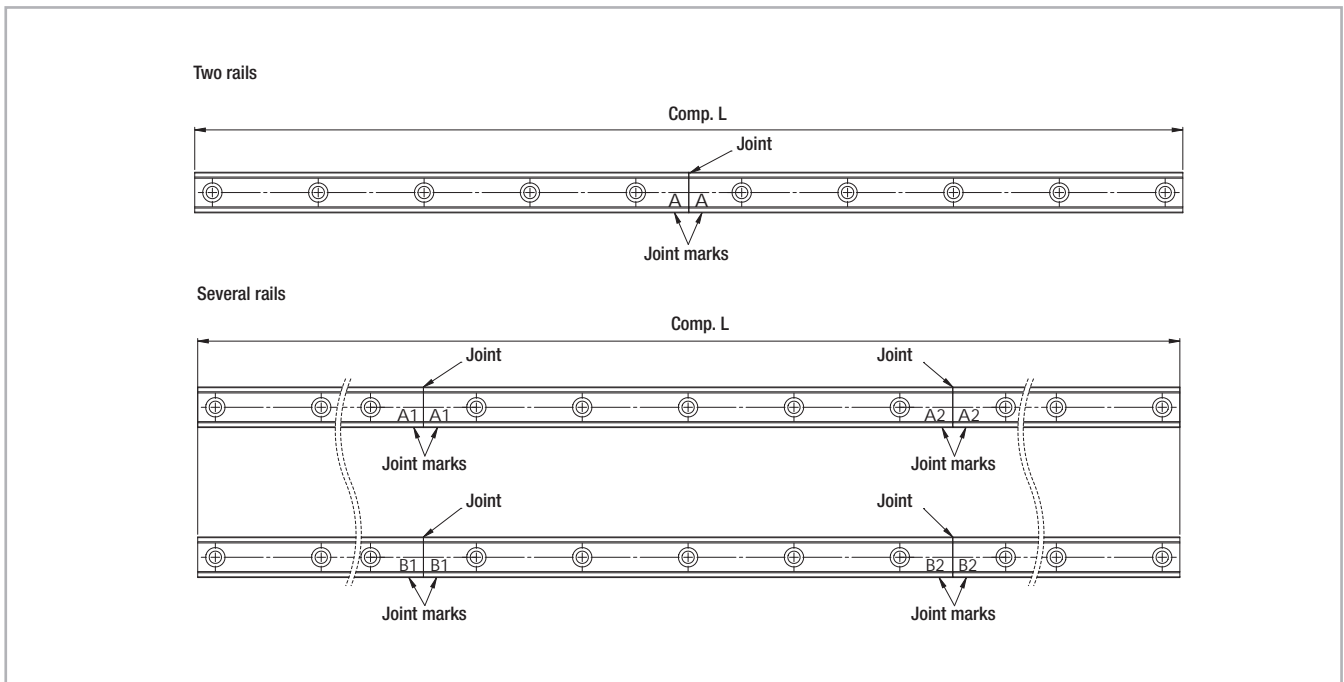

Fig. 53

Assembly process

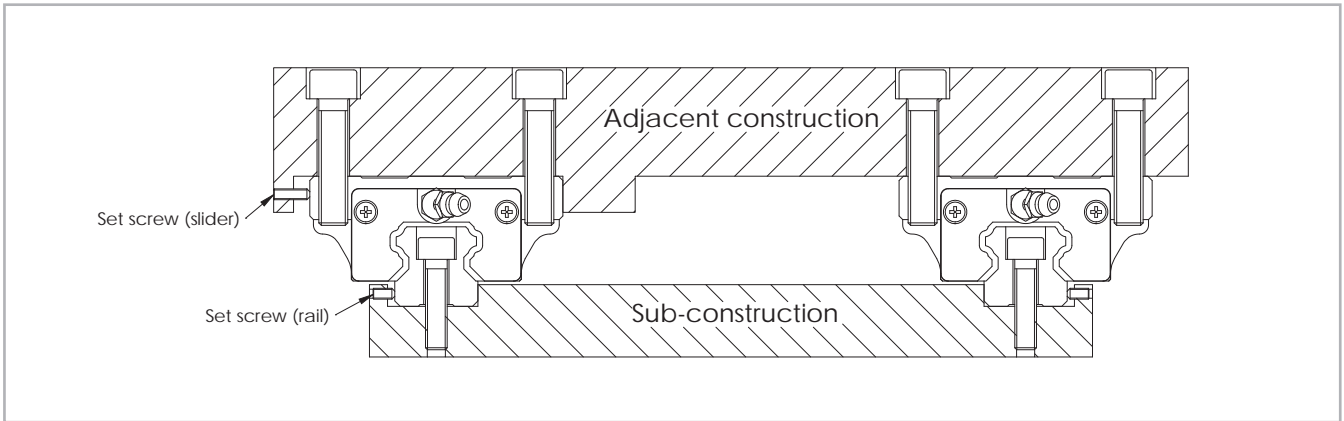

Fig. 54

Fixing guide rails:

(1) Whet the assembly surface with a whetstone and also remove burrs, unevenness and dirt (see fig. 55).

Note: All linear guides are preserved with anticorrosion oil at the factory. This protection must be removed before installation.

In doing so, please ensure that the surfaces are coated with low-viscosity oil for the purpose of further protection against corrosion.

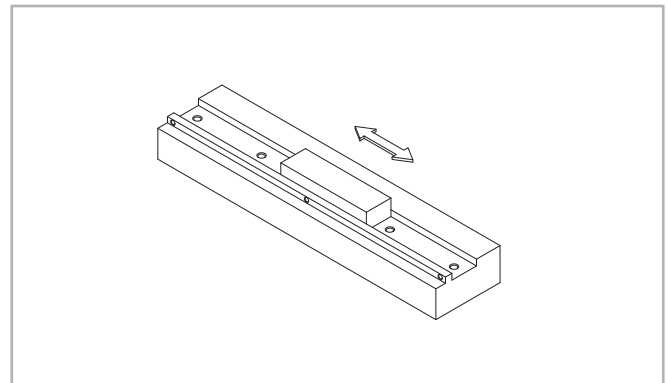

Fig. 55

(2) Carefully lay the guide rail on the assembly surface (see fig. 56) and slightly tighten the fixing screws so that the guide rail lightly touches the assembly surface (align the guide rail along the shoulder edge of the assembly surface, see fig. 57).

Note: The fixing screws of the linear guide must be clean. Check if the fixing holes are located in the correct place when you insert the bolts. A forced tightening of a fixing screw in an offset hole can negatively affect accuracy.

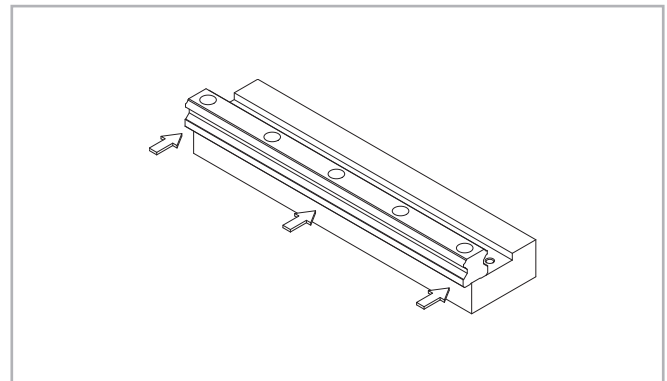

Fig. 56

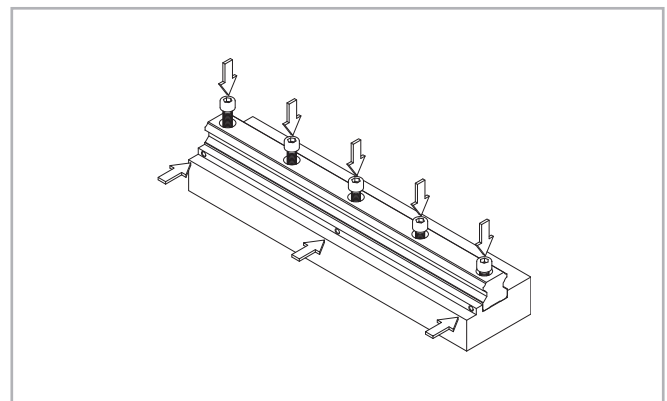

Fig. 57

(3) Tighten the thrust bolts on the guide rail until there is close contact on the side stop surface (see fig. 58).

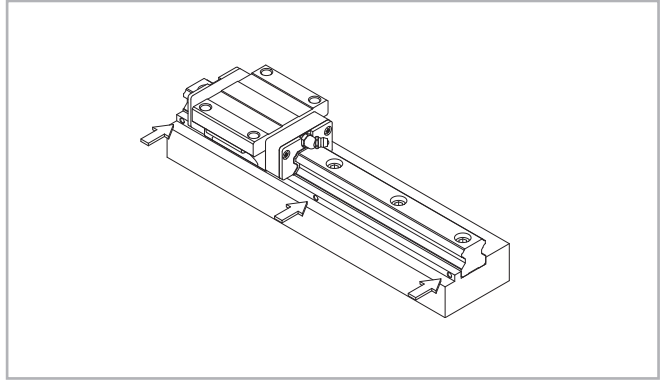

Fig. 58

(4) Tighten the fixing screws with a torque wrench to the prescribed torque (see pg. MR-37, tab. 39).

Note: For a high degree of accuracy, the fixing screws of the guide rail must be tightened in sequence outward from the centre (see fig. 59).

(5) Assemble the other rails in the same manner to complete the installation of the guide rails.

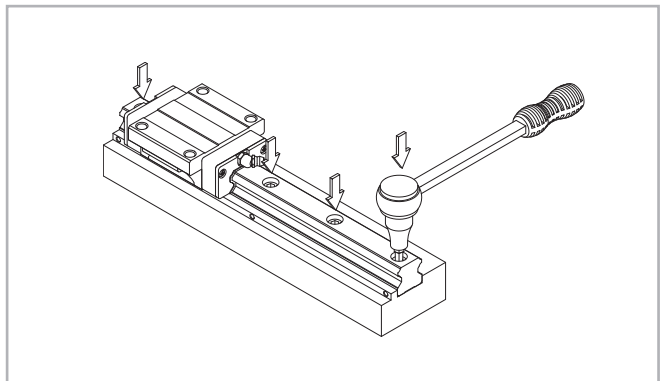

Fig. 59

Table assembly:

(6) Set the table carefully on the carriage and tighten the fixing screws only lightly.

(7) Press the carriage on the main guide side with the thrust bolts against the shoulder edge of the table and position the table.

(8) Tighten the fixing screws on the main side and the lateral side completely tight to finish the installation. Note:

To attach the table uniformly, tighten the fixing screws diagonally (see fig. 60). This method saves time when straightening the guide rail and makes the manufacture of positioning pins unnecessary, which considerably reduces assembly time.

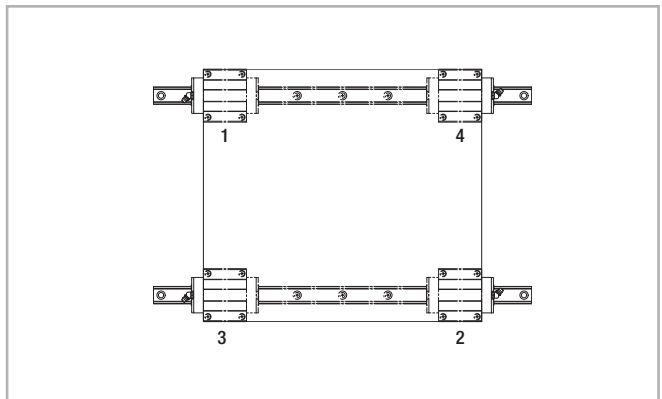

Fig. 60

> Installation examples

The following drawings illustrate some assembly examples for rail/carriage combinations corresponding to the structure of various machine frames:

Example 1:

Assembly of carriage and rail on shoulder edges

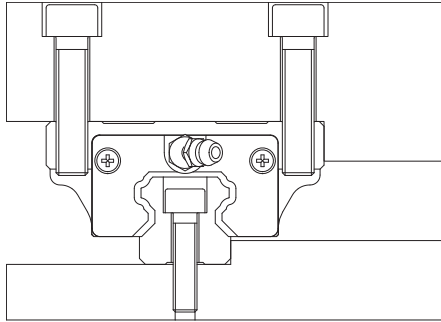

Example 2:

Securing carriage and rail using set screws

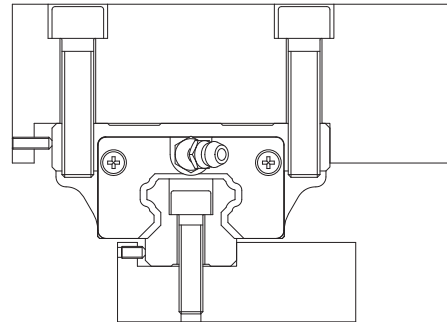

Example 3:

Securing carriage and rail using set pressure plates

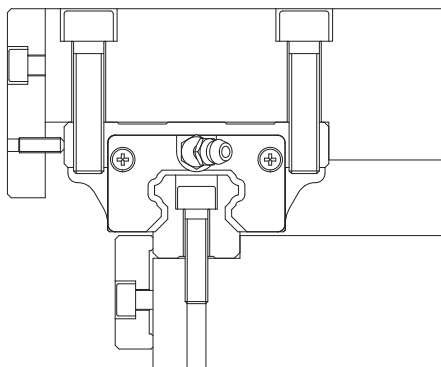

Example 4:

Securing carriage and rail using taper gibs

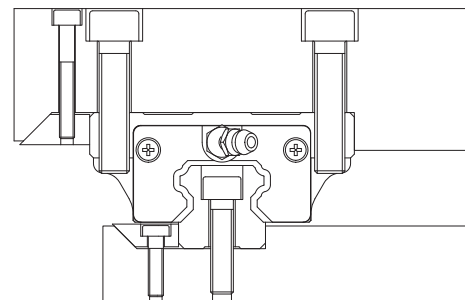

Example 5:

Securing carriage and rail using bolts

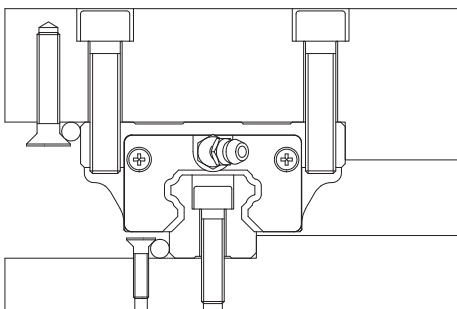

Fig. 61

Ordering key



> Rail / Mono Rail slider system

MRS30W	H	K1	A	1	05960	F	T	HC
								Surface coating for rail optional <i>see pg. MR-26, Anticorrosive protection</i>
								Joint processed rails optional <i>see pg. MR-40, Composite rails</i>
								Rails bolted from below, optional <i>see pg. MR-12</i>
								Total rail length
								Number of carriages
								Seal variants <i>see pg. MR-15f</i>
								Preload class <i>see pg. MR-24, tab. 25f</i>
								Precision class <i>see pg. MR-22, tab. 23</i>
Type								

Ordering example: MRS30W-H-K1-A-HC-1-05960F-T-HC

Rail composition: 1x3100+1x2860 (only for joint processed rails)

Hole pattern: 20-38x80-40//40-35x80-20 (please always indicate the hole pattern separately)

Notes on ordering: The rail lengths are always indicated as 5 digits with 0 prefixes

> Rail

MRR	20	6860	N	F	T	HC
						Surface coating for rail optional <i>see pg. MR-26, Anticorrosive protection</i>
						Joint processed rails optional <i>see pg. MR-40, Composite rails</i>
						Rails bolted from below, optional <i>see pg. MR-12</i>
						Precision class <i>see pg. MR-22, tab. 23</i>
						Total rail length
Size						
Rail type						

Ordering example: MRR20-06850-NF-T-HC

Rail composition: 1x2920+1x3940 (only for joint processed rails)

Hole pattern: 10-48x60-30//30-65x60-10 (please always specify the hole pattern separately)

Notes on ordering: The rail lengths are always indicated as 5 digits with 0 prefixes

> Carriage

MRS35	N	K0	A	HC	Surface coating for carriage optional <i>see pg. MR-26 Anticorrosive protection</i>
					Seal variants <i>see pg. MR-15f</i>
					Preload class <i>see pg. MR-24, tab. 25f</i>
					Precision class <i>see pg. MR-22, tab. 23</i>
				Type	

Ordering example: MRS35-N-K0-A-HC

> Rail / Miniature Mono Rail slider system

MR	15	M	N	SS	2	V1	P	310	Rail length <i>see tab. 46 and 47</i>
									Precision class <i>see pg. MR-23, tab. 24</i>
									Preload class <i>see pg. MR-25, tab. 27</i>
									Number of sliders on one rail
									End seal
									Slider type
									Rail type <i>see pg. MR-13, tab. 13 / pg. MR-14, tab. 15</i>
	Rail width <i>see pg. MR-13, tab. 13 / pg. MR-14, tab. 15</i>								
Product type									

Ordering example: MR15MN-SS-2-V1-P-310

Hole pattern: 15-7x40-15, see fig. 63, tab. 46 / fig. 64, tab. 47

> Mono Rail hole pattern

Rail

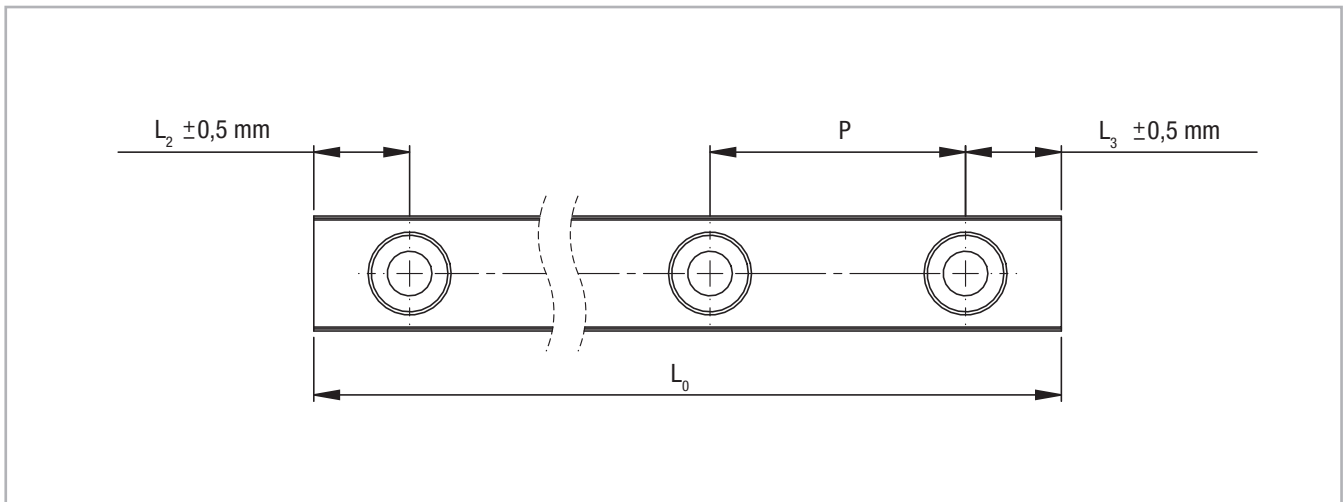

Fig. 62

Size	Hole pitch P [mm]	L_{2min}, L_{3min} [mm]	L_{2max}^*, L_{3max}^* [mm]	L_{0max} [mm]
15	60	7	20	4000
20				
25				
30	80	8.5	22.5	3960
35				
45	105	11.5	30	3930
55	120	13		3900

* Only applies when using max. rail lengths

Tab. 45

> Miniature Mono Rail hole pattern

Standard width

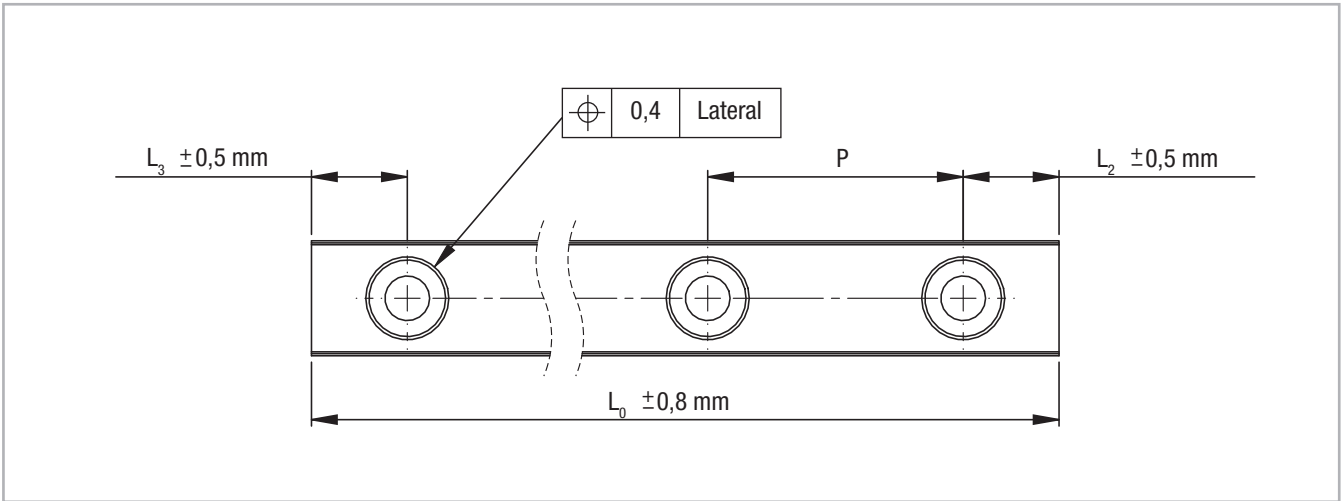

Fig. 63

Size	L_{min} [mm]	Hole pitch P [mm]	L_2, L_{3min} [mm]	L_2, L_{3max}^* [mm]	L_{max} [mm]
7	40	15	3	10	1000
9	55	20	4	15	
12	70	25	4	20	
15	70	40	4	35	

* does not apply to minimum (L_{min}) and maximum rail length (L_{max})

Tab. 46

Large width

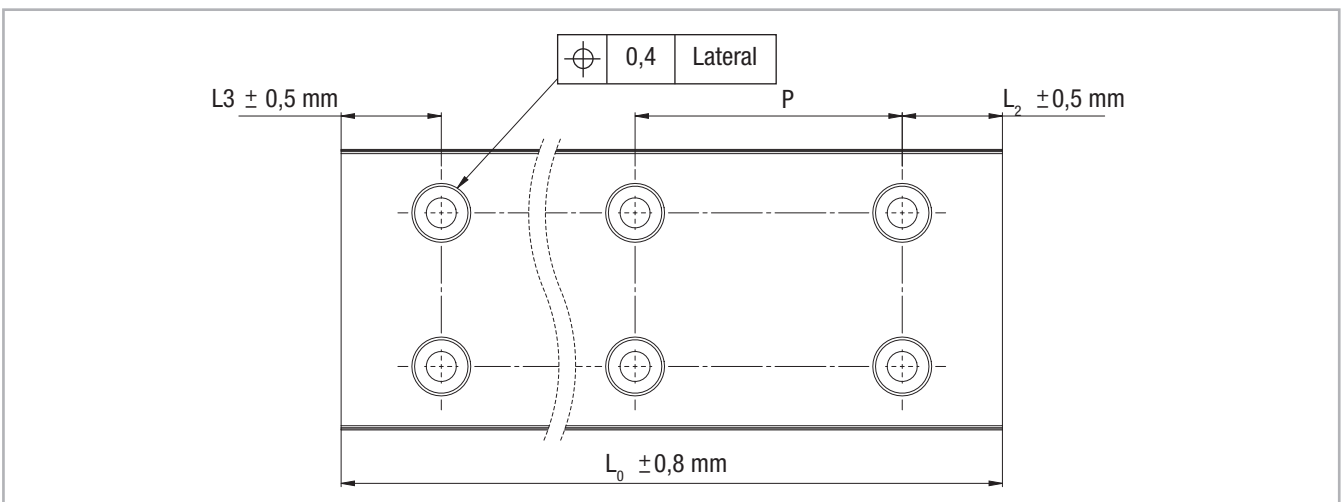

Fig. 64

Size	L_{min} [mm]	Hole pitch P [mm]	L_2, L_{3min} [mm]	L_2, L_{3max}^* [mm]	L_{max} [mm]
9	50	30	4	25	1000
12	70	40	5	35	
15	110	40		35	

* does not apply to minimum (L_{min}) and maximum rail length (L_{max})

Tab. 47