

CAST IRON SPUR GEARS

Z

MATERIAL: G20 CAST IRON - UNI 5007							
Module	2	2.5	3	3.5	4	4.5	5
Bores D_1	15	18	20	20	25	25	30
Surface B	20	25	30	35	40	45	50
30	dp				120	135	150
	de				128	144	160
	dm				70	70	80
35	dp			122.5	140	157.5	175
	de			129.5	148	166.5	185
	dm			60	70	70	80
40	dp			140	160	180	200
	de			147	168	189	210
	dm			60	70	70	80
45	dp	112.5	135	157.5	180	202.5	
	de	117.5	141	163.5	188	211.5	
	dm	50	50	60	70	70	
50	dp	100	125	175	200	225	250
	de	104	130	182	208	234	260
	dm	40	50	60	70	70	80
60	dp		180				
	de		186				
	dm		50				

Spur Gears

Pressure angle 20°

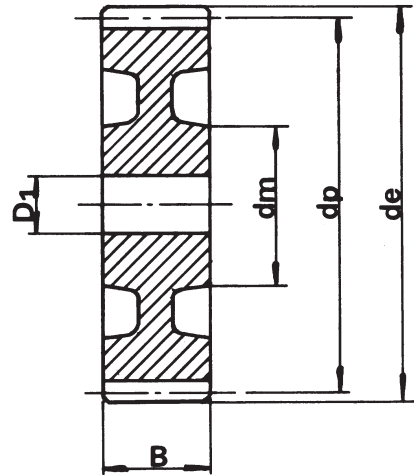

Gear till sold out

RACKS

MATERIAL: C40 - DRAWN - STANDARDISED					
Module	Dimensions b x h		h_0	L	kg.
	b	h			
1	15	15	14	500	0.820
	15	15	14	1000	1.640
	15	15	14	2000	3.200
1.5	17	17	15.5	500	1.000
	17	17	15.5	1000	2.050
	17	17	15.5	2000	4.000
2	20	20	18	500	1.410
	20	20	18	1000	2.750
	20	20	18	2000	5.500
2.5	25	25	22.5	500	2.100
	25	25	22.5	1000	4.500
	25	25	22.5	2000	9.000
3	30	30	27	500	3.100
	30	30	27	1000	6.500
	30	30	27	2000	13.000
4	30	30	26	500	3.050
	30	30	26	1000	6.100
	30	30	26	2000	12.500
4	40	40	36	500	5.500
	40	40	36	1000	11.000
	40	40	36	2000	23.000
5	50	50	45	500	8.300
	50	50	45	1000	17.500
	50	50	45	2000	35.000
6	60	60	54	500	12.650
	60	60	54	1000	25.500
	60	60	54	2000	51.000
10	80	80	70	2000	77.000

Racks

Pressure angle 20°

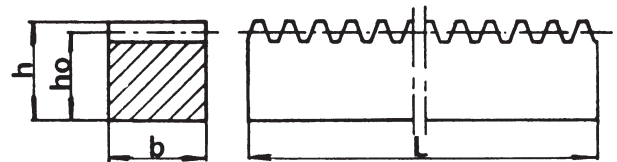

N.B. We manufacture racks from M7 to M16, on request.

STRAIGHT SPUR GEARS AND RACKS

Straight gears and racks are the classical components for mechanical transmission of rotary and transverse movements between moving parts of machines.

This explains why these components are so widespread and are used to such a large extent in various sectors of general mechanics such that in practice it is impossible to find a rigid type power transfer drive chain which does not adopt these basic components.

However, the needs of industry are extremely complex as regards the performance required from the gear and the rack and reflect the typical operating conditions in terms of precision or resistance of final use for which the gear and the rack are designed. This is why proposing a product intended to meet any need expressed by industrial experience would be unthinkable.

CHIARAVALLI Trasmissioni has made a basic choice with this aspect in mind, deciding to offer industry a broad range of gears and racks for general use, combined in a standardised series, which is characterised by excellent quality.

The gears and racks produced using standardised C40 steel are manufactured adopting modular sizes in accordance with a reference profile that complies with DIN 3972 II and a full head radius. This ensures complete engagement at the base of the tooth with an obvious increase in the bending resistance.

The internal specifications that define the geometry of the tooth prescribe a marked "K" profile for the side surface, with a strict limitation of the profile errors to negative deviations. This has a positive influence on the level of noise of the toothed pair, since the engaging impacts to the teeth head are reduced.

The systematic use of latest generation CNC gear hobbing machines, special hobs designed for very high cutting speeds and specifically developed processing technologies, enable a general precision to be assured in compliance with DIN 3962 Standards and a degree of surface finish that is not readily achieved with operations using a hob gear cutting machine.

The working tolerance for tooth thickness has been chosen to comply with the "cd 25" Coupling Category in accordance with DIN 3967 Standards, which defines the position and the size of the tolerance range and therefore the coupling gap between the gears.

A processing tolerance equal to "js 8" for the centre distance is recommended in compliance with DIN 3964 Standards for normal operating conditions, which if adopted, enables us to assure a minimum working coupling gap of adequate size, while at the same time limiting the value of the maximum gap. Similar considerations apply in the case of the gear-rack coupling, since the latter is manufactured adopting the same coupling cate-

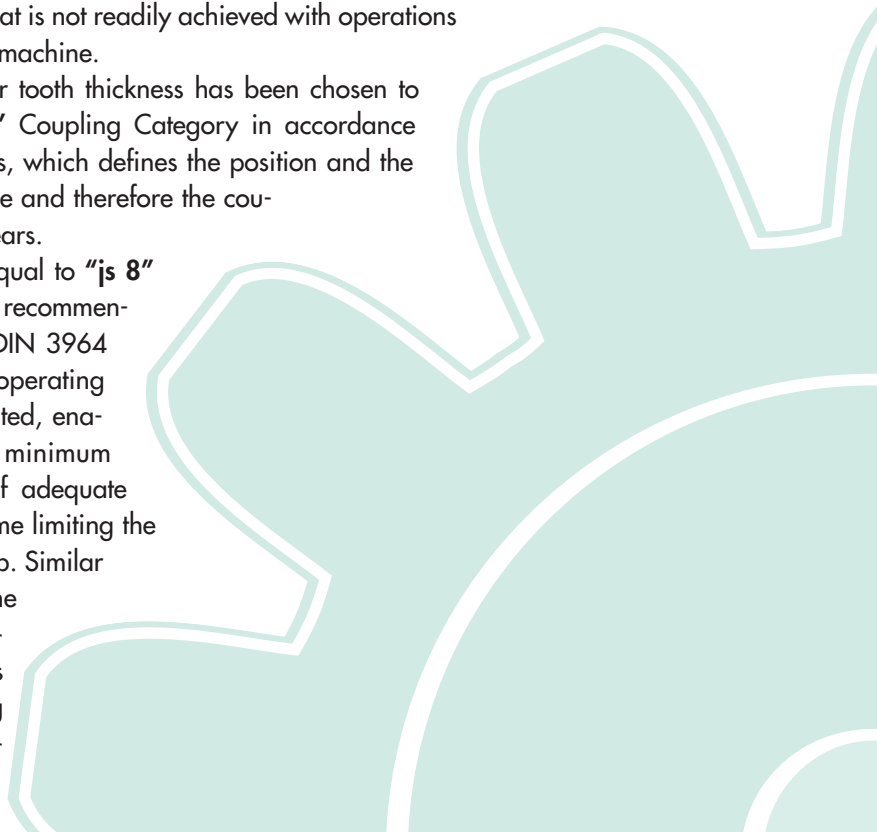

gory.

Our Technical Department is available and willing to recommend the most appropriate assembly tolerances to Customers who are interested, although we are also able to manufacture gears with coupling gaps that are larger or smaller compared with the standard value to meet specific needs.

We are able to manufacture our straight gears as illustrated in the catalogue with a lengthwise crowning of the teeth, at the request of customers. This solution is particularly useful if the user is unable to ensure a perfect alignment between the axles.

THE RANGE OF MACHINES USED, COMPRISING ALMOST ENTIRELY OF VERY MODERN MACHINES THAT HAVE CUTTING EDGE FEATURES AND DESIGN ENABLES OUR COMPANY TO PRODUCE GEARS BASED ON A DRAWING IN QUALITATIVE AT A VERY COMPETITIVE PRICE.

Our Technical Department is available to carry out a preliminary examination of any processing problems experienced by Customers and to prepare cost estimates.



STRAIGHT SPUR GEARS

HUBSIDE

Pressure angle 20°

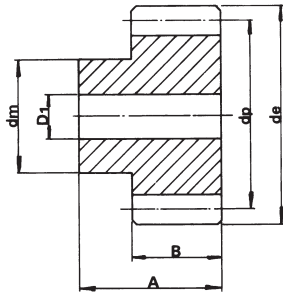

MATERIAL: C 45 – UNI 7845

TOOTH WIDTH "B" for:

MODULE 1	=	15 mm.
MODULE 1.5	=	17 mm.
MODULE 2	=	20 mm.
MODULE 2.5	=	25 mm.
MODULE 3	=	30 mm.
MODULE 4	=	40 mm.
MODULE 5	=	50 mm.
MODULE 6	=	60 mm.

TOTAL HEIGHT "A" for:

MODULE 1	=	25 mm.
MODULE 1.5	=	30 mm.
MODULE 2	=	35 mm.
MODULE 2.5	=	40 mm.
MODULE 3	=	50 mm.
MODULE 4	=	60 mm.
MODULE 5	=	75 mm.
MODULE 6	=	80 mm.

Z

12
13
14
15
16
17
18
19
20
21
22
23
24
25
26
27
28
29
30
31
32
33
34
35
36
37
38
39
40
41
42
43
44
45
46
47
48

Z	MODULE 3				MODULE 4				MODULE 5				MODULE 6			
	d _e	d _p	d _m	D ₁	d _e	d _p	d _m	D ₁	d _e	d _p	d _m	D ₁	d _e	d _p	d _m	D ₁
12	42	36	25	12	56	48	35	14	70	60	45	16	84	72	54	
13	45	39	25	12	60	52	40	14	75	65	50	16	90	78	60	
14	48	42	30	12	64	56	45	14	80	70	55	20				
15	51	45	35	12	68	60	45	14	85	75	60	20	102	90	70	
16	54	48	38	15	72	64	50	15	90	80	65	20	108	96	75	
17	57	51	42	15	76	68	50	15	95	85	70	20				
18	60	54	45	15	80	72	50	15	100	90	70	20	120	108	80	
19	63	57	45	15	84	76	60	15	105	95	70	20				
20	66	60	45	15	88	80	60	15	110	100	80	20	132	120	90	
21	69	63	45	15	92	84	70	20	115	105	80	20				
22	72	66	50	15	96	88	70	20	120	110	80	25				
23	75	69	50	15	100	92	75	20	125	115	90	25				
24	78	72	50	16	104	96	75	20	130	120	90	25	156	144	110	
25	81	75	60	16	108	100	75	20	135	125	90	25	162	150	110	
26	84	78	60	16	112	104	75	20	140	130	100	25				
27	87	81	60	16	116	108	75	20	145	135	100	25				
28	90	84	60	16	120	112	75	20	150	140	100	25				
29	93	87	60	16	124	116	75	20	155	145	100	25				
30	96	90	60	16	128	120	75	20	160	150	100	25				
31	99	93	70	20	132	124	80	20								
32	102	96	70	20	136	128	80	20								
33	105	99	70	20	140	132	80	20								
34	108	102	70	20	144	136	80	20								
35	111	105	70	20	148	140	80	20								
36	114	108	70	20	152	144	80	20								
37	117	111	80	20												
38	120	114	80	20												
39	123	117	80	20												
40	126	120	80	20												
41	129	123	90	20												
42	132	126	90	20												
43	135	129	90	20												
44	138	132	90	20												
45	141	135	90	20												
46	144	138	90	20												
47	147	141	90	20												
48	150	144	100	20												

STRAIGHT SPUR GEARS

HUBLESS

Pressure angle 20°

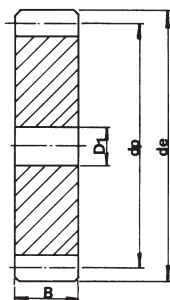

TOOTH WIDTH "B" for:

MODULE 1	=	15 mm.
MODULE 1.5	=	17 mm.
MODULE 2	=	20 mm.
MODULE 2.5	=	25 mm.
MODULE 3	=	30 mm.
MODULE 4	=	40 mm.
MODULE 5	=	50 mm.
MODULE 6	=	60 mm.

MATERIAL: C 45 – UNI 7845

Z

55
57
60
65
70
72
75
76
78
80
85
90
95
100
110
114
120
127

MODULE 1				MODULE 1.5				MODULE 2				MODULE 2.5			
d _e	d _p	d _m	D ₁	d _e	d _p	d _m	D ₁	d _e	d _p	d _m	D ₁	d _e	d _p	d _m	D ₁
												167.5	162.5		20
												180.0	175.0		20
74	72		12	111.0	108.0		20	148	144		20	185.0	180.0		20
77	75		12	115.5	112.5		20	154	150		20	192.5	187.5		20
78	76		12	117.0	114.0		20	156	152		20	195.0	190.0		20
82	80		12	123.0	120.0		20	164	160		20	205.0	200.0		25
87	85		12	130.5	127.5		20	174	170		20	217.5	212.5		25
92	90		12	138.0	135.0		20	184	180		20	230.0	225.0		25
97	95		12	145.5	142.5		20	194	190		20	242.5	237.5		25
102	100		12	153.0	150.0		20	204	200		20	255.0	250.0		25
112	110		12	168.0	165.0		20	224	220		20	280.0	275.0		25
116	114		12	174.0	171.0		20	232	228		20	290.0	285.0		25
122	120		12	183.0	180.0		20	244	240		20	305.0	300.0		25
129	127		12	193.5	190.5		20	258	254		20	322.5	317.5		25

Z

28
30
32
35
38
40
45
48
50
52
55
57
60
65
70
72
75
76
80
85
90
95
100
110
114
120
127

MODULE 3				MODULE 4				MODULE 5				MODULE 6			
d _e	d _p	d _m	D ₁	d _e	d _p	d _m	D ₁	d _e	d _p	d _m	D ₁	d _e	d _p	d _m	D ₁
												180	168		25
												192	180		25
								170	160		25	204	192		25
				160	152		25	185	175		25	222	210		25
				168	160		25	200	190		30	240	228		25
				188	180		25	210	200		30	252	240		25
				200	192		25	235	225		30				
				208	200		25	250	240		30				
156	150		25	208	200		25	260	250		30				
162	156		25	216	208		25	270	260		30				
171	165		25	228	220		25	285	275		30				
177	171		25	236	228		25	295	285		30				
186	180		25	248	240		25	310	300		30				
201	195		25	268	260		25	335	325		30				
216	210		25	288	280		25	360	350		30				
222	216		25												
231	225		25	308	300		25	385	375		30				
234	228		25	312	304		25	390	380		30				
246	240		25	328	320		25	410	400		30				
261	255		25	348	340		25	435	425		30				
276	270		25	368	360		25	460	450		30				
291	285		25	388	380		25	485	475		30				
306	300		25	408	400		25	510	500		30				
336	330		25	448	440		25	560	550		30				
348	342		25	464	456		25	580	570		30				
366	360		25												
387	381		25												

CAST IRON SPUR GEARS

		MATERIAL: G20 CAST IRON – UNI 5007						
Z	Module	2	2.5	3	3.5	4	4.5	5
	Bores D_1	15	18	20	20	25	25	30
	Surface B	20	25	30	35	40	45	50
30	dp					120	135	150
	de					128	144	160
	dm					70	70	80
35	dp				122.5	140	157.5	175
	de				129.5	148	166.5	185
	dm				60	70	70	80
40	dp				140	160	180	200
	de				147	168	189	210
	dm				60	70	70	80
45	dp		112.5	135	157.5	180	202.5	
	de		117.5	141	163.5	188	211.5	
	dm		50	50	60	70	70	
50	dp	100	125		175	200	225	250
	de	104	130		182	208	234	260
	dm	40	50		60	70	70	80
60	dp			180				
	de			186				
	dm			50				

Spur Gears

Pressure angle 20°

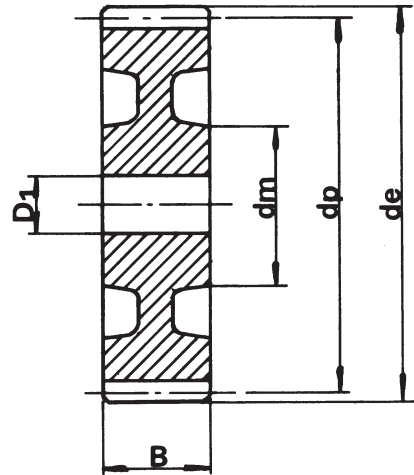

Gear till sold out

RACKS

		MATERIAL: C40 - DRAWN - STANDARDISED				
Module	Dimensions b x h		h_0	L	kg.	
	b	h				
1	15	15	14	500	0.820	
	15	15	14	1000	1.640	
	15	15	14	2000	3.200	
1.5	17	17	15.5	500	1.000	
	17	17	15.5	1000	2.050	
	17	17	15.5	2000	4.000	
2	20	20	18	500	1.410	
	20	20	18	1000	2.750	
	20	20	18	2000	5.500	
2.5	25	25	22.5	500	2.100	
	25	25	22.5	1000	4.500	
	25	25	22.5	2000	9.000	
3	30	30	27	500	3.100	
	30	30	27	1000	6.500	
	30	30	27	2000	13.000	
4	30	30	26	500	3.050	
	30	30	26	1000	6.100	
	30	30	26	2000	12.500	
4	40	40	36	500	5.500	
	40	40	36	1000	11.000	
	40	40	36	2000	23.000	
5	50	50	45	500	8.300	
	50	50	45	1000	17.500	
	50	50	45	2000	35.000	
6	60	60	54	500	12.650	
	60	60	54	1000	25.500	
	60	60	54	2000	51.000	
10	80	80	70	2000	77.000	

Racks

Pressure angle 20°

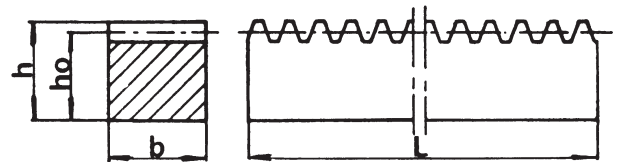

N.B. We manufacture racks from M7 to M16, on request.