

DOUBLE / SINGLE PLATEWHEELS

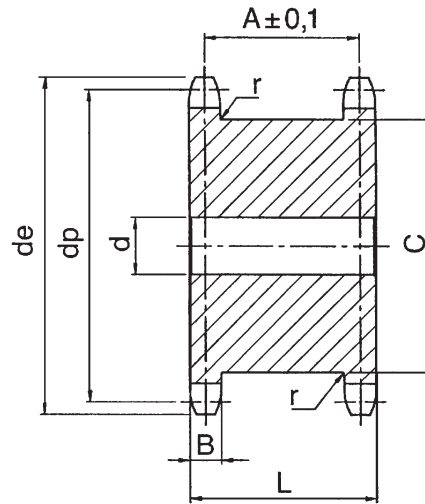

Material / C45 UNI 7845

TYPE	Z	OUTSIDE De	PITCH Dp	d	A	B h14	C max	L	r
3/8"x7/32" R. 6.35 06 B-1	13	43.45	39.80	10	20.3	5.3	28	25.5	0.4
	15	49.46	45.81	10	20.3	5.3	34	25.5	0.4
	17	55.49	51.84	12	20.3	5.3	40	25.5	0.4
	18	58.30	54.85	12	20.3	5.3	43	25.5	0.4
	19	61.52	57.87	12	20.3	5.3	46	25.5	0.4
	20	64.30	60.89	12	20.3	5.3	49	25.5	0.4
	21	67.56	63.91	15	20.3	5.3	52	25.5	0.4
	23	73.60	69.95	15	20.3	5.3	59	25.5	0.4
25	79.65	76.00	15	20.3	5.3	65	25.5	0.4	
1/2"x5/16" R. 8.51 08 B-1	13	57.56	53.07	12	24.8	7.2	37	32	0.6
	15	65.57	61.08	12	24.8	7.2	45	32	0.6
	17	73.61	69.12	12	24.8	7.2	53	32	0.6
	18	78.00	73.14	12	24.8	7.2	57	32	0.6
	19	81.65	77.16	12	24.8	7.2	62	32	0.6
	20	86.00	81.19	12	24.8	7.2	65	32	0.6
	21	89.70	85.21	15	24.8	7.2	70	32	0.6
	23	97.76	93.27	15	24.8	7.2	78	32	0.6
25	105.82	101.33	15	24.8	7.2	86	32	0.6	
5/8"x3/8" R. 10.16 10 B-1	13	73.17	66.33	15	27.9	9.1	48	37	0.6
	15	83.19	76.35	15	27.9	9.1	58	37	0.6
	17	93.23	86.39	15	27.9	9.1	68	37	0.6
	18	98.30	91.42	15	27.9	9.1	72	37	0.6
	19	103.29	96.45	15	27.9	9.1	79	37	0.6
	20	108.40	101.49	19	27.9	9.1	82	37	0.6
	21	113.35	106.51	19	27.9	9.1	89	37	0.6
	23	123.43	116.59	19	27.9	9.1	99	37	0.6
25	133.50	126.66	19	27.9	9.1	109	37	0.6	
3/4"x7/16" R. 12.07 12 B-1	13	87.13	76.90	20	33.9	11.1	59	45	0.6
	15	99.16	91.63	20	33.9	11.1	71	45	0.6
	17	111.20	103.67	20	33.9	11.1	83	45	0.6
	18	118.00	109.71	20	33.9	11.1	88	45	0.6
	19	123.27	115.74	20	33.9	11.1	95	45	0.6
	20	129.70	121.78	20	33.9	11.1	101	45	0.6
	21	135.35	127.82	20	33.9	11.1	107	45	0.6
	23	147.43	139.90	20	33.9	11.1	119	45	0.6
25	159.52	151.99	24	33.9	11.1	131	45	0.6	
1"x17.02 R. 15.88 16 B-1	13	117.26	106.14	24	47.8	16.2	78	64	0.8
	15	133.29	122.17	24	47.8	16.2	95	64	0.8
	17	149.35	138.23	24	47.8	16.2	111	64	0.8
	18	157.00	146.28	24	47.8	16.2	119	64	0.8
	19	165.44	154.32	24	47.8	16.2	127	64	0.8
	20	173.00	162.38	24	47.8	16.2	135	64	0.8
	21	181.54	170.42	24	47.8	16.2	143	64	0.8
	23	197.66	186.54	24	47.8	16.2	160	64	0.8
25	213.78	202.66	24	47.8	16.2	176	64	0.8	

SINGLE STAINLESS STEEL SPROCKETS

For roller chains in compliance with DIN 8187 – ISO/R 606

PITCH	Z	12	13	15	16	17	18	19	20	21	23	25	30
	3/8" x 7/32"	de	-	43.00	49.30	52.30	55.30	58.30	61.30	64.30	68.00	73.50	80.00
dp		-	39.79	45.81	48.82	51.83	54.85	57.87	60.89	63.91	69.65	76.00	91.12
dm		-	28.00	34.00	37.00	40.00	43.00	45.00	46.00	48.00	52.00	57.00	60.00
D1		-	10.00	10.00	10.00	10.00	10.00	10.00	10.00	10.00	12.00	12.00	12.00
A		-	25.00	25.00	28.00	28.00	28.00	28.00	28.00	28.00	28.00	28.00	30.00
1/2" x 5/16"	de	53.00	57.90	65.90	69.90	74.00	78.00	82.00	86.00	90.01	98.01	106.20	126.30
	dp	49.07	53.06	61.09	65.10	69.11	73.14	77.16	81.19	85.22	93.27	101.33	121.50
	dm	33.00	37.00	45.00	50.00	52.00	56.00	60.00	64.00	68.00	70.00	70.00	80.00
	D1	10.00	10.00	10.00	12.00	12.00	12.00	12.00	12.00	14.00	14.00	14.00	16.00
	A	28.00	28.00	28.00	28.00	28.00	28.00	28.00	28.00	28.00	28.00	28.00	30.00
5/8" x 3/8"	de	-	73.00	83.00	88.00	93.00	98.30	103.30	108.40	113.40	123.40	134.00	158.80
	dp	-	66.32	76.36	81.37	86.39	91.42	96.45	101.49	106.52	116.58	126.66	151.87
	dm	-	47.00	57.00	60.00	60.00	70.00	70.00	75.00	80.00	80.00	80.00	90.00
	D1	-	12.00	12.00	12.00	12.00	12.00	14.00	14.00	16.00	16.00	16.00	20.00
	A	-	30.00	30.00	30.00	30.00	30.00	30.00	30.00	30.00	30.00	30.00	35.00
3/4" x 7/16"	de	-	87.50	99.80	105.50	111.50	118.00	124.20	129.70	136.00	149.00	160.00	-
	dp	-	79.59	91.63	97.65	103.67	109.71	115.75	121.78	127.82	139.90	152.00	-
	dm	-	58.00	70.00	75.00	80.00	80.00	80.00	80.00	90.00	90.00	90.00	-
	D1	-	16.00	16.00	16.00	16.00	16.00	16.00	16.00	20.00	20.00	20.00	-
	A	-	35.00	35.00	35.00	35.00	35.00	35.00	35.00	40.00	40.00	40.00	-
1" x 17.02	de	-	117.00	133.00	141.00	149.00	157.00	165.20	163.00	181.20	-	-	-
	dp	-	106.12	122.17	130.20	138.22	146.28	154.33	162.38	170.43	-	-	-
	dm	-	78.00	92.00	100.00	100.00	100.00	100.00	100.00	110.00	-	-	-
	D1	-	16.00	16.00	19.00	20.00	20.00	20.00	20.00	20.00	-	-	-
	A	-	40.00	40.00	45.00	45.00	45.00	45.00	45.00	50.00	-	-	-

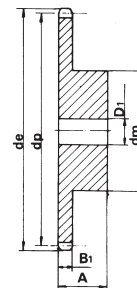

MATERIAL:
AISI 304 L
STAINLESS STEEL

SINGLE SPROCKETS WITH INDUCTION HARDENED TEETH

PITCH	Z	13	14	15	16	17	18	19	20	21	23	25	27	30
	3/8" x 7/32"	de	43.00	46.50	49.30	52.30	55.30	58.30	61.30	64.30	68.00	73.50	80.00	86.00
dp		39.79	42.80	45.81	48.82	51.83	54.85	57.87	60.89	63.91	69.95	76.00	82.05	91.12
dm		28.00	31.00	34.00	37.00	40.00	43.00	45.00	46.00	48.00	52.00	57.00	60.00	60.00
D1		10.00	10.00	10.00	10.00	10.00	10.00	10.00	10.00	10.00	12.00	12.00	12.00	12.00
A		25.00	25.00	25.00	28.00	28.00	28.00	28.00	28.00	28.00	28.00	28.00	28.00	30.00
1/2" x 5/16"	de	57.40	61.80	65.90	69.90	74.00	78.00	82.00	86.00	90.10	98.10	106.20	114.00	126.30
	dp	53.60	57.07	61.09	65.10	69.11	73.14	77.16	81.19	85.22	93.27	101.33	109.40	121.50
	dm	37.00	41.00	45.00	50.00	52.00	56.00	60.00	64.00	68.00	70.00	70.00	70.00	80.00
	D1	10.00	10.00	10.00	12.00	12.00	12.00	12.00	12.00	14.00	14.00	14.00	16.00	16.00
	A	28.00	28.00	28.00	28.00	28.00	28.00	28.00	28.00	28.00	28.00	28.00	30.00	30.00
5/8" x 3/8"	de	73.00	76.20	83.00	88.00	93.00	98.30	103.30	108.40	113.40	123.40	134.00	143.50	158.70
	dp	66.32	71.34	76.36	81.37	86.39	91.42	96.45	101.49	106.52	116.58	126.66	136.74	151.87
	dm	47.00	52.00	57.00	60.00	60.00	70.00	70.00	75.00	80.00	80.00	80.00	80.00	90.00
	D1	12.00	12.00	12.00	12.00	12.00	12.00	14.00	14.00	16.00	16.00	16.00	16.00	20.00
	A	30.00	30.00	30.00	30.00	30.00	30.00	30.00	30.00	30.00	30.00	30.00	30.00	35.00
3/4" x 7/16"	de	87.50	93.80	99.80	105.50	111.50	118.00	124.20	129.70	136.00	149.00	160.00	171.60	189.80
	dp	79.59	85.61	91.63	97.65	103.67	109.71	115.75	121.78	127.82	139.90	152.00	164.09	182.25
	dm	58.00	64.00	70.00	75.00	80.00	80.00	80.00	80.00	90.00	90.00	90.00	90.00	95.00
	D1	14.00	16.00	16.00	16.00	16.00	16.00	16.00	16.00	20.00	20.00	20.00	20.00	20.00
	A	35.00	35.00	35.00	35.00	35.00	35.00	35.00	35.00	40.00	40.00	40.00	40.00	40.00
1" x 17.02	de	117.00	125.70	133.00	141.00	149.00	157.00	165.20	173.00	181.20	197.60	213.70	229.60	254.60
	dp	106.12	114.15	122.17	130.20	138.22	146.28	154.33	162.38	170.43	186.54	202.66	218.79	243.00
	dm	78.00	84.00	92.00	100.00	100.00	100.00	100.00	100.00	110.00	110.00	110.00	110.00	120.00
	D1	16.00	16.00	16.00	19.00	20.00	20.00	20.00	20.00	20.00	20.00	20.00	20.00	20.00
	A	40.00	40.00	40.00	45.00	45.00	45.00	45.00	45.00	50.00	50.00	50.00	50.00	50.00

Induction hardened teeth
HRC 45÷53

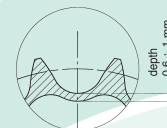

MATERIAL:
C45 UNI7845

SINGLE SPROCKETS WITH INDUCTION HARDENED TEETH WITH BORE + KEYWAY + SETSCREW HOLES

3/8" x 7/32" 06B-1

for roller chains in compliance with DIN 8187 ISO/R 606

z	d _e	d _p	d _m	A	D ₁	z	d _e	d _p	d _m	A	D ₁	z	d _e	d _p	d _m	A	D ₁
13	43.5	39.80	28	25	12 14 15 16 18	18	58.3	54.85	43	28	14 15 16 18 19 20 22 24	23	73.7	69.95	52	28	15 16 18 19 20 22 24 25
14	46.5	42.80	31	25	12 14 15 16 18	19	61.6	57.87	45	28	15 16 18 19 20 22 24	24	76.7	72.97	54	28	18 19 20 22 24 25
15	49.5	45.81	34	25	14 15 16 18 19 20 22 24	20	64.3	60.89	46	28	15 16 18 19 20 22 24	25	79.7	76.00	57	28	18 20 22 24 25
16	52.3	48.82	37	28	14 15 16 18 19 20 22 24	21	67.6	63.91	48	28	15 16 18 19 20 22 24	27	85.7	82.05	60	28	20 22 24 25
17	55.5	51.83	40	28	14 15 16 18 19 20 22 24							30	94.8	91.12	60	30	20 22 24 25

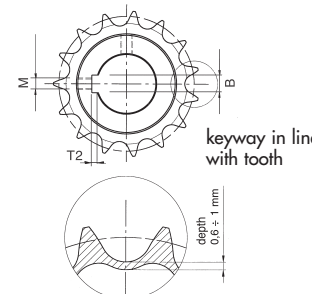
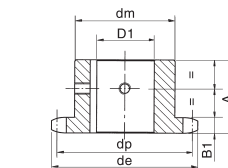

Induction hardened teeth HRC 45±53

SPROCKET mm

SPROCKET TOOTH WIDTH B₁ 5.3

CHAIN mm

PITCH 9.525
INNER WIDTH 5.72
ROLLER - ∅ 6.35

MATERIAL: C 45 UNI 7845

z	d _e	d _p	d _m	A	D ₁	z	d _e	d _p	d _m	A	D ₁	z	d _e	d _p	d _m	A	D ₁
12	53.9	49.07	33	28	12 14 15 16 18 19 20	17	74	69.11	52	28	15 16 18 19 20 22 24 25 28 30	23	98.1	93.27	70	28	20 22 24 25 28 30 32 35 38
13	57.9	53.06	37	28	12 14 15 16 18 19 20 22 24	18	77.8	73.14	56	28	16 18 19 20 22 24 25 28 30	24	102.1	97.29	70	28	20 22 24 25 28 30 32 35 38
14	61.6	57.07	41	28	14 15 16 18 19 20 22 24 25	19	82	77.16	60	28	19 20 22 24 25 28 30 32 35	25	105.8	101.33	70	28	20 22 24 25 28 30 32 35 38
15	65.9	61.09	45	28	14 15 16 18 19 20 22 24 25	20	85.8	81.19	64	28	19 20 22 24 25 28 30 32 35	27	114	109.4	70	30	22 25 28 30 32 35 38
16	69.5	65.1	50	28	15 16 18 19 20 22 24 25	21	90.1	85.22	68	28	19 20 22 24 25 28 30 32 35	30	126.3	121.5	80	30	25 28 30 32 35 38

1/2" x 5/16" 08B-1

for roller chains in compliance with DIN 8187 ISO/R 606

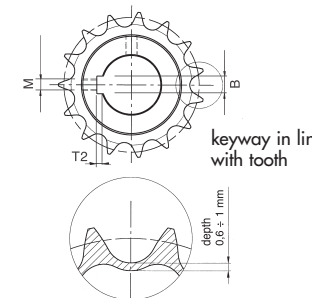
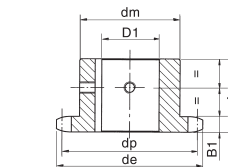

Induction hardened teeth HRC 45±53

SPROCKET mm

SPROCKET TOOTH WIDTH B₁ 7.2

CHAIN mm

PITCH 12.7
INNER WIDTH 7.75
ROLLER - ∅ 8.51

MATERIAL: C 45 UNI 7845

SINGLE SPROCKETS WITH INDUCTION HARDENED TEETH WITH BORE + KEYWAY + SETSCREW HOLES

z	d _e	d _p	d _m	A	D ₁	z	d _e	d _p	d _m	A	D ₁	z	d _e	d _p	d _m	A	D ₁
12	109.71	98.14	69	40	25	16	141.0	130.20	100	45	30	20	173.2	162.38	100	45	30
					28						32						32
					30						35						35
					32						38						38
					35						40						40
					38						42						42
					40						45						45
					42						48						48
					45						50						50
13	117.2	106.14	78	40	25	17	149.4	138.22	100	45	30	21	181.6	170.43	110	50	30
					28						32						32
					30						35						35
					32						38						38
					35						40						40
					38						42						42
					40						45						45
					42						48						48
					45						50						50
14	125.7	114.15	84	40	25	18	157.0	146.28	100	45	30	23	198.1	186.1	110	50	30
					28						32						32
					30						35						35
					32						38						38
					35						40						40
					38						42						42
					40						45						45
					42						48						48
					45						50						50
15	133.3	122.17	92	40	28	19	165.5	154.33	100	45	30	25	214.2	202.66	110	50	30
					30						32						32
					32						35						35
					35						38						38
					38						40						40
					40						42						42
					42						45						45
					45						48						48
					48						50						50

1" x 17.02 16B-1

for roller chains in compliance with DIN 8187 ISO/R 606

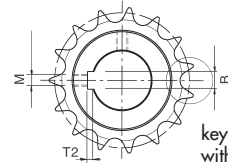
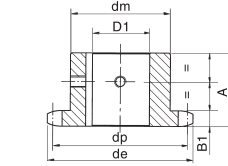

keyway in line with tooth

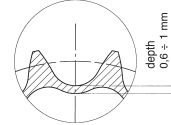

Induction hardened teeth HRC 45-53

SPROCKET mm

SPROCKET TOOTH WIDTH B₁ 16.2

CHAIN mm

PITCH 25.4

INNER WIDTH 17.02

ROLLER - Ø 15.88

MATERIAL: C 45 UNI 7845

KEYWAY TO DIN 6885 - JS9

D ₁ Bore	B Keyway Width	T ₂ Keyway Depth	M Screws
Ø 12 H7 ^{+0.018} / ₋₀	4 H9 ^{+0.030} / ₋₀	1,8 ^{+0.10} / ₋₀	M4
Ø 14 H7 ^{+0.018} / ₋₀	5 H9 ^{+0.030} / ₋₀	2,3 ^{+0.10} / ₋₀	M4
Ø 15 H7 ^{+0.018} / ₋₀	5 H9 ^{+0.030} / ₋₀	2,3 ^{+0.10} / ₋₀	M4
Ø 16 H7 ^{+0.018} / ₋₀	5 H9 ^{+0.030} / ₋₀	2,3 ^{+0.10} / ₋₀	M4
Ø 18 H7 ^{+0.018} / ₋₀	6 H9 ^{+0.030} / ₋₀	2,8 ^{+0.10} / ₋₀	M5
Ø 19 H7 ^{+0.021} / ₋₀	6 H9 ^{+0.030} / ₋₀	2,8 ^{+0.10} / ₋₀	M5
Ø 20 H7 ^{+0.021} / ₋₀	6 H9 ^{+0.030} / ₋₀	2,8 ^{+0.10} / ₋₀	M5
Ø 22 H7 ^{+0.021} / ₋₀	6 H9 ^{+0.030} / ₋₀	2,8 ^{+0.10} / ₋₀	M5
Ø 24 H7 ^{+0.021} / ₋₀	8 H9 ^{+0.036} / ₋₀	3,3 ^{+0.20} / ₋₀	M6
Ø 25 H7 ^{+0.021} / ₋₀	8 H9 ^{+0.036} / ₋₀	3,3 ^{+0.20} / ₋₀	M6
Ø 28 H7 ^{+0.021} / ₋₀	8 H9 ^{+0.036} / ₋₀	3,3 ^{+0.20} / ₋₀	M6
Ø 30 H7 ^{+0.021} / ₋₀	8 H9 ^{+0.036} / ₋₀	3,3 ^{+0.20} / ₋₀	M6
Ø 32 H7 ^{+0.025} / ₋₀	10 H9 ^{+0.036} / ₋₀	3,3 ^{+0.20} / ₋₀	M8
Ø 35 H7 ^{+0.025} / ₋₀	10 H9 ^{+0.036} / ₋₀	3,3 ^{+0.20} / ₋₀	M8
Ø 38 H7 ^{+0.025} / ₋₀	10 H9 ^{+0.036} / ₋₀	3,3 ^{+0.20} / ₋₀	M8
Ø 40 H7 ^{+0.025} / ₋₀	12 H9 ^{+0.043} / ₋₀	3,3 ^{+0.20} / ₋₀	M10
Ø 42 H7 ^{+0.025} / ₋₀	12 H9 ^{+0.043} / ₋₀	3,3 ^{+0.20} / ₋₀	M10
Ø 45 H7 ^{+0.025} / ₋₀	14 H9 ^{+0.043} / ₋₀	3,8 ^{+0.20} / ₋₀	M12
Ø 48 H7 ^{+0.025} / ₋₀	14 H9 ^{+0.043} / ₋₀	3,8 ^{+0.20} / ₋₀	M12
Ø 50 H7 ^{+0.025} / ₋₀	14 H9 ^{+0.043} / ₋₀	3,8 ^{+0.20} / ₋₀	M12

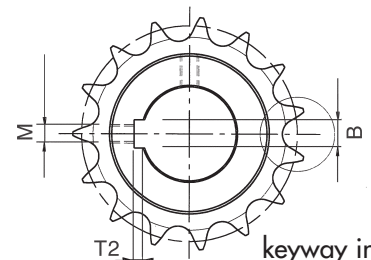
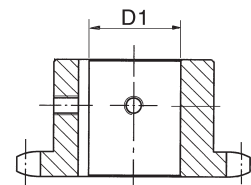

keyway in line with tooth

SPROCKETS

Z	d _e	d _p	SINGLE			DOUBLE			d _m	D ₁	A
			d _m	D ₁	A	d _m	D ₁	A			
10	35.70	30.82	20	8	22						
11	38.69	33.80	22	8	25						
12	41.68	36.80	25	8	25						
13	44.68	39.80	28	10	25	28	10	25			
14	47.68	42.80	31	10	25	31	10	25			
15	50.69	45.81	34	10	25	34	10	25			
16	53.70	48.82	37	10	28	37	12	30			
17	56.72	51.83	38	10	28	40	12	30			
18	59.73	54.85	38	10	28	43	12	30			
19	62.75	57.87	46	10	28	46	12	30			
20	65.77	60.89	46	10	28	49	12	30			
21	68.79	63.91	46	10	28	52	12	30			
22	71.81	66.93	52	12	28	55	12	30			
23	74.83	69.95	52	12	28	58	12	30			
24	77.85	72.97	52	12	28	61	12	30			
25	80.88	76.00	58	12	28	64	12	30			
26	83.90	79.02	58	12	28	67	12	30			
27	86.93	82.04	58	12	28	70	12	30			
28	89.95	85.07	60	12	28	73	12	30			
30	96.00	91.12	60	12	28						

PLATEWHEELS

Z	d _e	d _p	S			D			T		
			D ₁	D ₂	D ₃						
30	96.00	91.12									
32	102.06	97.17	12								
36	114.17	109.29	12								
38	120.22	115.34	12	14							
40	126.28	121.40	12								
45	141.43	136.55	16	16							
48	150.52	145.64	16								
57	177.79	172.91	16	16							
76	235.37	230.49	20	20							

SPROCKETS

Z	d _e	d _p	SINGLE			DOUBLE			TRIPLE		
			d _m	D ₁	A	d _m	D ₁	A	d _m	D ₁	A
10	47.66	41.10	26	10	25						
11	51.64	45.08	29	10	25						
12	55.63	49.07	35	10	28						
13	59.63	53.07	35	10	28	38	12	35	38	14	50
14	63.63	57.07	35	10	28	42	12	35	42	14	50
15	67.64	61.08	46	10	28	46	12	35	46	14	50
16	71.66	65.10	48	10	28	50	14	35	50	16	50
17	75.68	69.12	48	10	28	54	14	35	54	16	50
18	79.70	73.14	58	12	28	58	14	35	58	16	50
19	83.72	77.16	60	12	28	62	14	35	62	16	50
20	87.74	81.18	60	12	28	66	14	35	66	16	50
21	91.77	85.21	65	12	28	70	16	40	70	20	55
22	95.80	89.24	65	12	28	70	16	40	70	20	55
23	99.83	93.27	65	12	28	70	16	40	70	20	55
24	103.86	97.30	70	14	28	75	16	40	75	20	55
25	107.89	101.33	70	14	28	80	16	40	80	20	55
26	111.92	105.36	70	14	28	85	20	40	85	20	55
27	115.96	109.40	70	16	30	85	20	40	85	20	55
28	119.99	113.43	70	16	30	90	20	40	90	20	55
30	128.06	121.50	80	16	30	100	20	40			
32	136.13	129.57	80	16	30						
35	148.24	141.68	90	16	30						
36	152.28	145.72	90	16	30						
38	160.35	153.79	90	16	35						
40	168.43	161.87	90	16	35						

PLATEWHEELS

Z	d _e	d _p	S			D			T		
			D ₁	D ₂	D ₃						
30	128.06	121.50									
32	136.13	129.57									
38	160.35	153.79									
40	168.43	161.87									
42	176.50	169.94	20								
45	188.62	182.06	20	20	25						
48	200.74	194.18	20								
57	237.10	230.54	20	25	25						
76	313.88	307.32	25	25	25						
95	390.67	384.11	25								

Pitch 3/8" x 3/16"

for roller chains in compliance with
DIN 8188-ISO/R 606 - ANSI B 29.1

SPROCKET

TOOTH RADIUS r ₃	10
RADIUS WIDTH C	1.2
SPROCKET TOOTH WIDTH B ₁	4.4
SPROCKET TOOTH WIDTH b ₁	4.3
SPROCKET TOOTH WIDTH B ₂	14.4

CHAIN

PITCH	9.525
INNER WIDTH	4.77
ROLLER - ø	5.08

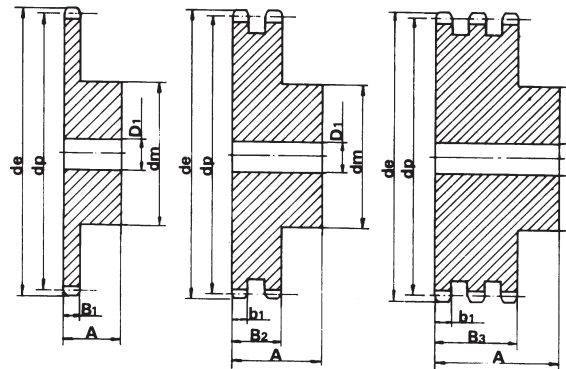

MATERIAL: C 45 UNI 7845 SPROCKETS

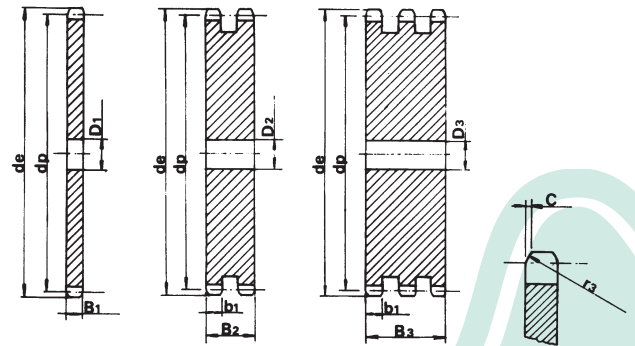

Pitch 1/2" x 5/16"

for roller chains in compliance with
DIN 8188-ISO/R 606 - ANSI B 29.1

CORONA

TOOTH RADIUS r ₃	13.5
RADIUS WIDTH C	1.6
PLATE TOOTH WIDTH B ₁	7.4
PLATE TOOTH WIDTH b ₁	7.2
PLATE TOOTH WIDTH B ₂	21.6
PLATE TOOTH WIDTH B ₃	36

CATENA

PITCH	12.7
INNER WIDTH	7.94
ROLLER - ø	7.94

MATERIAL C 45 UNI 7845 SPROCKETS

S P R O C K E T S

ASA 50

Z	d _e	d _p	SINGLE			DOUBLE			TRIPLE		
			d _m	D ₁	A	d _m	D ₁	A	d _m	D ₁	A
8	47.0	41.48	25	10	25						
9	52.6	46.42	30	10	25						
10	57.5	51.37	35	10	25						
11	63.0	56.34	37	12	30						
12	68.0	61.34	42	12	30				44	16	55
13	73.0	66.32	47	12	30	49	14	40	49	16	55
14	78.0	71.34	52	12	30	54	14	40	54	16	55
15	83.0	76.36	57	12	30	59	14	40	59	16	55
16	88.0	81.37	60	12	30	64	16	45	64	16	60
17	93.0	86.39	60	12	30	69	16	45	69	16	60
18	98.3	91.42	70	14	30	74	16	45	74	16	60
19	103.3	96.45	70	14	30	79	16	45	79	16	60
20	108.4	101.49	75	14	30	84	16	45	84	16	60
21	113.4	106.52	75	16	30	85	16	45	85	20	60
22	118.0	111.55	80	16	30	90	16	45	90	20	60
23	123.4	116.58	80	16	30	95	16	45	95	20	60
24	128.3	121.62	80	16	30	100	16	45	100	20	60
25	134.0	126.66	80	16	30	105	16	45	105	20	60
26	139.0	131.70	85	20	35				110	20	60
27	144.0	136.75	85	20	35				110	20	60
28	148.7	141.78	90	20	35				115	20	60
29	153.8	146.83	90	20	35						
30	158.8	151.87	90	20	35						
31	163.9	156.92	95	20	35						
32	168.9	161.95	95	20	35						
33	174.5	167.00	95	20	35						
34	179.0	172.05	95	20	35						
35	184.1	177.10	95	20	35						
36	189.1	182.15	100	20	35						
37	194.2	187.20	100	20	35						
38	199.2	192.24	100	20	35						
39	204.2	197.29	100	20	35						
40	209.3	202.34	100	20	35						

Pitch 5/8" x 3/8"

for roller chains in compliance with
DIN 8188-ISO/R 606 - ANSI B 29.1

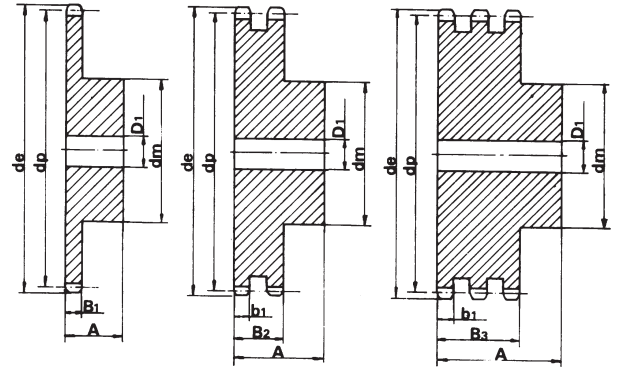
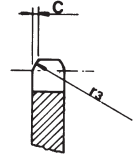

SPROCKET

TOOTH RADIUS r ₃	17
RADIUS WIDTH C	2
SPROCKET TOOTH WIDTH B ₁	9
SPROCKET TOOTH WIDTH b ₁	8.8
SPROCKET TOOTH WIDTH B ₂	26.9
SPROCKET TOOTH WIDTH B ₃	45

CHAIN

PITCH	15.875
INNER WIDTH	9.52
ROLLER - Ø	10.16

MATERIAL: C 45 UNI 7845

P L A T E W H E E L S

ASA 50

Z	d _e	d _p	S D T			Z	d _e	d _p	S D T		
			D ₁	D ₂	D ₃				D ₁	D ₂	D ₃
8	47.0	41.48	10			44	230.0	222.53	20		
9	52.6	46.42	10			45	235.0	227.58	20	20	25
10	57.5	51.37	10			46	240.1	232.63	20		
11	63.0	56.34	10			47	245.1	237.68	20		
12	68.0	61.34	10			48	250.2	242.73	20		
13	73.0	66.32	10			49	255.2	247.78	20		
14	78.0	71.34	10			50	260.3	252.82	20		
15	83.0	76.36	10			51	265.3	257.87	20		
16	88.0	81.37	12			52	270.4	262.92	20		
17	93.0	86.38	12			53	275.4	267.97	20		
18	98.3	91.42	12			54	280.5	273.03	20		
19	103.3	96.45	12			55	285.5	278.08	20		
20	108.4	101.49	12			56	290.6	283.13	25		
21	113.4	106.52	12			57	296.0	288.18	25	25	25
22	118.0	111.55	12			58	300.7	293.23	25		
23	123.4	116.58	12			59	305.7	298.27	25		
24	128.3	121.62	12			60	310.8	303.32	25		
25	134.0	126.66	12			62	321.4	313.43	25		
26	139.0	131.70	16			64	331.5	323.53	25		
27	144.0	136.75	16			65	336.5	328.58	25		
28	148.7	141.78	16			66	341.6	333.63	25		
29	153.8	146.83	16			68	351.7	343.74	25		
30	158.8	151.87	16	20	20	70	361.8	353.84	25		
31	163.9	156.92	16			72	371.9	363.95	25		
32	168.9	161.95	16			75	387.1	379.09	25		
33	174.5	167.00	16			76	392.1	384.16	25	25	30
34	179.0	172.05	16			78	402.2	394.25	25		
35	184.1	177.10	16			80	412.3	404.35	25		
36	189.1	182.15	20			85	437.6	429.62	30		
37	194.2	187.20	20			90	462.8	454.88	30		
38	199.2	192.24	20	20	25	25	95.0	480.14	30	30	
39	204.2	197.29	20			100	513.4	505.39	30		
40	209.3	202.34	20			110	563.9	555.92	30		
41	214.8	207.39	20			114	584.1	576.13	30		
42	219.9	212.44	20			120	614.4	606.45	30		
43	224.9	217.49	20			125	639.7	631.51	30		

Pitch 5/8" x 3/8"

for roller chains in compliance with
DIN 8188-ISO/R 606 - ANSI B 29.1

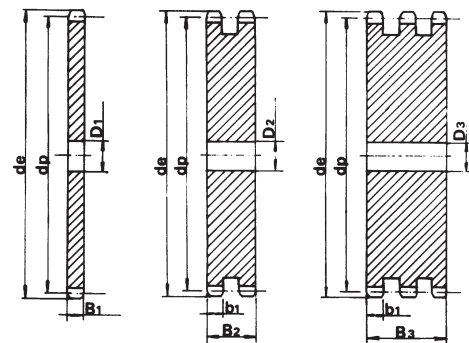
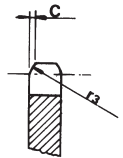

PLATEWHEEL

TOOTH RADIUS r ₃	17
RADIUS WIDTH C	2
PLATE TOOTH WIDTH B ₁	9
PLATE TOOTH WIDTH b ₁	8.8
PLATE TOOTH WIDTH B ₂	26.9
PLATE TOOTH WIDTH B ₃	45

CHAIN

PITCH	15.875
INNER WIDTH	9.52
ROLLER - Ø	10.16

S P R O C K E T S

ASA 60

Pitch 3/4" x 1/2"

for roller chains in compliance with
DIN 8188-ISO/R 606 - ANSI B 29.1

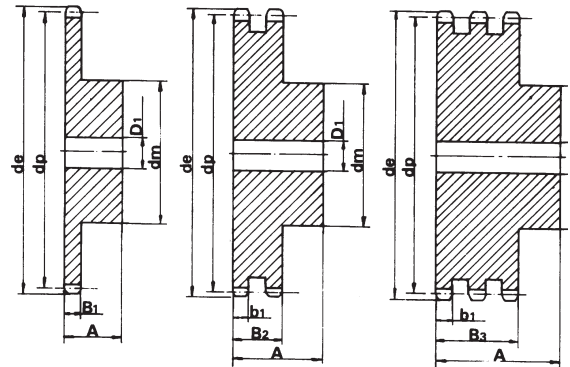
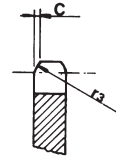

SPROCKET

mm

TOOTH RADIUS r_3	20
RADIUS WIDTH C	2.4
SPROCKET TOOTH WIDTH B_1	12.0
SPROCKET TOOTH WIDTH b_1	11.8
SPROCKET TOOTH WIDTH B_2	34.60
SPROCKET TOOTH WIDTH B_3	57.4

CHAIN

mm

PITCH	19.05
INNER WIDTH	12.7
ROLLER - \emptyset	11.91

MATERIAL: C 45 UNI 7845

Z	d_e	d_p	SINGLE			DOUBLE			TRIPLE		
			d_m	D_1	A	d_m	D_1	A	d_m	D_1	A
10	71.54	61.64	42	12	30	42	12	45			
11	77.51	67.61	45	12	30	47	16	50			
12	83.49	73.61	45	12	30	53	16	50	53	20	70
13	89.49	79.59	60	14	35	59	16	50	59	20	70
14	95.50	85.61	60	14	35	65	16	50	65	20	70
15	101.52	91.63	60	14	35	71	16	50	71	20	70
16	107.54	97.65	75	16	35	77	20	50	77	20	70
17	113.56	103.67	75	16	35	83	20	50	83	20	70
18	119.59	109.71	75	16	35	89	20	50	89	20	70
19	125.63	115.75	80	16	35	95	20	50	95	20	70
20	131.67	121.78	80	16	35	100	20	50	100	20	70
21	137.71	127.82	80	16	35	100	20	50	100	20	70
22	143.75	133.86	90	20	40	100	20	50	100	20	70
23	149.79	139.90	90	20	40	110	20	50	110	20	70
24	155.84	145.94	90	20	40	110	20	50	110	20	70
25	161.88	152.00	90	20	40	120	20	50	120	20	70
26	167.93	158.04	90	20	40	120	20	50			
27	173.98	164.09	90	20	40	120	20	50			
28	180.03	170.13	95	20	40	120	20	50			
30	192.14	182.25	95	20	40	120	20	50			

P L A T E W H E E L S

ASA 60

Pitch 3/4" x 1/2"

for roller chains in compliance with
DIN 8188-ISO/R 606 - ANSI B 29.1

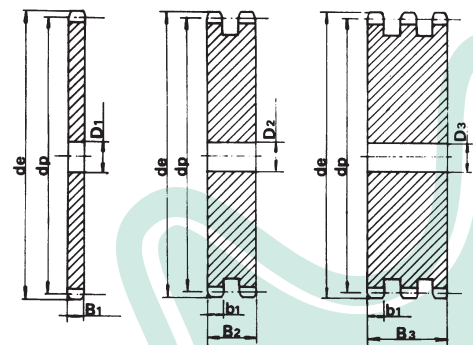
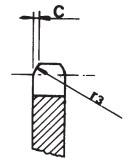

PLATEWHEEL

mm

TOOTH RADIUS r_3	20
RADIUS WIDTH C	2.4
PLATE TOOTH WIDTH B_1	12.0
PLATE TOOTH WIDTH b_1	11.8
PLATE TOOTH WIDTH B_2	34.6
PLATE TOOTH WIDTH B_3	57.4

CHAIN

mm

PITCH	19.05
INNER WIDTH	12.7
ROLLER - \emptyset	11.91

Z	d_e	d_p	S D T		
			D_1	D_2	D_3
30	192.14	182.25			20
32	204.24	194.35		20	
38	240.58	230.69	20	25	25
40	252.69	242.80	20	25	
45	282.98	273.09	25	25	25
48	301.16	291.27	25		
57	355.70	345.81	25	25	30
76	470.87	460.98	30	30	30
95	586.06	576.17		30	

S P R O C K E T S

ASA 80

Pitch 1" x 5/8"

for roller chains in compliance with
DIN 8188-ISO/R 606 - ANSI B 29.1

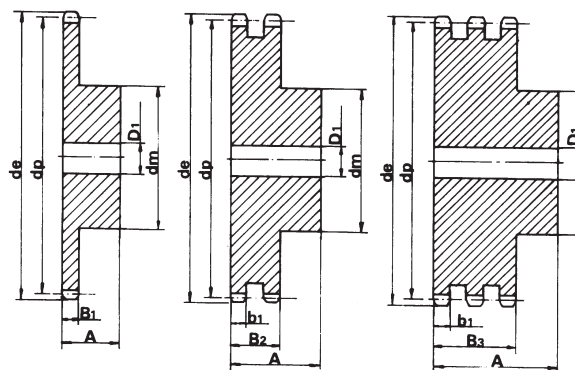
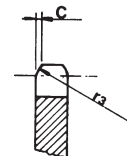

SPROCKET

TOOTH RADIUS r_3	27
RADIUS WIDTH C	3.2
SPROCKET TOOTH WIDTH B_1	15.0
SPROCKET TOOTH WIDTH b_1	14.7
SPROCKET TOOTH WIDTH B_2	44.0
SPROCKET TOOTH WIDTH B_3	73.3

CHAIN

PITCH	25.4
INNER WIDTH	15.88
ROLLER - \varnothing	15.88

MATERIAL: C 45 UNI 7845

Z	d_e	d_p	SINGLE			DOUBLE			TRIPLE		
			d_m	D_1	A	d_m	D_1	A	d_m	D_1	A
8	79.49	66.37	42	16	35						
9	87.38	74.27	50	16	35						
10	95.32	82.19	55	16	35						
11	103.28	90.14	61	16	40						
12	111.26	98.14	69	16	40	72	20	70	72	25	100
13	119.26	106.12	78	16	40	78	20	70	78	25	100
14	127.27	114.15	84	16	40	86	20	70	86	25	100
15	135.29	122.17	92	16	40	94	20	70	94	25	100
16	143.32	130.20	100	20	45	102	20	70	102	30	100
17	151.35	138.22	100	20	45	110	20	70	110	30	100
18	159.39	146.28	100	20	45	118	20	70	118	30	100
19	167.44	154.33	100	20	45	126	20	70	126	30	100
20	175.49	162.38	100	20	45	130	20	70	130	30	100
21	183.54	170.43	110	20	50	130	25	70			
22	191.60	178.48	110	20	50						
23	199.66	186.53	110	20	50						
24	207.72	194.59	110	20	50						
25	215.78	202.66	110	20	50						
26	223.84	210.72	120	20	50						
27	231.91	218.79	120	20	50						
28	239.98	226.85	120	20	50						
29	248.05	234.92	120	20	50						
30	256.12	243.00	120	20	50						

P L A T E W H E E L S

ASA 80

Pitch 1" x 5/8"

for roller chains in compliance with
DIN 8188-ISO/R 606 - ANSI B 29.1

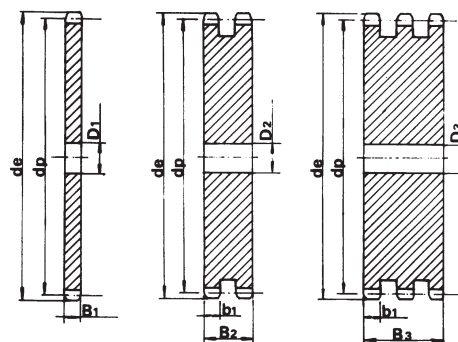
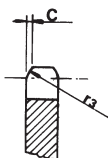

PLATEWHEEL

TOOTH RADIUS r_3	27
RADIUS WIDTH C	3.2
PLATE TOOTH WIDTH B_1	15.0
PLATE TOOTH WIDTH b_1	14.7
PLATE TOOTH WIDTH B_2	44.0
PLATE TOOTH WIDTH B_3	73.3

CHAIN

PITCH	25.4
INNER WIDTH	15.88
ROLLER - \varnothing	15.88

Z	d_e	d_p	S D T		
			D_1	D_2	D_3
10	95.32	82.19	15		
11	103.28	90.14	15		
12	111.26	98.14	15		
13	119.26	106.12	15		
14	127.27	114.15	15		
15	135.29	122.17	15		
16	143.32	130.20	19		
17	151.35	138.22	19		
18	159.39	146.28	19		
19	167.44	154.33	19		
20	175.49	162.38	19		
21	183.54	170.43	20		
22	191.60	178.48	20		
23	199.66	186.53	20		
24	207.72	194.59	20		
25	215.78	202.66	20	25	30
26	223.84	210.72	20		
27	231.91	218.79	20		
28	239.98	226.85	20		
30	256.12	243.00	20	25	30
32	272.26	259.13	25		
35	296.48	283.36	25		
38	320.70	307.59	25	25	30
45	377.24	364.12	25	25	30
50	417.64	404.52	25		
57	474.20	461.08	25	25	40
76	627.80	614.64	25	25	40

Z	d _e	d _p	SINGLE			DOUBLE		
			d _m	D ₁	A	d _m	D ₁	A
8	98.1	82.96	53	20	40			
9	108.0	92.84	63	20	40			
10	117.9	102.74	70	20	40			
11	127.8	112.68	77	20	45			
12	137.8	122.68	88	20	45			
13	147.8	132.65	98	20	45	90	20	80
14	157.8	142.68	108	20	45	100	20	80
15	167.9	152.72	118	20	45	110	20	80
16	177.9	162.75	120	25	50	120	20	80
17	187.9	172.78	120	25	50	120	25	80
18	198.0	182.85	120	25	50			
19	208.1	192.91	120	25	50			
20	218.1	202.98	120	25	50			
21	228.2	213.04	140	25	55			
22	238.3	223.11	140	25	55			
23	248.3	233.17	140	25	55			
24	258.4	243.23	140	25	55			
25	268.5	253.33	140	25	55			

Pitch 1" 1/4 x 3/4"

for roller chains in compliance with
DIN 8188-ISO/R 606 - ANSI B 29.1

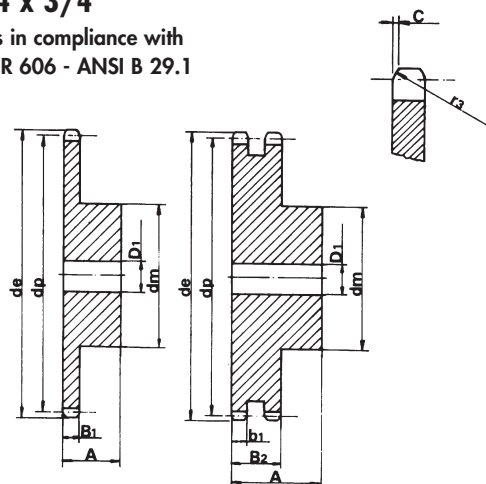

SPROCKET

	mm
TOOTH RADIUS r ₃	33.5
RADIUS WIDTH C	4
SPROCKET TOOTH WIDTH B ₁	18.0
SPROCKET TOOTH WIDTH b ₁	17.7
SPROCKET TOOTH WIDTH B ₂	53.5
SPROCKET TOOTH WIDTH B ₃	89.2

CHAIN

	mm
PITCH	31.75
INNER WIDTH	19.05
ROLLER - Ø	19.05

MATERIAL: C 45 UNI 7845

P L A T E W H E E L S

Z	d _e	d _p	S D T		
			D ₁	D ₂	D ₃
8	98.1	82.96	16		
9	108.0	92.84	16		
10	117.9	102.74	16		
11	127.8	112.68	16		
12	137.8	122.68	20		
13	147.8	132.65	20		
14	157.8	142.68	20		
15	167.9	152.72	20		
16	177.9	162.75	25		
17	187.9	172.78	25		
18	198.0	182.85	25		
19	208.1	192.91	25		
20	218.1	202.98	25	25	
21	228.2	213.04	25		
22	238.3	223.11	25		
23	248.3	233.17	25		
24	258.4	243.23	25		
25	268.5	253.33	25	25	
26	278.6	263.40	25		
27	288.6	273.40	25		
28	298.7	283.56	25		
29	308.8	293.65	25		
30	318.9	303.75	25	25	
31	329.0	313.85	25		
32	339.1	323.91	25		
33	349.2	334.01	25		
34	359.3	344.10	25		
35	369.4	354.20	25		
36	379.5	364.30	25		
37	389.5	374.39	25		
38	399.6	384.49	25	30	
39	409.7	394.59	25		
40	419.8	404.68	25		
45	470.3	455.17	30	30	
57	591.5	576.36	30	30	

Pitch 1" 1/4 x 3/4"

for roller chains in compliance with
DIN 8188-ISO/R 606 - ANSI B 29.1

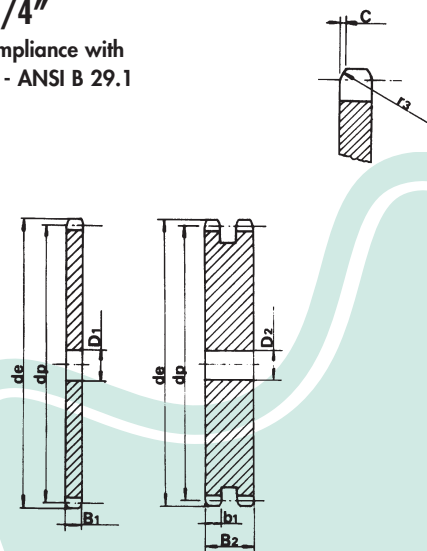

PLATEWHEEL

	mm
TOOTH RADIUS r ₃	33.5
RADIUS WIDTH C	4
PLATE TOOTH WIDTH B ₁	18.0
PLATE TOOTH WIDTH b ₁	17.7
PLATE TOOTH WIDTH B ₂	53.5
PLATE TOOTH WIDTH B ₃	89.2

CHAIN

	mm
PITCH	31.75
INNER WIDTH	19.05
ROLLER - Ø	19.05

SPROCKETS

Z	d _e	d _p	SINGLE			DOUBLE		
			d _m	D ₁	A	d _m	D ₁	A
8	119.04	99.55	58	20	45			
9	130.88	111.4	70	20	45			
10	142.77	123.29	80	20	45			
11	154.71	135.21	90	25	50			
12	166.69	147.22	102	25	50	102	25	100
13	178.68	159.18	114	25	50	114	25	100
14	190.7	171.22	128	25	50	128	25	100
15	202.73	183.26	140	25	50	140	25	100

PLATEWHEELS

Z	d _e	d _p	S	D	T
			D ₁	D ₂	
16	214.77	195.29		25	
17	226.83	207.35		25	25
18	238.89	219.41		25	25
20	263.03	243.55		25	25
22	287.2	267.72		25	
25	323.47	303.99		25	25
30	383.97	364.49		30	30
32	408.19	388.71		30	
38	480.85	461.37		30	30
45	565.67	546.19		30	40
57	711.1	691.62			40

Pitch 1" 1/2 x 1"

for roller chains in compliance with
DIN 8188-ISO/R 606 - ANSI B 29.1

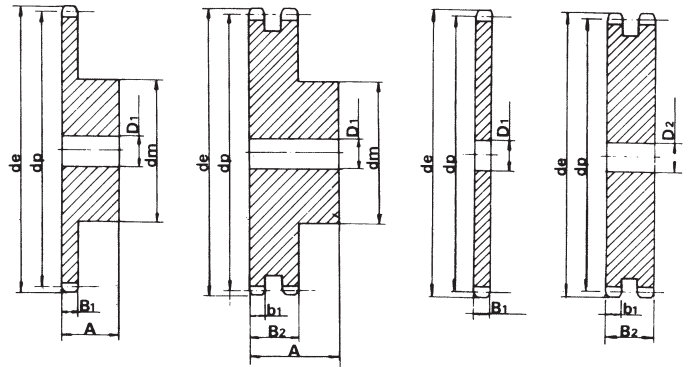
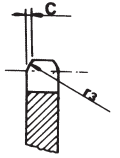

SPROCKET

	mm
TOOTH RADIUS r ₃	40.5
RADIUS WIDTH C	4.8
SPROCKET TOOTH WIDTH B ₁	24.1
SPROCKET TOOTH WIDTH b ₁	23.6
SPROCKET TOOTH WIDTH B ₂	69.0

CHAIN

	mm
PITCH	38.1
INNER WIDTH	25.4
ROLLER - Ø	22.22

MATERIAL: C 45 SPROCKETS UNI 7845

All the deleted tooth profiles are available till sold out.
At the Customer's request, we are able to produce tooth profiles and pitches in accordance with ASA profiles not shown in this Catalogue on a final cost basis.

SPROCKETS AND PLATEWHEELS DESIGNED FOR ROLLER CHAINS

The range of sprockets and wheels designed for chains manufactured by our Company provides an all-round solution to the needs of industry in the sector of flexible mechanical transmissions and is the result of a manufacturing process that is designed to achieve the top in terms of technical and quality performance.

Our production programme includes sprockets and wheels designed for chains, produced in compliance with the principles and with the most recent Standards and International Unified Standards: UNI, ISO, DIN, ANSI, etc.

However, the standards define a profile with minimum dimensions and a profile with maximum dimensions for the wheel space for chains and rollers and the actual profile must lie within these values. There is the option of selecting proportioning criteria for the profile, since the tolerances that the Standards leave to the manufacturer's discretion are quite wide. The profiles can be optimised in terms of smooth transmission and the tooth's capacity to support greater stresses. This has led to the systematic development of a series of standardised profiles for which the geometry can be reproduced with great precision by tools designed specifically by computer and the reference profile of which is protected by the Company's know-how. A valued feature of this optimised profile, which is a characteristic exclusive to **CHIARAVALLI Trasmissioni spa**, is that of enhancing the "polygonal" chain wrap-around on the sprocket and on the platewheel, reproducing the motion discontinuity which is achieved even in the case of unfavourable transmission ratios and centre distances. As a result of this **CHIARAVALLI Trasmissioni spa** has been able to include sprockets with a very low number of teeth in its catalogue and production programme.

Respecting precision with limited machining errors is beneficial, even if the toothed wheel-chain set represents a somewhat "basic" transmission solution. This precision is assured by the systematic use of CNC machines and technologies developed to minimise the shearing stress and to improve the degree of surface finish. The sprockets and wheels designed for chains included in the catalogue are also manufactured in the version with the "Taper-lock" taper bush piece system particularly favoured in applications that require easy assembly and very precise centring tolerances.

Our sales programme is completed with single and multiple roller chains, and special chains suitable for every industrial application and **CHIARAVALLI Trasmissioni spa** is also able to manufacture sprockets and platewheels suitable for chains in a specific execution, produced to drawing any of material and with induction hardening and case-hardening and hardening applied to steel wheels and sprockets.

S P R O C K E T S

5 x 2.5 mm

for roller chains in compliance with DIN 8187 ISO/R 606

Z	d _e	d _p	SINGLE		
			d _m	D1	A
8	15.2	13.06	7	4	10
9	16.8	14.62	8	5	10
10	18.3	16.18	9	5	10
11	19.9	17.75	11	6	10
12	21.5	19.32	12	6	10
13	23.0	20.89	14	6	10
14	24.6	22.47	15	6	10
15	26.2	24.04	16	6	10
16	27.8	25.63	18	8	13
17	29.4	27.20	18	8	13
18	30.9	28.79	18	8	13
19	32.5	30.38	18	8	13
20	34.1	31.96	18	8	13
21	35.7	33.54	20	8	13
22	37.3	35.13	20	8	13
23	38.9	36.72	20	8	13
24	40.5	38.30	20	8	13
25	42.0	39.89	20	8	13
26	43.6	41.48	25	8	15
27	45.2	43.07	25	8	15
28	46.8	44.65	25	8	15
29	48.4	46.25	25	8	15
30	50.0	47.83	25	8	15
31	51.6	49.42	30	8	15
32	53.2	51.01	30	8	15
33	54.8	52.60	30	8	15
34	56.3	54.19	30	8	15
35	57.9	55.78	30	8	15
36	59.5	57.37	30	8	15
37	61.1	58.96	30	8	15
38	62.7	60.54	30	8	15
39	64.3	62.13	30	8	15
40	65.9	63.73	30	8	15

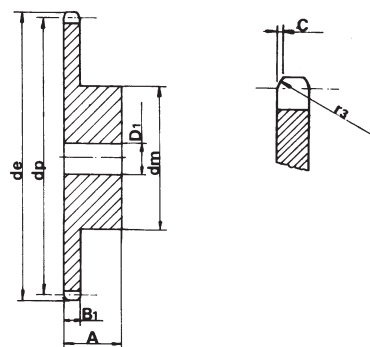

SPROCKET

mm

TOOTH RADIUS r ₃	5
RADIUS WIDTH C	0.6
SPROCKET TOOTH WIDTH B ₁	2.3

CHAIN

mm

PITCH	5
INNER WIDTH	2.5
ROLLER - Ø	3.2

MATERIAL: C 45 UNI 7845

P L A T E W H E E L S

5 x 2.5 mm

for roller chains in compliance with DIN 8187 ISO/R 606

Z	d _e	d _p	S		Z	d _e	d _p	S	
			D ₁					D ₁	
8	15.2	13.06	4		44	72.2	70.09	8	
9	16.8	14.62	4		45	73.8	71.68	8	
10	18.3	16.18	4		46	75.4	73.27	8	
11	19.9	17.75	5		47	77.0	74.86	8	
12	21.5	19.32	5		48	78.6	76.45	8	
13	23.0	20.89	5		49	80.2	78.03	8	
14	24.6	22.47	5		50	81.8	79.63	8	
15	26.2	24.04	5		51	83.4	81.22	10	
16	27.8	25.63	6		52	85.0	82.81	10	
17	29.4	27.20	6		53	86.6	84.40	10	
18	30.9	28.79	6		54	88.1	85.97	10	
19	32.5	30.38	6		55	89.7	87.58	10	
20	34.1	31.96	6		56	91.3	89.17	10	
21	35.7	33.54	8		57	92.9	90.76	10	
22	37.3	35.13	8		58	94.5	92.35	10	
23	38.9	36.72	8		59	96.1	93.94	10	
24	40.5	38.30	8		60	97.7	95.53	10	
25	42.0	39.89	8		62	100.9	98.72	12	
26	43.6	41.48	8		64	104.1	101.90	12	
27	45.2	43.07	8		65	105.6	103.49	12	
28	46.8	44.65	8		66	107.2	105.08	12	
29	48.4	46.25	8		68	110.4	108.26	12	
30	50.0	47.83	8		70	113.6	111.44	12	
31	51.6	49.42	8		72	116.8	114.63	12	
32	53.2	51.01	8		75	121.6	119.40	12	
33	54.8	52.60	8		76	123.1	120.99	12	
34	56.3	54.19	8		78	126.3	124.17	12	
35	57.9	55.78	8		80	129.5	127.35	12	
36	59.5	57.37	8		85	137.5	135.31	14	
37	61.1	58.96	8		90	145.4	143.27	14	
38	62.7	60.54	8		95	153.4	151.22	14	
39	64.3	62.13	8		100	161.3	159.18	14	
40	65.9	63.73	8		110	177.2	175.09	14	
41	67.5	65.31	8		114	183.6	181.46	14	
42	69.1	66.91	8		120	193.2	191.01	14	
43	70.6	68.49	8		125	201.1	198.96	14	

The plate size is increased by h = 4mm starting from Z.51

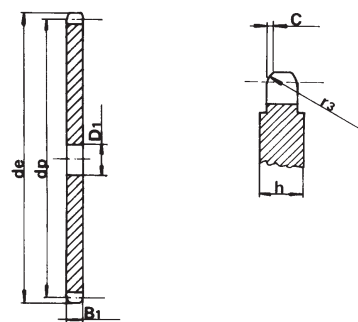

PLATEWHEEL

mm

TOOTH RADIUS r ₃	5
RADIUS WIDTH C	0.6
PLATE TOOTH WIDTH B ₁	2.3

CHAIN

mm

PITCH	5
INNER WIDTH	2.5
ROLLER - Ø	3.2

S P R O C K E T S

Z	d _e	d _p	SINGLE		
			d _m	D ₁	A
8	18.0	15.67	9.8	5	10
9	19.9	17.54	11.5	5	10
10	21.7	19.42	13	6	10
11	23.6	21.30	14	6	10
12	25.4	23.18	16	6	10
13	27.3	25.05	18	8	10
14	29.2	26.96	20	8	10
15	31.0	28.86	20	8	10
16	33.0	30.76	20	8	13
17	35.0	32.65	20	8	13
18	36.9	34.55	20	8	13
19	38.8	36.44	20	8	13
20	40.7	38.34	20	8	13
21	42.6	40.25	25	8	13
22	44.5	42.16	25	8	13
23	46.4	44.06	25	8	13
24	48.3	45.96	25	8	13
25	50.2	47.87	25	8	13
26	52.1	49.76	30	8	15
27	54.0	51.67	30	8	15
28	55.9	53.58	30	8	15
29	57.8	55.50	30	8	15
30	59.8	57.42	30	8	15
31	61.7	59.31	30	8	15
32	63.6	61.21	30	8	15
33	65.5	63.11	30	8	15
34	67.4	65.02	30	8	15
35	69.3	66.93	30	8	15
36	71.2	68.84	30	8	15
37	73.1	70.75	30	8	15
38	75.0	72.66	30	8	15
39	76.9	74.57	30	8	15
40	78.9	76.47	30	8	15
45	88.5	86.01	40	10	16
50	98.0	95.55	50	12	20
57	111.4	108.93	50	12	20
76	147.6	145.19	60	12	20

6 x 2.8 mm

for roller chains in compliance with DIN 8187 ISO/R 606

the plate is increased by h = 4mm for Z.57 and Z.76

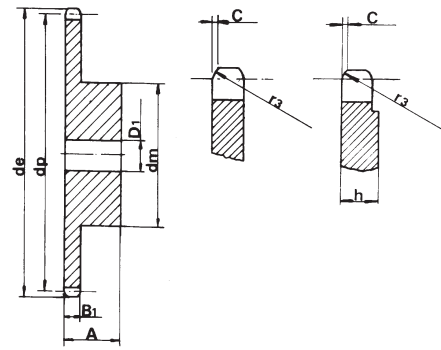

SPROCKET

	mm
TOOTH RADIUS r ₃	6
RADIUS WIDTH C	0.7
SPROCKET TOOTH WIDTH B ₁	2.6

CHAIN

	mm
PITCH	6
INNER WIDTH	2.8
ROLLER - Ø	4

MATERIAL: C 45 UNI 7845

P L A T E W H E E L S

Z	d _e	d _p	S		S		
			D ₁		D ₁		
8	18.0	15.67	5	44	86.6	84.10	10
9	19.9	17.54	5	45	88.5	86.01	10
10	21.7	19.42	6	46	90.4	87.92	10
11	23.6	21.30	6	47	92.3	89.93	10
12	25.4	23.18	6	48	94.2	91.74	10
13	27.3	25.05	8	49	96.1	93.64	10
14	29.2	26.96	8	50	98.0	95.55	10
15	31.0	28.86	8	51	99.9	97.46	12
16	33.0	30.76	8	52	101.8	99.37	12
17	35.0	32.65	8	53	103.7	101.27	12
18	36.9	34.55	8	54	105.6	103.17	12
19	38.8	36.44	8	55	107.6	105.08	12
20	40.7	38.34	8	56	109.5	107.00	12
21	42.6	40.25	8	57	111.4	108.93	12
22	44.5	42.16	8	58	113.3	110.82	12
23	46.4	44.06	8	59	115.2	112.71	12
24	48.3	45.96	8	60	117.1	114.62	12
25	50.2	47.87	8	62	120.9	118.45	14
26	52.1	49.76	8	64	124.7	122.27	14
27	54.0	51.67	8	65	126.6	124.18	14
28	55.9	53.58	8	66	128.5	126.09	14
29	57.8	55.50	8	68	132.4	129.91	14
30	59.8	57.42	8	70	136.2	133.73	14
31	61.7	59.31	8	72	140.0	137.55	16
32	63.6	61.21	8	75	145.7	143.28	16
33	65.5	63.11	8	76	147.6	145.19	16
34	67.4	65.02	8	78	151.5	149.01	16
35	69.3	66.93	8	80	155.3	152.82	16
36	71.2	68.84	8	85	164.8	162.37	16
37	73.1	70.75	8	90	174.4	171.92	16
38	75.0	72.66	8	95	183.9	181.47	16
39	76.9	74.57	8	100	193.5	191.01	16
40	78.9	76.47	8	110	212.6	210.11	16
41	80.8	78.38	10	114	220.2	217.75	16
42	82.7	80.28	10	120	231.7	229.20	16
43	84.7	82.19	10	125	241.2	238.75	16

6 x 2.8 mm

for roller chains in compliance with DIN 8187 ISO/R 606

The plate size is increased by h = 4mm starting from Z.51

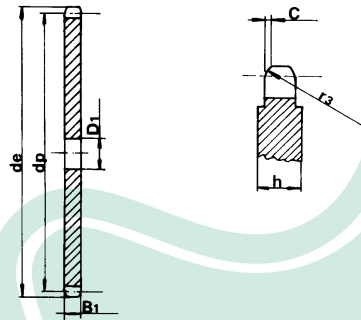

PLATEWHEEL

	mm
TOOTH RADIUS r ₃	6
RADIUS WIDTH C	0.7
PLATE TOOTH WIDTH B ₁	2.6

CHAIN

	mm
PITCH	6
INNER WIDTH	2.8
ROLLER - Ø	4

S P R O C K E T S

Z	d _e	d _p	SINGLE		
			d _m	D1	A
8	19.4	16.58	10	6	12
9	21.4	18.56	11.5	6	12
10	23.3	20.55	13	6	12
11	25.3	22.54	15	8	13
12	27.3	24.53	17	8	13
13	29.3	26.53	17	8	13
14	31.3	28.53	17	8	13
15	33.3	30.53	20	8	13
16	35.3	32.55	22	8	14
17	37.3	34.55	22	8	14
18	39.4	36.56	25	8	14
19	41.4	38.58	25	8	14
20	43.4	40.58	25	8	14
21	45.4	42.60	30	8	14
22	47.4	44.62	30	8	14
23	49.4	46.63	30	8	14
24	51.4	48.64	30	8	14
25	53.5	50.66	30	8	14
26	55.5	52.67	30	8	16
27	57.5	54.69	30	8	16
28	59.5	56.71	30	8	16
29	61.5	58.73	30	8	16
30	63.6	60.75	30	8	16
31	65.6	62.76	30	8	16
32	67.6	64.78	30	8	16
33	69.6	66.80	30	8	16
34	71.6	68.82	30	8	16
35	73.6	70.84	30	8	16
36	75.6	72.85	30	8	16
37	77.7	74.87	30	8	16
38	79.7	76.89	30	8	16
39	81.7	78.91	30	8	16
40	83.7	80.93	30	8	16

1/4" x 1/8"

for roller chains in compliance with DIN 8188 ASA 25 ISO/R 606 - ANSI B 29.1

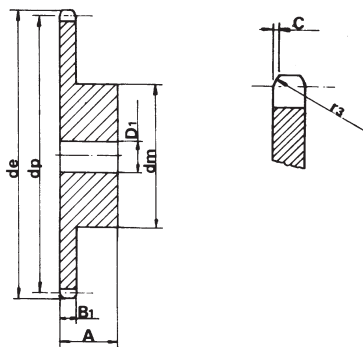

SPROCKET

TOOTH RADIUS r ₃	6.4
RADIUS WIDTH C	0.7
SPROCKET TOOTH WIDTH B ₁	2.9

CHAIN

PITCH	6.35
INNER WIDTH	3.18
ROLLER - Ø	3.3

MATERIAL: C 45 UNI 7845

P L A T E W H E E L S

Z	d _e	d _p	S			Z	d _e	d _p	D ₁
			D ₁						
8	19.4	16.58	6			44	91.8	89.01	10
9	21.4	18.56	6			45	93.8	91.03	10
10	23.3	20.55	6			46	95.8	93.05	10
11	25.3	22.54	8			47	97.9	95.07	10
12	27.3	24.53	8			48	99.9	97.09	10
13	29.3	26.53	8			49	101.9	99.10	10
14	31.3	28.53	8			50	103.9	101.13	10
15	33.3	30.53	8			51	105.9	103.14	12
16	35.3	32.55	8			52	108.0	105.16	12
17	37.3	34.55	8			53	110.0	107.18	12
18	39.4	36.56	8			54	112.0	109.18	12
19	41.4	38.58	8			55	114.0	111.23	12
20	43.4	40.58	8			56	116.0	113.25	12
21	45.4	42.60	8			57	118.1	115.27	12
22	47.4	44.62	8			58	120.1	117.29	12
23	49.4	46.63	8			59	122.1	119.31	12
24	51.4	48.64	8			60	124.1	121.32	12
25	53.5	50.66	8			62	128.2	125.37	12
26	55.5	52.67	8			64	132.2	129.41	12
27	57.5	54.69	8			65	134.2	131.43	12
28	59.5	56.71	8			66	136.2	133.45	14
29	61.5	58.73	8			68	140.3	137.49	14
30	63.6	60.75	8			70	144.3	141.53	14
31	65.6	62.76	10			72	148.4	145.58	14
32	67.6	64.78	10			75	154.4	151.63	14
33	69.6	66.80	10			76	156.5	153.66	14
34	71.6	68.82	10			78	160.5	157.70	16
35	73.6	70.84	10			80	164.5	161.74	16
36	75.6	72.85	10			85	174.6	171.85	16
37	77.7	74.87	10			90	184.7	181.95	16
38	79.7	76.89	10			95	194.8	192.05	16
39	81.7	78.91	10			100	204.9	202.15	16
40	83.7	80.93	10			110	225.1	222.37	16
41	85.7	82.95	10			114	233.2	230.45	16
42	87.8	84.97	10			120	245.4	242.58	16
43	89.8	86.98	10			125	255.5	252.68	16

1/4" x 1/8"

for roller chains in compliance with DIN 8188 ASA 25 ISO/R 606 - ANSI B 29.1

The plate size is increased by h = 4mm starting from Z.51

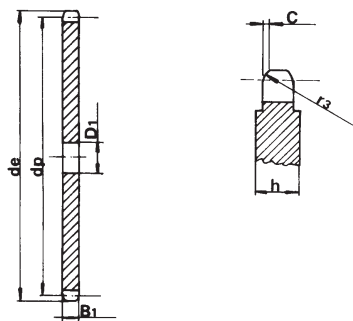

PLATEWHEEL

TOOTH RADIUS r ₃	6.4
RADIUS WIDTH C	0.7
PLATE TOOTH WIDTH B ₁	2.9

CHAIN

PITCH	6.35
INNER WIDTH	3.18
ROLLER - Ø	3.3

S P R O C K E T S

Z	d _e	d _p	SINGLE			DOUBLE		
			d _m	D ₁	A	d _m	D ₁	A
8	24.0	20.90	13	6	12	12	8	18
9	26.6	23.39	15	6	12	15	8	18
10	29.2	25.89	17	8	12	17	8	18
11	31.7	28.39	18	8	13	19	10	18
12	34.2	30.91	20	8	13	21	10	18
13	36.7	33.42	23	8	13	24	10	18
14	39.2	35.95	25	8	13	26	10	18
15	41.7	38.48	28	8	13	29	10	18
16	44.3	41.01	30	8	14	32	10	20
17	46.8	43.53	30	8	14	34	10	20
18	49.3	46.07	30	8	14	37	10	20
19	51.9	48.61	30	8	14	39	10	20
20	54.4	51.14	30	8	14	40	10	20
21	57.0	53.68	35	8	14	40	10	20
22	59.5	56.21	35	8	14	40	10	20
23	62.0	58.75	35	8	14	40	10	20
24	64.6	61.29	35	8	14	40	10	20
25	67.5	63.83	35	8	14	40	10	20
28	69.5	66.37	40	10	16	50	12	22
27	72.2	68.91	40	10	16	50	12	22
28	74.8	71.45	40	10	16	50	12	22
29	77.3	73.99	40	10	16	50	12	22
30	79.8	76.53	40	10	16	50	12	22
31	82.4	79.08	40	10	16	60	12	22
32	84.9	81.61	40	10	16	60	12	22
33	87.5	84.16	40	10	16	60	12	22
34	90.0	86.70	40	10	16	60	12	22
35	92.5	89.25	40	10	16	60	12	22
36	95.0	91.79	40	10	16	60	12	22
37	97.6	94.33	40	10	16	60	12	22
38	100.2	96.88	40	10	16	60	12	22
39	102.7	99.42	40	10	16	60	12	22
40	105.3	101.97	40	10	16	60	12	22
45	118.0	114.69	60	12	20			
50	130.7	127.41	60	12	20			
57	148.6	145.22	80	14	20			
76	197.7	193.59	80	20	25			

8 x 3 mm

for roller chains in compliance with DIN 8187 ISO/R 606

The plate size is increased by h = 4mm for Z.57 and Z.76

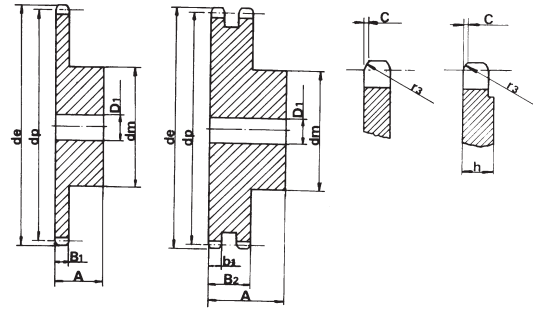

SPROCKET

TOOTH RADIUS r ₃	8
RADIUS WIDTH C	1.0
SPROCKET TOOTH WIDTH B ₁	2.8
SPROCKET TOOTH WIDTH b ₁	2.7
SPROCKET TOOTH WIDTH B ₂	8.3

CHAIN

PITCH	8
INNER WIDTH	3
ROLLER - Ø	5

MATERIAL: C 45 UNI 7845

P L A T E W H E E L S

Z	d _e	d _p	S		D		Z	d _e	d _p	S		D	
			D ₁	D ₂	D ₁	D ₂				D ₁	D ₂		
8	24.0	20.90	6	6	44	115.5	112.14	12	14				
9	26.6	23.39	6	6	45	118.0	114.69	12	14				
10	29.2	25.89	6	8	46	120.6	117.23	12	14				
11	31.7	28.39	8	8	47	123.1	119.77	12	14				
12	34.2	30.91	8	8	48	125.6	122.32	12	14				
13	36.7	33.42	8	8	49	128.2	124.86	12	14				
14	39.2	35.95	8	8	50	130.7	127.41	12	14				
15	41.7	38.48	8	8	51	133.3	129.95	14	16				
16	44.3	41.01	8	10	52	135.8	132.49	14	16				
17	46.8	43.53	8	10	53	138.4	135.04	14	16				
18	49.3	46.07	8	10	54	140.9	137.59	14	16				
19	51.9	48.61	8	10	55	143.5	140.13	14	16				
20	54.4	51.14	8	10	56	146.0	142.68	14	16				
21	57.0	53.68	8	10	57	148.6	145.22	14	16				
22	59.5	56.21	8	10	58	151.0	147.77	14	16				
23	62.0	58.75	8	10	59	153.6	150.31	14	16				
24	64.6	61.29	8	10	60	156.2	152.85	14	16				
25	67.5	63.83	8	10	62	162.0	157.95	16	20				
26	69.5	66.37	10	12	64	167.1	163.04	16	20				
27	72.2	68.91	10	12	65	169.6	165.58	16	20				
28	74.8	71.45	10	12	66	172.2	168.13	16	20				
29	77.3	73.99	10	12	68	177.3	173.22	16	20				
30	79.8	76.53	10	12	70	182.4	178.31	16	20				
31	82.4	79.08	10	12	72	187.5	183.41	20	20				
32	84.9	81.61	10	12	75	195.1	191.04	20	20				
33	87.5	84.16	10	12	76	197.7	193.59	20	20				
34	90.0	86.70	10	12	78	202.8	198.68	20	20				
35	92.5	89.25	10	12	80	207.9	203.77	20	20				
36	95.0	91.79	10	12	85	220.6	216.50	20	20				
37	97.6	94.33	10	12	90	233.4	229.23	20	20				
38	100.2	96.88	10	12	95	246.1	241.96	20	20				
39	102.7	99.42	10	12	100	258.9	254.68	20	20				
40	105.3	101.97	10	12	110	284.3	280.15	20	20				
41	107.8	104.51	12	14	114	294.5	290.33	20	20				
42	110.4	107.05	12	14	120	310.0	305.61	20	20				
43	112.9	109.60	12	14	125	322.5	318.34	20	20				

8 x 3 mm

for roller chains in compliance with DIN 8187 ISO/R 606

The plate size is increased by h = 4mm starting from Z.46

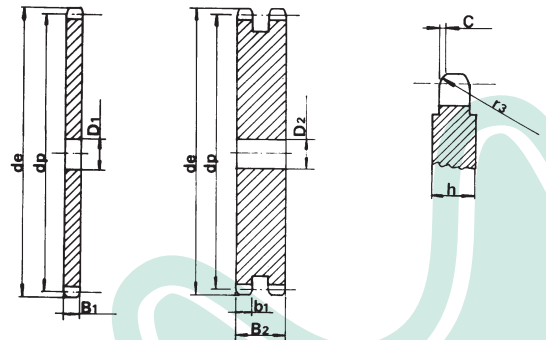

PLATEWHEEL

TOOTH RADIUS r ₃	8
RADIUS WIDTH C	1.0
PLATE TOOTH WIDTH B ₁	2.8
PLATE TOOTH WIDTH b ₁	2.7
PLATE TOOTH WIDTH B ₂	8.3

CHAIN

PITCH	8
INNER WIDTH	3
ROLLER - Ø	5

S P R O C K E T S

1/2" x 1/8"

for roller chains in compliance with DIN 8187 ISO/R 606

The plate size is increased by $h = 5$ mm starting from Z.31

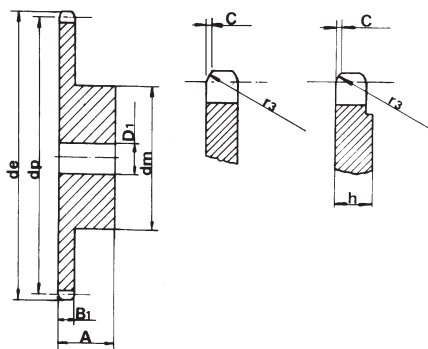

SPROCKET mm

TOOTH RADIUS r_3	13
RADIUS WIDTH C	1.0
SPROCKET TOOTH WIDTH B_1	3

CHAIN mm

PITCH	12.7
INNER WIDTH	3.3
ROLLER - \varnothing	7.75

MATERIAL: C 45 UNI 7845

Z	d_e	d_p	SINGLE		
			d_m	D_1	A
8	37.2	33.18	21	8	14
9	41.5	37.13	25	8	14
10	46.2	41.10	28	8	14
11	49.6	45.07	31	8	16
12	53.9	49.07	35	8	16
13	58.4	53.06	39	8	16
14	62.8	57.07	43	8	16
15	66.8	61.09	47	8	16
16	70.9	65.10	50	10	18
17	74.9	69.11	50	10	18
18	78.9	73.14	50	10	18
19	82.9	77.16	50	10	18
20	86.9	81.19	50	10	18
21	91.0	85.22	60	12	20
22	95.0	89.24	60	12	20
23	99.0	93.27	60	12	20
24	103.0	97.29	60	12	20
25	107.1	101.33	60	12	20
26	111.2	105.36	70	16	20
27	115.4	109.40	70	16	20
28	119.4	113.42	70	16	20
29	123.4	117.46	70	16	20
30	127.5	121.50	70	16	20
31	131.5	125.54	70	16	20
32	135.5	129.56	70	16	20
33	139.6	133.60	70	16	20
34	143.6	137.64	70	16	20
35	147.6	141.68	70	16	20
36	151.7	145.72	70	16	25
37	155.7	149.76	70	16	25
38	159.8	153.80	70	16	25
39	163.8	157.83	70	16	25
40	167.8	161.87	70	16	25

P L A T E W H E E L S

1/2" x 1/8"

for roller chains in compliance with DIN 8187 ISO/R 606

The plate size is increased by $h = 4$ mm starting from Z.30

The plate size is increased by $h = 6$ mm starting from Z.90

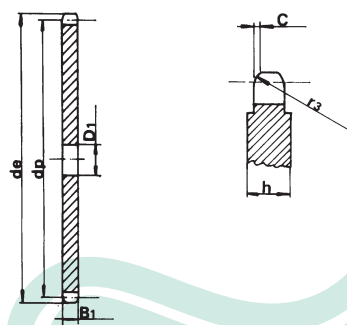

PLATEWHEEL mm

TOOTH RADIUS r_3	13
RADIUS WIDTH C	1.0
PLATE TOOTH WIDTH B_1	3

CHAIN mm

PITCH	12.7
INNER WIDTH	3.3
ROLLER - \varnothing	7.75

Z	d_e	d_p	S	
			D_1	D_1
8	37.2	33.18	8	43
9	41.5	37.13	8	44
10	46.2	41.10	8	45
11	49.6	45.07	8	46
12	53.9	49.07	8	47
13	58.4	53.06	8	48
14	62.8	57.07	8	49
15	66.8	61.09	8	50
16	70.9	65.10	10	51
17	74.9	69.11	10	52
18	78.9	73.14	10	53
19	82.9	77.16	10	54
20	86.9	81.19	10	55
21	91.0	85.22	10	56
22	95.0	89.24	10	57
23	99.0	93.27	10	58
24	103.0	97.29	10	59
25	107.1	101.33	10	60
26	111.2	105.36	12	62
27	115.4	109.40	12	64
28	119.4	113.42	12	65
29	123.4	117.46	12	66
30	127.5	121.50	12	68
31	131.5	125.54	12	70
32	135.5	129.56	12	72
33	139.6	133.60	12	76
34	143.6	137.64	12	78
35	147.6	141.68	12	80
36	151.7	145.72	16	85
37	155.7	149.76	16	90
38	159.8	153.80	16	95
39	163.8	157.83	16	100
40	167.8	161.87	16	110
41	171.4	165.91	16	114
42	175.4	169.95	16	120
				125

S P R O C K E T S

1/2" x 3/16"

for roller chains in compliance with DIN 8187 ISO/R 606

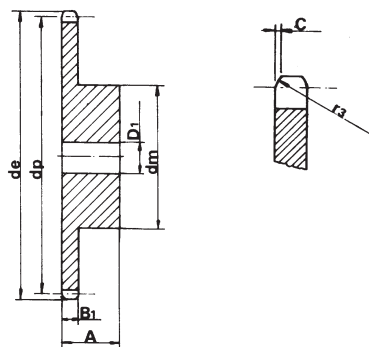

SPROCKET

mm

TOOTH RADIUS r_3	13
RADIUS WIDTH C	1.3
SPROCKET TOOTH WIDTH B_1	4.5

CHAIN

mm

PITCH	12.7
INNER WIDTH	4.88
ROLLER - \varnothing	7.75

MATERIAL: C 45 UNI 7845

Z	d_e	d_p	SINGLE		
			d_m	D_1	A
8	38.5	33.18	21	8	14
9	41.5	37.13	25	8	14
10	46.2	41.10	28	8	14
11	49.6	45.07	31	8	16
12	53.9	49.07	35	8	16
13	58.4	53.06	39	8	16
14	62.8	57.07	43	8	16
15	66.8	61.09	47	8	16
16	70.9	65.10	50	10	18
17	74.9	69.11	50	10	18
18	78.9	73.14	50	10	18
19	82.9	77.16	50	10	18
20	88.9	81.19	50	10	18
21	91.0	85.22	60	12	20
22	95.0	89.24	60	12	20
23	99.0	93.27	60	12	20
24	103.0	97.29	60	12	20
25	107.1	101.33	60	12	20
26	111.2	105.36	70	16	20
27	115.4	109.40	70	16	20
28	119.4	113.42	70	16	20
29	123.4	117.46	70	16	20
30	127.5	121.50	70	16	20
31	131.5	125.54	70	16	20
32	135.5	129.56	70	16	20
33	139.6	133.60	70	16	20
34	143.6	137.64	70	16	20
35	147.6	141.68	70	16	20
36	151.7	145.72	70	16	25
37	155.7	149.76	70	16	25
38	159.8	153.80	70	16	25
39	163.8	157.83	70	16	25
40	167.8	161.87	70	16	25

P L A T E W H E E L S

1/2" x 3/16"

for roller chains in compliance with DIN 8187 ISO/R 606

The plate size is increased by $h = 6$ mm starting from Z.90

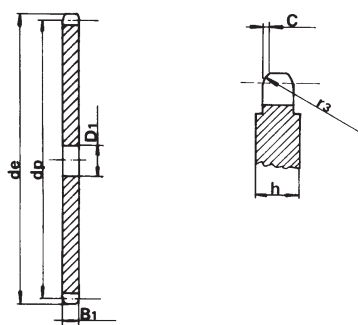

PLATEWHEEL

mm

TOOTH RADIUS r_3	13
RADIUS WIDTH C	1.3
PLATE TOOTH WIDTH B_1	4.3 ± 0.2

CHAIN

mm

PITCH	12.7
INNER WIDTH	4.88
ROLLER - \varnothing	7.75

Z	d_e	d_p	S		S		
			D_1		D_1		
8	38.5	33.18	8	43	179.5	173.99	16
9	41.5	37.13	8	44	183.5	178.03	16
10	46.2	41.10	8	45	187.5	182.07	16
11	49.6	45.07	8	46	191.6	186.10	20
12	53.9	49.07	8	47	195.6	190.14	20
13	58.4	53.06	8	48	199.7	194.18	20
14	62.8	57.07	8	49	203.7	198.22	20
15	66.8	61.09	8	50	207.8	202.26	20
16	70.9	65.10	10	51	211.8	206.30	20
17	74.9	69.11	10	52	215.9	210.34	20
18	78.9	73.14	10	53	219.9	214.37	20
19	82.9	77.16	10	54	224.0	218.43	20
20	86.9	81.19	10	55	228.0	222.46	20
21	91.0	85.22	10	56	232.1	226.50	20
22	95.0	89.24	10	57	236.1	230.54	20
23	99.0	93.27	10	58	240.2	234.58	20
24	103.0	97.29	10	59	244.2	238.62	20
25	107.1	101.33	10	60	248.2	242.66	20
26	111.2	105.36	12	62	256.7	250.75	20
27	115.4	109.40	12	64	264.8	258.82	20
28	119.4	113.42	12	65	268.8	262.86	20
29	123.4	117.46	12	66	272.9	266.90	25
30	127.5	121.50	12	68	280.9	274.99	25
31	131.5	125.54	12	70	289.0	283.07	25
32	135.5	129.56	12	72	297.1	291.16	25
33	139.6	133.60	12	76	313.3	307.33	25
34	143.6	137.64	12	78	321.4	315.40	25
35	147.6	141.68	12	80	329.4	323.48	25
36	151.7	145.72	16	85	349.7	343.70	25
37	155.7	149.76	16	90	369.9	363.90	25
38	159.8	153.80	16	95	390.1	384.10	25
39	163.8	157.83	16	100	410.3	404.31	25
40	167.8	161.87	16	110	450.7	444.74	25
41	171.4	165.91	16	114	466.9	460.90	25
42	175.4	169.95	16	120	491.2	485.16	25
				125	511.4	505.37	25

S P R O C K E T S

1/2" x 1/4" - 7.75 roller size

for roller chains in compliance with DIN 8187 ISO/R 606

Z	d _e	d _p	SINGLE		
			d _m	D ₁	A
8	38.5	33.18	20	10	25
9	41.5	37.13	24	10	25
10	46.2	41.10	26	10	25
11	49.6	45.07	29	10	25
12	53.9	49.07	33	10	28
13	58.4	53.06	37	10	28
14	62.8	57.07	41	10	28
15	66.8	61.09	45	10	28
16	70.9	65.10	50	12	28
17	74.9	69.11	52	12	28
18	78.9	73.14	56	12	28
19	82.9	77.16	60	12	28
20	86.9	81.19	64	12	28
21	91.0	85.22	68	14	28
22	95.0	89.24	70	14	28
23	99.0	93.27	70	14	28
24	103.0	97.29	70	14	28
25	107.1	101.33	70	14	28
26	111.2	105.36	70	16	30
27	115.4	109.40	70	16	30
28	119.4	113.42	70	16	30
29	123.4	117.46	80	16	30
30	127.5	121.50	80	16	30
31	131.5	125.54	90	16	30
32	135.5	129.56	90	16	30
33	139.6	133.60	90	16	30
34	143.6	137.64	90	16	30
35	147.6	141.68	90	16	30
36	151.7	145.72	90	16	35
37	155.7	149.76	90	16	35
38	159.8	153.80	90	16	35
39	163.8	157.83	90	16	35
40	167.8	161.87	90	16	35

Sprocket sizes subject to availability

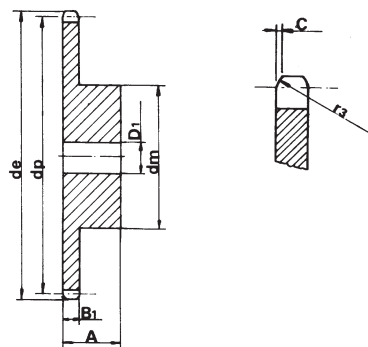

SPROCKET

TOOTH RADIUS r ₃	13
RADIUS WIDTH C	1.3
SPROCKET TOOTH WIDTH B ₁	5.9

CHAIN

PITCH	12.7
INNER WIDTH	6.4
ROLLER - Ø	7.75

MATERIAL: C 45 UNI 7845

P L A T E W H E E L S

1/2" x 1/4" - 7.75 roller size

for roller chains in compliance with DIN 8187 ISO/R 606

Z	d _e	d _p	S				
			D ₁	Z	d _e	d _p	D ₁
8	38.5	33.18	8	43	179.5	173.99	16
9	41.5	37.13	8	44	183.5	178.03	16
10	46.2	41.10	8	45	187.5	182.07	16
11	49.6	45.07	8	46	191.6	186.10	20
12	53.9	49.07	8	47	195.6	190.14	20
13	58.4	53.06	8	48	199.7	194.18	20
14	62.8	57.07	8	49	203.7	198.22	20
15	66.8	61.09	8	50	207.8	202.26	20
16	70.9	65.10	10	51	211.8	206.30	20
17	74.9	69.11	10	52	215.9	210.34	20
18	78.9	73.14	10	53	219.9	214.37	20
19	82.9	77.16	10	54	224.0	218.43	20
20	86.9	81.19	10	55	228.0	222.46	20
21	91.0	85.22	10	56	232.1	226.50	20
22	95.0	89.24	10	57	236.1	230.54	20
23	99.0	93.27	10	58	240.2	234.58	20
24	103.0	97.29	10	59	244.2	238.62	20
25	107.1	101.33	10	60	248.2	242.66	20
26	111.2	105.36	12	62	256.7	250.75	20
27	115.4	109.40	12	64	264.8	258.82	20
28	119.4	113.42	12	65	268.8	262.86	20
29	123.4	117.46	12	66	272.9	266.90	25
30	127.5	121.50	12	68	280.9	274.99	25
31	131.5	125.54	12	70	289.0	283.07	25
32	135.5	129.56	12	72	297.1	291.16	25
33	139.6	133.60	12	76	313.3	307.33	25
34	143.6	137.64	12	78	321.4	315.40	25
35	147.6	141.68	12	80	329.4	323.48	25
36	151.7	145.72	16	85	349.7	343.70	25
37	155.7	149.76	16	90	369.9	363.90	25
38	159.8	153.80	16	95	390.1	384.10	25
39	163.8	157.83	16	100	410.3	404.31	25
40	167.8	161.87	16	110	450.7	444.74	25
41	171.4	165.91	16	114	466.9	460.90	25
42	175.4	169.95	16	120	491.2	485.16	25
				125	511.4	505.37	25

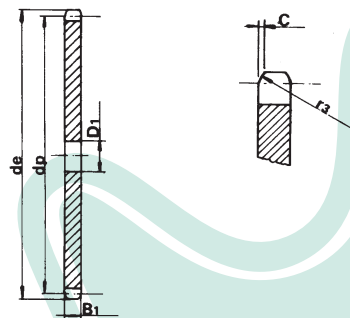

PLATEWHEEL

TOOTH RADIUS r ₃	13
RADIUS WIDTH C	1.3
PLATE TOOTH WIDTH B ₁	5.9

CHAIN

PITCH	12.7
INNER WIDTH	6.4
ROLLER - Ø	7.75

S P R O C K E T S

1/2" x 1/4" - 8.51 roller size

for roller chains in compliance with DIN 8187 ISO/R 606

Z	d _e	d _p	SINGLE		
			d _m	D ₁	A
8	37.2	33.18	20	10	25
9	41.0	37.13	24	10	25
10	45.2	41.10	26	10	25
11	48.7	45.07	29	10	25
12	53.0	49.07	33	10	28
13	57.4	53.06	37	10	28
14	61.8	57.07	41	10	28
15	65.5	61.09	45	10	28
16	69.5	65.10	50	12	28
17	73.6	69.11	52	12	28
18	77.8	73.14	56	12	28
19	81.7	77.16	60	12	28
20	85.8	81.19	64	12	28
21	89.7	85.22	68	14	28
22	93.8	89.24	70	14	28
23	98.2	93.27	70	14	28
24	101.8	97.29	70	14	28
25	105.8	101.33	70	14	28
26	110.0	105.36	70	16	30
27	114.0	109.40	70	16	30
28	118.0	113.42	70	16	30
29	122.0	117.46	80	16	30
30	126.1	121.50	80	16	30
31	130.2	125.54	90	16	30
32	134.3	129.56	90	16	30
33	138.4	133.60	90	16	30
34	142.6	137.64	90	16	30
35	146.7	141.68	90	16	30
36	151.0	145.72	90	16	35
37	154.6	149.76	90	16	35
38	158.6	153.80	90	16	35
39	162.7	157.83	90	16	35
40	166.8	161.87	90	16	35

Pignoni ad esaurimento

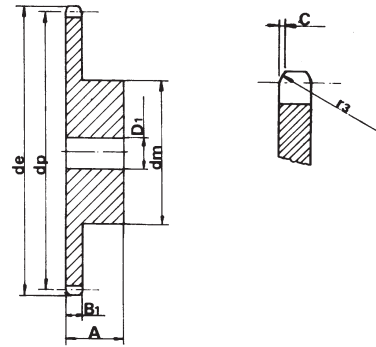

SPROCKET

	mm
TOOTH RADIUS r ₃	13
RADIUS WIDTH C	1.3
SPROCKET TOOTH WIDTH B ₁	5.9

CHAIN

	mm
PITCH	12.7
INNER WIDTH	6.4
ROLLER - Ø	8.51

MATERIAL: C 45 UNI 7845

P L A T E W H E E L S

1/2" x 1/4" - 8.51 roller size

for roller chains in compliance with DIN 8187 ISO/R 606

Z	d _e	d _p	S				
			D ₁	Z	d _e	d _p	D ₁
8	37.2	33.18	8	43	179.7	173.99	16
9	41.0	37.13	8	44	183.8	178.03	16
10	45.2	41.10	8	45	188.0	182.07	16
11	48.7	45.07	8	46	192.1	186.10	20
12	53.0	49.07	8	47	196.2	190.14	20
13	57.4	53.06	8	48	200.3	194.18	20
14	61.8	57.07	8	49	204.3	198.22	20
15	65.5	61.09	8	50	208.3	202.26	20
16	69.5	65.10	10	51	212.1	206.30	20
17	73.6	69.11	10	52	216.1	210.34	20
18	77.8	73.14	10	53	220.2	214.37	20
19	81.7	77.16	10	54	224.1	218.43	20
20	85.8	81.19	10	55	228.1	222.46	20
21	89.7	85.22	10	56	232.2	226.50	20
22	93.8	89.24	10	57	236.4	230.54	20
23	98.2	93.27	10	58	240.5	234.58	20
24	101.8	97.29	10	59	244.5	238.62	20
25	105.8	101.33	10	60	248.6	242.66	20
26	110.0	105.36	12	62	256.9	250.75	20
27	114.0	109.40	12	64	265.1	258.82	20
28	118.0	113.42	12	65	269.0	262.86	20
29	122.0	117.46	12	66	273.0	266.90	25
30	126.1	121.50	12	68	281.0	274.99	25
31	130.2	125.54	12	70	289.0	283.07	25
32	134.2	129.56	12	72	297.2	291.16	25
33	138.4	133.60	12	76	313.3	307.33	25
34	142.6	137.64	12	78	321.4	315.40	25
35	146.7	141.68	12	80	329.4	323.48	25
36	151.0	145.72	16	85	349.0	343.70	25
37	154.6	149.76	16	90	369.9	363.90	25
38	158.6	153.80	16	95	390.1	384.10	25
39	162.7	157.83	16	100	410.3	404.31	25
40	166.8	161.87	16	110	450.7	444.74	25
41	171.4	165.91	16	114	466.9	460.90	25
42	175.4	169.95	16	120	491.2	485.16	25
				125	511.3	505.37	25

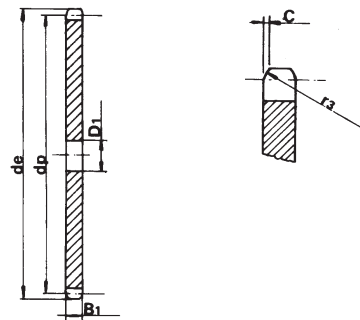

PLATEWHEEL

	mm
TOOTH RADIUS r ₃	13
RADIUS WIDTH C	1.3
PLATE TOOTH WIDTH B ₁	5.9

CHAIN

	mm
PITCH	12.7
INNER WIDTH	6.4
ROLLER - Ø	8.51

S P R O C K E T S

Z	d _e	d _p	SINGLE			DOUBLE			TRIPLE		
			d _m	D ₁	A	d _m	D ₁	A	d _m	D ₁	A
			8	77.0	66.37	42	16	35	42	16	65
9	85.0	74.27	50	16	35	50	16	65	50	20	95
10	93.0	82.19	55	16	35	56	16	65	56	20	95
11	99.5	90.14	61	16	40	64	20	70	64	25	100
12	109.0	98.14	69	16	40	72	20	70	72	25	100
13	117.0	106.12	78	16	40	80	20	70	80	25	100
14	125.0	114.15	84	16	40	88	20	70	88	25	100
15	133.0	122.17	92	16	40	96	20	70	96	25	100
16	141.0	130.20	100	20	45	104	20	70	104	30	100
17	149.0	138.22	100	20	45	112	20	70	112	30	100
18	157.0	146.28	100	20	45	120	20	70	120	30	100
19	165.2	154.33	100	20	45	128	20	70	128	30	100
20	173.2	162.38	100	20	45	130	20	70	130	30	100
21	181.2	170.43	110	20	50	130	25	70	*130	30	100
22	189.3	178.48	110	20	50	*130	25	70	*130	30	100
23	197.5	186.53	110	20	50	*130	25	70	*130	30	100
24	205.5	194.59	110	20	50	*130	25	70	*130	30	100
25	213.5	202.66	110	20	50	*130	25	70	*130	30	100
26	221.6	210.72	120	20	50	*130	25	70	*130	30	100
27	229.6	218.79	120	20	50	*130	25	70	*130	30	100
28	237.7	226.85	120	20	50	*130	25	70	*130	30	100
29	245.8	234.92	120	20	50	*130	25	70	*130	30	100
30	254.0	243.00	120	20	50	*130	25	70	*130	30	100
31	262.0	251.08	*120	25	50	*140	25	70	*140	30	100
32	270.0	259.13	*120	25	50	*140	25	70	*140	30	100
33	278.5	267.21	*120	25	50	*140	25	70	*140	30	100
34	287.0	275.28	*120	25	50	*140	25	70	*140	30	100
35	296.2	283.36	*120	25	50	*140	25	70	*140	30	100
36	304.6	291.44	*120	25	50	*140	25	70	*140	30	100
37	312.6	299.51	*120	25	50	*140	25	70	*140	30	100
38	320.7	307.59	*120	25	50	*140	25	70	*140	30	100
39	328.8	315.67	*120	25	50	*140	25	70	*140	30	100
40	336.9	323.75	*120	25	50	*140	25	70	*140	30	100

1" x 17.02 mm
for roller chains in compliance with
DIN 8187 ISO/R 606

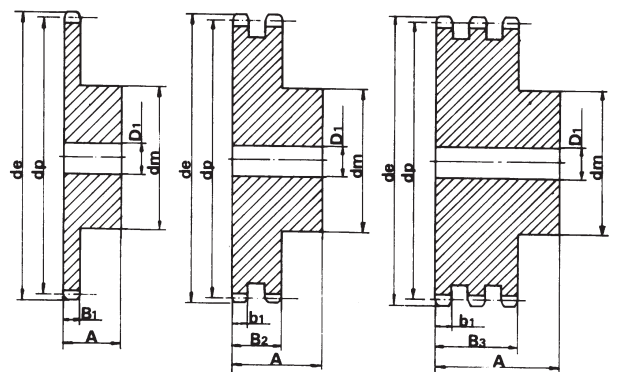
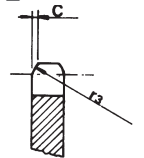

SPROCKET mm

TOOTH RADIUS r ₃	26
RADIUS WIDTH C	2.5
SPROCKET TOOTH WIDTH B ₁	16.2
SPROCKET TOOTH WIDTH b ₁	15.8
SPROCKET TOOTH WIDTH B ₂	47.7
SPROCKET TOOTH WIDTH B ₃	79.6

CHAIN mm

PITCH	25.4
INNER WIDTH	17.02
ROLLER - Ø	15.88

MATERIAL: C 45 UNI 7845 *MATERIAL: FE - WITH WELDED HUB

P L A T E W H E E L S

Z	d _e	d _p	S D T			Z	d _e	d _p	S D T		
			D ₁	D ₂	D ₃				D ₁	D ₂	D ₃
8	77.0	66.37	14	16	20	44	369.1	356.06	25	25	30
9	85.0	74.27	14	16	20	45	377.1	364.13	25	25	30
10	93.0	82.19	15	16	20	46	385.2	372.21	25	30	30
11	99.5	90.14	15	20	25	47	393.2	380.29	25		
12	109.0	98.14	15	20	25	48	401.3	388.36	25	30	30
13	117.0	106.12	15	20	25	49	409.3	396.44	25		
14	125.0	114.15	15	20	25	50	417.4	404.52	25	30	30
15	133.0	122.17	15	20	25	51	425.5	412.60	30	30	40
16	141.0	130.20	19	20	30	52	433.6	420.67	30	30	40
17	149.0	138.22	19	20	30	53	441.7	428.75	30		
18	157.0	146.28	19	20	30	54	448.3	436.85	30		
19	165.2	154.33	19	20	30	55	457.9	444.93	30	30	40
20	173.0	162.38	19	20	30	56	466.0	453.01	30	30	
21	181.2	170.43	20	25	30	57	474.0	461.07	30	30	40
22	189.3	178.48	20	25	30	58	482.1	469.16	30		
23	197.5	186.53	20	25	30	59	490.2	477.24	30		
24	205.5	194.59	20	25	30	60	498.3	485.32	30	30	40
25	213.5	202.66	20	25	30	62	514.5	501.50	30	30	
26	221.6	210.72	20	25	30	64	530.7	517.65	30		
27	229.6	218.79	20	25	30	65	538.8	525.73	30	30	40
28	237.7	226.85	20	25	30	66	546.8	533.80	30		
29	245.8	234.92	20	25	30	68	562.9	549.98	30	30	40
30	254.0	243.00	20	25	30	70	579.2	566.14	30	30	40
31	262.0	251.08	25	25	30	72	595.4	582.32	30	30	40
32	270.0	259.13	25	25	30	75	619.7	606.55	30	30	40
33	278.5	267.21	25	25	30	76	627.0	614.65	30	30	40
34	287.0	275.28	25	25	30	78	643.3	630.80	30		
35	296.2	283.36	25	25	30	80	660.0	646.96	30	30	40
36	304.6	291.44	25	25	30	85	699.9	687.40	30	30	40
37	312.6	299.51	25	25	30	90	740.3	727.81	30	30	40
38	320.7	307.59	25	25	30	95	781.1	768.22	30	30	40
39	328.8	315.67	25	25	30	100	821.1	808.63	30	30	40
40	336.9	323.75	25	25	30	110	902.0	889.48	30	30	40
41	345.0	331.82	25			114	934.3	921.81	30	40	40
42	353.0	339.90	25	25	30	120	982.8	970.33	30	40	40
43	361.1	347.98	25	25		125	1023.2	1010.73	30	40	40

1" x 17.02 mm
for roller chains in compliance with
DIN 8187 ISO/R 606

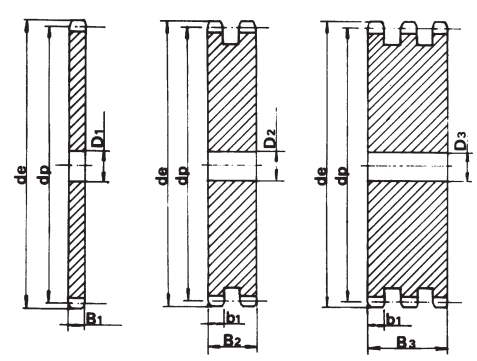
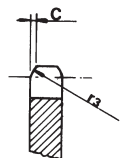

SPROCKET mm

TOOTH RADIUS r ₃	26
RADIUS WIDTH C	2.5
PLATE TOOTH WIDTH B ₁	16.2
PLATE TOOTH WIDTH b ₁	15.8
PLATE TOOTH WIDTH B ₂	47.7
PLATE TOOTH WIDTH B ₃	79.6

CHAIN mm

PITCH	25.4
INNER WIDTH	17.02
ROLLER - Ø	15.88

S P R O C K E T S

1" 1/2 x 1"

for roller chains in compliance with
DIN 8187 ISO/R 606

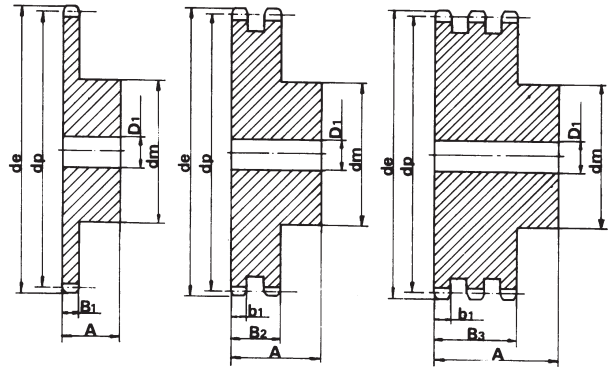
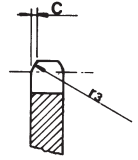

SPROCKET mm

TOOTH RADIUS r_3	38
RADIUS WIDTH C	4
SPROCKET WIDTH B_1	24.1
SPROCKET TOOTH WIDTH b_1	23.6
SPROCKET TOOTH WIDTH B_2	72
SPROCKET TOOTH WIDTH B_3	120.3

CHAIN mm

PITCH	38.1
INNER WIDTH	25.4
ROLLER - \emptyset	25.4

MATERIAL: C 45 UNI 7845 *MATERIAL: FE - WITH WELDED HUB

Z	d_e	d_p	SINGLE			DOUBLE			TRIPLE		
			d_m	D_1	A	d_m	D_1	A	d_m	D_1	A
8	115.0	99.55	58	20	45	58	25	95	58	25	140
9	126.4	111.40	70	20	45	70	25	95	70	25	140
10	138.0	123.29	80	20	45	80	25	95	80	25	140
11	150.0	135.21	90	25	50	90	25	100	90	25	150
12	162.0	147.22	102	25	50	102	25	100	102	25	150
13	174.2	159.18	114	25	50	114	25	100	114	25	150
14	186.2	171.22	128	25	50	128	25	100	128	25	150
15	198.2	183.26	140	25	50	140	25	100	140	25	150
16	210.3	195.30	*140	25	55	*140	25	100	*140	25	150
17	222.3	207.34	*140	25	55	*150	25	100	*150	25	150
18	234.3	219.42	*140	25	55	*160	25	100	*160	25	150
19	246.5	231.49	*140	25	55	*160	25	100	*160	25	150
20	258.6	243.57	*140	25	55	*160	25	100	*160	25	150
21	270.6	255.65	*150	25	60	*160	25	100	*160	30	150
22	282.7	267.73	*150	25	60	*160	25	100	*160	30	150
23	294.8	279.80	*150	25	60	*160	25	100	*160	30	150
24	306.8	291.88	*150	25	60	*160	25	100	*160	30	150
25	319.0	304.00	*150	25	60	*160	25	100	*160	30	150
26	331.0	316.08	*160	30	60	*160	30	100	*160	30	150
27	343.2	328.19	*160	30	60	*160	30	100	*160	30	150
28	355.2	340.27	*160	30	60	*160	30	100	*160	30	150
29	367.3	352.38	*160	30	60	*160	30	100	*160	30	150
30	379.5	364.50	*160	30	60	*160	30	100	*160	40	150
31	391.6	376.62	*160	30	60	*170	30	100			
32	403.7	388.69	*160	30	60	*170	30	100	*170	40	150
33	415.8	400.81	*160	30	60	*170	30	100	*170	40	150
34	427.8	412.93	*160	30	60	*170	30	100	*170	40	150
35	440.0	425.04	*160	30	60	*170	30	100	*170	40	150
36	452.0	437.16	*160	30	60	*170	30	100	*170	40	150
37	464.2	449.27	*160	30	60	*170	30	100			
38	476.2	461.39	*160	30	60	*170	30	100	*170	40	150
39	488.5	473.50	*160	30	60	*170	30	100			
40	500.6	485.62	*160	30	60	*170	30	100	*170	40	150

P L A T E W H E E L S

1" 1/2 x 1"

for roller chains in compliance with
DIN 8187 ISO/R 606

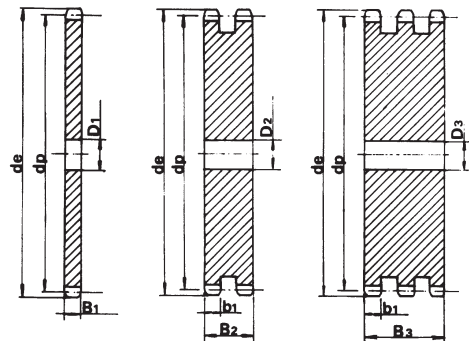
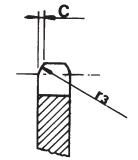

PLATEWHEEL mm

TOOTH RADIUS r_3	38
RADIUS WIDTH C	4
PLATE TOOTH WIDTH B_1	24.1
PLATE TOOTH WIDTH b_1	23.6
PLATE TOOTH WIDTH B_2	72
PLATE TOOTH WIDTH B_3	120.3

CHAIN mm

PITCH	38.1
INNER WIDTH	25.4
ROLLER - \emptyset	25.4

Z	d_e	d_p	S D T			Z	d_e	d_p	S D T		
			D_1	D_2	D_3				D_1	D_2	D_3
8	115.0	99.55	20	25	25	43	536.8	521.97	30		
9	126.4	111.40	20	25	25	44	549.0	534.08	30		
10	138.0	123.29	20	25	25	45	561.2	546.20	30	40	40
11	150.0	135.21	20	25	25	46	573.3	558.32	30	40	40
12	162.0	147.22	20	25	25	47	585.4	570.43	30		
13	174.2	159.18	20	25	25	48	597.4	582.55	30	40	40
14	186.2	171.22	20	25	25	49	609.5	594.66	30		
15	198.2	183.26	20	25	25	50	621.7	606.78	30	40	40
16	210.3	195.30	25	25	25	51	633.8	618.89	30		
17	222.3	207.34	25	25	25	52	646.0	631.01	30		
18	234.3	219.42	25	25	25	53	658.0	643.13	30		
19	246.5	231.49	25	25	25	54	670.2	655.28	30		
20	258.6	243.57	25	25	25	55	682.3	667.40	30	40	40
21	270.6	255.65	25	25	30	56	694.4	679.51	30		
22	282.7	267.73	25	25	30	57	706.5	691.63	30	40	40
23	294.8	279.80	25	25	30	58	718.6	703.74	30		
24	306.8	291.88	25	25	30	59	730.7	715.86	30		
25	319.0	304.00	25	25	30	60	742.8	727.97	30	40	40
26	331.0	316.08	30	30	30	62	767.2	752.24	40		
27	343.2	328.19	30	30	30	64	791.3	776.48	40		
28	355.2	340.27	30	30	30	65	803.4	788.59	40	40	40
29	367.3	352.38	30	30	30	66	815.6	800.71	40		
30	379.5	364.50	30	30	40	68	839.8	824.98	40		
31	391.6	376.62	30	30		70	864.2	849.21	40		
32	403.7	388.69	30	30	40	72	888.4	873.48	40		
33	415.8	400.81	30	30	40	75	924.8	909.83	40		
34	427.8	412.93	30	30	40	76	936.9	921.98	40	40	40
35	440.0	425.04	30	30	40	80	985.4	970.44	40		
36	452.0	437.16	30	30	40	85	1046.0	1031.10	40		
37	464.2	449.27	30	30		95	1167.3	1152.33	40		
38	476.2	461.39	30	30	40						
39	488.5	473.50	30	30							
40	500.6	485.62	30	30	40						
41	512.6	497.74	30								
42	524.7	509.85	30	40	40						

S P R O C K E T S

1" 3/4 x 1" 1/4

for roller chains in compliance with
DIN 8187 ISO/R 606

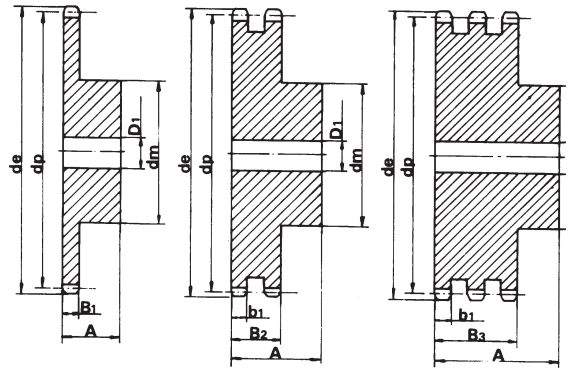
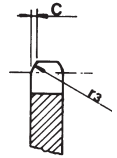

SPROCKET

	mm
TOOTH RADIUS r_3	44
RADIUS WIDTH C	5
SPROCKET TOOTH WIDTH B_1	29.4
SPROCKET TOOTH WIDTH b_1	28.8
SPROCKET TOOTH WIDTH B_2	88.4
SPROCKET TOOTH WIDTH B_3	148

CHAIN

	mm
PITCH	44.45
INNER WIDTH	30.99
ROLLER - \emptyset	27.94

MATERIAL: C 45 UNI 7845 *MATERIAL: FE - WITH WELDED HUB

Z	d_e	d_p	SINGLE			DOUBLE			TRIPLE		
			d_m	D_1	A	d_m	D_1	A	d_m	D_1	A
8	132.0	116.15	74	25	70	74	25	120	74	30	180
9	148.4	129.96	88	25	70	88	25	120	88	30	180
10	162.3	143.85	100	25	70	100	25	120	100	30	180
11	176.3	157.77	112	25	70	112	25	120	112	30	180
12	189.5	171.74	125	25	70	125	25	120	125	30	180
13	204.2	185.75	*130	25	70	*130	25	120	*130	30	180
14	218.2	199.76	*130	25	70	*130	25	120	*130	30	180
15	232.3	213.79	*145	25	70	*145	25	120	*145	30	180
16	246.3	227.84	*160	30	75	*160	30	120	*160	30	180
17	260.0	241.91	*160	30	75	*160	30	120	*160	30	180
18	274.0	255.98	*160	30	75	*160	30	120	*160	30	180
19	289.0	270.06	*160	30	75	*180	30	120	*180	30	180
20	303.0	284.15	*160	30	75	*180	30	120	*180	30	180
21	317.0	298.24	*170	30	75	*180	30	120	*180	30	180
22	331.0	312.34	*170	30	75	*180	30	120	*180	30	180
23	345.0	326.44	*170	30	75	*180	30	120	*180	30	180
24	359.0	340.55	*170	30	75	*180	30	120	*180	30	180
25	373.0	354.66	*170	30	75	*180	30	120	*180	40	180
26	387.0	368.77	*170	30	75	*180	30	120	*180	40	180
27	401.4	382.88	*170	30	75	*180	30	120	*180	40	180
28	416.0	397.00	*170	30	75	*180	30	120	*180	40	180
29	430.0	411.12	*170	30	75	*180	30	120	*180	40	180
30	444.0	425.24	*170	30	75	*180	30	120	*180	40	180
31	458.0	439.37	*180	30	75						
32	472.0	453.49	*180	30	75						
33	486.0	467.62	*180	30	75						
34	500.0	481.75	*180	30	75						
35	514.0	495.88	*180	30	75	*200	30	120	*200	40	180
36	529.0	510.01	*180	30	75						
37	543.0	524.14	*180	30	75						
38	557.0	538.27	*180	30	75	*200	30	120	*200	40	180
39	571.0	552.40	*180	30	75						
40	585.0	566.54	*180	30	75	*200	30	120	*200	40	180

P L A T E W H E E L S

1" 3/4 x 1" 1/4

for roller chains in compliance with
DIN 8187 ISO/R 606

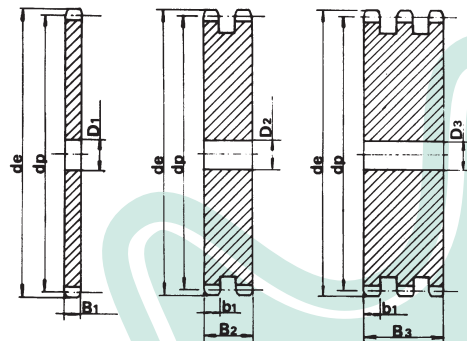
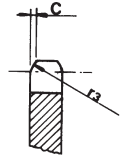

PLATEWHEEL

	mm
TOOTH RADIUS r_3	44
RADIUS WIDTH C	5
PLATE TOOTH WIDTH B_1	29.4
PLATE TOOTH WIDTH b_1	28.3
PLATE TOOTH WIDTH B_2	88.4
PLATE TOOTH WIDTH B_3	148

CHAIN

	mm
PITCH	44.45
INNER WIDTH	30.99
ROLLER - \emptyset	27.94

Z	d_e	d_p	S D T			Z	d_e	d_p	S D T		
			D_1	D_2	D_3				D_1	D_2	D_3
8	132.0	116.15	25	25	25	57	825.0	806.90	40	40	40
9	148.4	129.96	25	25	25	60	869.0	849.32	40	40	40
10	162.3	143.85	25	25	25	76	1095.0	1075.62	40	40	40
11	176.3	157.77	25	25	30						
12	189.5	171.74	25	25	30						
13	204.2	185.75	25	25	30						
14	218.2	199.76	25	25	30						
15	232.3	213.79	25	25	30						
16	246.3	227.84	30	30	30						
17	260.0	241.91	30	30	30						
18	274.0	255.98	30	30	30						
19	289.0	270.06	30	30	30						
20	303.0	284.15	30	30	30						
21	317.0	298.24	30	30	30						
22	331.0	312.34	30	30	30						
23	345.0	326.44	30	30	30						
24	359.0	340.55	30	30	30						
25	373.0	354.66	30	30	40						
26	387.0	368.77	30	30	40						
27	401.4	382.88	30	30	40						
28	416.0	397.00	30	30	40						
29	430.0	411.12	30	30	40						
30	444.0	425.24	30	30	40						
31	458.0	439.37	30								
32	472.0	453.49	30								
33	486.0	467.62	30								
34	500.0	481.75	30								
35	514.0	495.88	30	30	40						
36	529.0	510.01	30								
37	543.0	524.14	30								
38	557.0	538.27	30	30	40						
39	571.0	552.40	30								
40	585.0	566.54	30	30	40						
45	656.0	637.22	30	30	40						
50	726.0	707.91	30	30	40						

S P R O C K E T S

2" x 1" 1/4

for roller chains in compliance with
DIN 8187 ISO/R 606

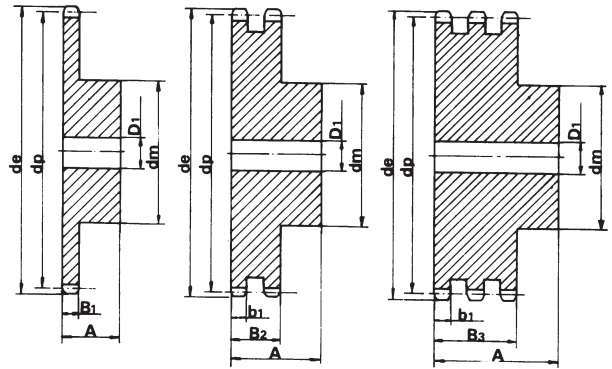
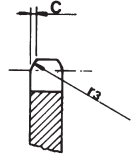

SPROCKET

	mm
TOOTH RADIUS r_3	51
RADIUS WIDTH C	5
SPROCKET TOOTH WIDTH B_1	29.4
SPROCKET TOOTH WIDTH b_1	28.8
SPROCKET TOOTH WIDTH B_2	87.4
SPROCKET TOOTH WIDTH B_3	146

CHAIN

	mm
PITCH	50.8
INNER WIDTH	30.99
ROLLER - \varnothing	29.21

MATERIAL: C 45 UNI 7845 *MATERIAL: FE - WITH WELDED HUB

Z	d_e	d_p	SINGLE			DOUBLE			TRIPLE		
			d_m	D_1	A	d_m	D_1	A	d_m	D_1	A
8	153.2	132.69	82	25	80	82	30	120	82	30	180
9	169.0	148.54	88	25	80	88	30	120	88	30	180
10	185.0	164.44	104	25	80	104	30	120	104	30	180
11	200.8	180.34	120	30	80	120	30	120	120	30	180
12	216.8	196.29	*133	30	80	*133	30	120	*133	30	180
13	232.8	212.29	*145	30	80	*145	30	120	*145	30	180
14	248.8	228.29	*160	30	80	*160	30	120	*160	30	180
15	264.8	244.30	*160	30	80	*160	30	120	*160	30	180
16	280.9	260.40	*160	30	90	*160	30	120	*160	30	180
17	296.9	276.40	*170	30	90	*180	30	120	*180	30	180
18	313.0	292.55	*170	30	90	*180	30	120	*180	30	180
19	329.1	308.66	*170	30	90	*200	30	120	*200	30	180
20	345.2	324.71	*180	30	90	*200	30	120	*200	30	180
21	361.3	340.82	*180	30	90	*200	30	120	*200	40	180
22	377.5	356.98	*180	30	90	*200	30	120	*200	40	180
23	393.6	373.08	*180	30	90	*200	30	120	*200	40	180
24	409.7	389.18	*180	30	90	*200	30	120	*200	40	180
25	425.8	405.33	*180	30	90	*200	30	120	*200	40	180
26	441.9	421.44	*180	30	90	*200	30	120	*200	40	180
27	458.1	437.59	*180	30	90	*200	30	120	*200	40	180
28	474.2	453.69	*180	30	90	*200	30	120	*200	40	180
29	490.4	469.90	*180	30	90						
30	506.5	486.00	*180	30	90	*200	30	120	*200	40	180
32	538.8	518.28	*180	30	90						
35	589.5	566.72	*180	30	90						
38	635.5	615.14	*180	30	90						
40	670.3	647.49	*180	30	90						

P L A T E W H E E L S

2" x 1" 1/4

for roller chains in compliance with
DIN 8187 ISO/R 606

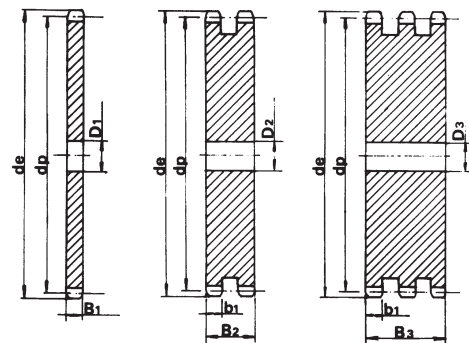
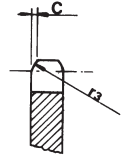

PLATEWHEEL

	mm
TOOTH RADIUS r_3	51
RADIUS WIDTH C	5
PLATE TOOTH WIDTH B_1	29.4
PLATE TOOTH WIDTH b_1	28.8
PLATE TOOTH WIDTH B_2	87.4
PLATE TOOTH WIDTH B_3	146

CHAIN

	mm
PITCH	50.8
INNER WIDTH	30.99
ROLLER - \varnothing	29.21

Z	d_e	d_p	S D T			Z	d_e	d_p	S D T		
			D_1	D_2	D_3				D_1	D_2	D_3
8	153.2	132.69	25	25	25	76	1252.0	1229.28	40	40	40
9	169.0	148.54	25	25	25						
10	185.0	164.44	25	25	25						
11	200.8	180.34	30	30	30						
12	216.8	196.29	30	30	30						
13	232.8	212.29	30	30	30						
14	248.8	228.29	30	30	30						
15	264.8	244.30	30	30	30						
16	280.9	260.40	30	30	30						
17	296.9	276.40	30	30	30						
18	313.0	292.55	30	30	30						
19	329.1	308.66	30	30	30						
20	345.2	324.71	30	30	30						
21	361.3	340.82	30	30	40						
22	377.5	356.98	30	30	40						
23	393.6	373.08	30	30	40						
24	409.7	389.18	30	30	40						
25	425.8	405.33	30	30	40						
26	441.9	421.44	30	30	40						
27	458.1	437.59	30	30	40						
28	474.2	453.69	30	30	40						
29	490.4	469.90	30								
30	506.5	486.00	30	30	40						
32	538.8	518.26	30								
35	589.5	566.72	30	30	40						
38	635.5	615.14	30	30	40						
40	670.3	647.49	40	40	40						
45	751.0	728.26	40	40	40						
50	831.8	809.04	40	40	40						
57	945.0	922.17	40	40	40						
60	993.4	970.63	40	40	40						

Taper - Lock® SPROCKETS

PITCH

SIMPLE						
Pitch code	Z	bush	Type of Execution	Hub Dm	A	
081-13	13	1610	1	78	25	
081-14	14	1610	1	78	25	
081-15 •	15	1610	1	78	25	
081-16	16	2012	1	90	32	
081-17 •	17	2012	1	90	32	
081-18	18	2517	1	108	45	
081-19 •	19	2517	1	108	45	
081-20	20	2517	1	108	45	
081-21 •	21	2517	1	108	45	
081-22	22	2517	1	108	45	
081-23 •	23	2517	1	108	45	
081-24	24	2517	1	108	45	
081-25 •	25	2517	1	108	45	
081-26	26	2517	1	108	45	
081-27 •	27	2517	1	108	45	
081-28	28	2517	1	108	45	
081-30 •	30	3020	1	159	51	
081-38	38	3020	6	159	51	
081-45	45	3020	6	159	51	
081-57*	57	3020	6	159	51	
081-76*	76	3020	6	159	51	
081-95*	95	3020	6	159	51	
081-114*	114	3030	6	150	76	
101-15 •	15	2517	1	108	45	
101-17 •	17	2517	1	108	45	
101-19 •	19	2517	1	108	45	
101-21 •	21	2517	1	108	45	
101-23 •	23	2517	1	108	45	
101-25 •	25	2517	1	108	45	
101-30	30	3020	1	159	51	
101-38	38	3020	1	159	55	

1"
25.40 mm

1" 1/4
31.75 mm

PITCH

DOUBLE						
Pitch code	Z	bush	Type of Execution	Hub Dm	A	
082-15	15	2012	3		47.7	
082-16	16	2517	3		47.7	
082-17	17	2517	3		47.7	
082-18	18	2517	3		47.7	
082-19	19	2517	3		47.7	
082-20	20	2517	3		47.7	
082-21	21	3020	2	143	51	
082-22	22	3020	2	150	51	
082-23	23	3020	2	159	51	
082-24	24	3020	2	166	51	
082-25	25	3020	2	175	51	
082-26	26	3020	2	175	51	
082-27	27	3020	2	175	51	
082-28	28	3020	2	175	51	
082-30	30	3020	2	175	51	
082-38*	38	3020	7	146	51	
082-45*	45	3020	7	146	51	
082-57*	57	3525	7	198	65	
082-76*	76	3525	7	198	65	
082-95*	95	3525	7	216	65	
082-114*	114	4040	7	216	102	

1"
25.40 mm

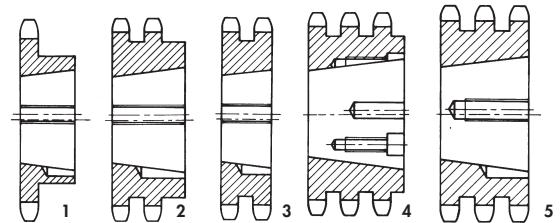

PITCH

TRIPLE						
Pitch code	Z	bush	Type of Execution	Hub Dm	A	
063-15	15	1615	5		49.8	
063-17	17	2012	5		49.8	
063-19	19	2012	5		49.8	
063-21	21	2517	5		49.8	
063-23	23	2517	5		49.8	
063-25	25	2517	5		49.8	
063-27	27	3020	5		51.0	
063-30	30	3020	5		51.0	
063-38	38	3020	5		51.0	
063-45	45	3020	5		51.0	
063-57*	57	3020	8	159	51.0	
063-76*	76	3020	8	159	51.0	
063-95*	95	3030	8	165	76.0	
063-114*	114	3030	8	165	76.0	
083-17	17	2517	5		79.6	
083-19	19	3020	5		79.6	
083-21	21	3020	5		79.6	
083-23	23	3525	5		79.6	
083-25	25	3525	5		79.6	
083-27	27	3525	5		79.6	
083-30	30	3525	5		79.6	
083-38	38	3525	5		79.6	
083-45*	45	4030	9	216	79.6	
083-57*	57	4030	9	216	79.6	
083-76*	76	4030	9	216	79.6	
083-95*	95	4030	9	240	79.6	
083-114*	114	4545	8	240	115	

3/4"
19.05 mm

1"
25.40 mm

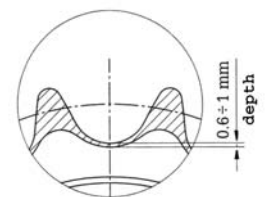
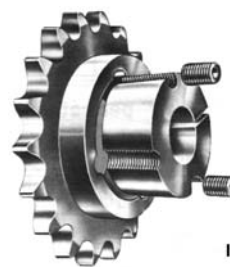
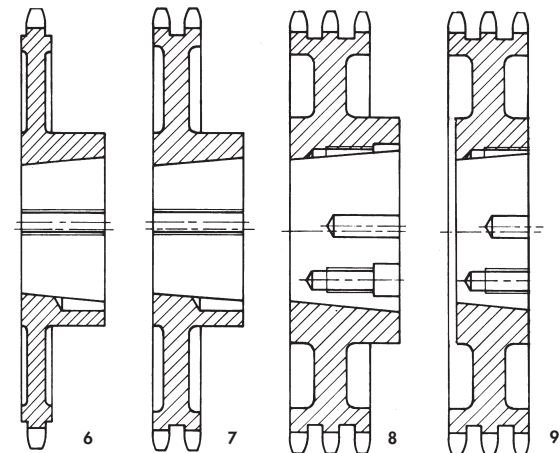

Induction hardened teeth HRC 45±3

• ALSO AVAILABLE WITH HARDENED TEETH

MATERIAL: STEEL = C 45 UNI 7845 * CAST IRON = G 20 - UNI 5007